

# MACHOS TERRAJAS

**JUEGOS DE MACHOS Y TERRAJAS PARA ROSCAR A MANO HSS**

Machos y Terrajas

Verde

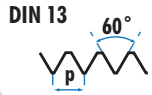

Ref. M0

HSS

DIN 352

DIN 2181

TOL 6H

Ref. C5

HSS

DIN 223

TOL 6g

Para materiales hasta 38 HRC



		M0				C5				M0		C5	
	Uds.		L1 x L2 x $\nabla$ mm	€	Ø x L3 mm	€		Uds.		L1 x L2 x $\nabla$ mm	€	Ø x L3 mm	€
M 1x0,20	2	0,80	32 x 5,5 x 2,1	86,39			M 5,5x0,90	3	4,60	50 x 16 x 4,9	87,65	25 x 9	98,71
<b>M 1x0,25</b>	<b>3</b>	<b>0,75</b>	32 x 6,0 x 2,1	86,39	16 x 5	89,82	M 6x0,50	2	5,50	50 x 14 x 4,9	29,76	20 x 5	38,19
M 1,1x0,20	2	0,90	32 x 5,5 x 2,1	86,39			M 6x0,75	2	5,25	50 x 14 x 4,9	25,12	25 x 9	31,32
M 1,1x0,25	3	0,85	32 x 6,0 x 2,1	86,39	16 x 5	88,84	<b>M 6x1,00</b>	<b>3</b>	<b>5,00</b>	50 x 19 x 4,9	22,46*	25 x 9	27,87*
M 1,2x0,20	2	1,00	32 x 5,5 x 2,1	86,39			M 6x1,25	3	4,75	50 x 19 x 4,9	143,81	25 x 9	101,07
M 1,2x0,25	3	0,95	32 x 6,0 x 2,1	86,39	16 x 5	83,36	M 7x0,75	2	6,25	50 x 14 x 4,9	32,98	25 x 9	31,01
M 1,4x0,20	2	1,20	32 x 7,0 x 2,1	86,39			<b>M 7x1,00</b>	<b>3</b>	<b>6,00</b>	50 x 19 x 4,9	27,10*	25 x 9	29,25*
M 1,4x0,25	2	1,15	32 x 7,0 x 2,1	86,39			M 7x1,25	3	5,75	50 x 19 x 4,9	99,92	25 x 9	121,47
M 1,4x0,30	3	1,10	32 x 7,0 x 2,1	86,39	16 x 5	78,56	M 8x0,50	2	7,50	50 x 16 x 4,9	52,50	25 x 9	46,30
M 1,6x0,20	2	1,40	32 x 8,0 x 2,1	78,82			M 8x0,75	2	7,25	50 x 16 x 4,9	34,56	25 x 9	33,53
M 1,6x0,25	2	1,35	32 x 8,0 x 2,1	78,82			M 8x1,00	2	7,00	56 x 18 x 4,9	25,00*	25 x 9	32,33*
M 1,6x0,35	3	1,25	32 x 8,0 x 2,1	78,82	16 x 5	74,22	<b>M 8x1,25</b>	<b>3</b>	<b>6,80</b>	56 x 22 x 4,9	27,08*	25 x 9	29,57*
M 1,7x0,35	3	1,35	32 x 8,0 x 2,1	73,98	16 x 5	74,22	M 8x1,50	3	6,50	56 x 22 x 4,9	97,19	25 x 9	105,60
M 1,8x0,20	2	1,60	32 x 8,0 x 2,1	73,98			M 9x1,00	2	8,00	63 x 18 x 5,5	36,61	25 x 9	35,93
M 1,8x0,25	2	1,55	32 x 8,0 x 2,1	73,98			<b>M 9x1,25</b>	<b>3</b>	<b>7,80</b>	63 x 22 x 5,5	44,36*	25 x 9	34,37*
M 1,8x0,35	3	1,45	32 x 8,0 x 2,1	73,98	16 x 5	74,22	M 10x0,50	2	9,50	63 x 18 x 5,5	54,13	30 x 10	116,69
M 2x0,25	2	1,75	36 x 8,0 x 2,1	73,98			M 10x0,75	2	9,25	63 x 18 x 5,5	55,35	30 x 11	57,37
M 2x0,35	2	1,65	36 x 8,0 x 2,1	73,98			M 10x1,00	2	9,00	63 x 18 x 5,5	26,77	38 x 10	38,04
<b>M 2x0,40</b>	<b>3</b>	<b>1,60</b>	36 x 9,0 x 2,1	37,10*	16 x 5	30,64*	M 10x1,25	2	8,80	70 x 24 x 5,5	27,14	38 x 10	40,58
M 2,2x0,45	3	1,75	36 x 9,0 x 2,1	42,13	20 x 5	65,52	<b>M 10x1,50</b>	<b>3</b>	<b>8,50</b>	70 x 24 x 5,5	33,39*	38 x 10	39,58*
M 2,3x0,40	3	1,90	36 x 9,0 x 2,1	38,88	20 x 5	33,60	M 11x0,75	2	10,25	63 x 18 x 6,2	81,27	30 x 11	126,07
M 2,5x0,45	3	2,05	40 x 9,0 x 2,1	36,97	20 x 5	30,64	M 11x1,00	2	10,00	63 x 18 x 6,2	51,20	30 x 11	60,04
M 2,6x0,45	3	2,10	40 x 9,0 x 2,1	37,79	25 x 9	32,08	M 11x1,25	2	9,75	63 x 20 x 6,2	51,20	30 x 11	60,03
M 3x0,35	2	2,65	40 x 9,0 x 2,7	48,31	20 x 5	48,52	<b>M 11x1,50</b>	<b>3</b>	<b>9,50</b>	70 x 24 x 6,2	55,65	38 x 10	47,95
<b>M 3x0,50</b>	<b>3</b>	<b>2,50</b>	40 x 11,0 x 2,7	20,83*	25 x 9	27,87*	M 12x0,75	2	11,25	70 x 20 x 7,0	73,90	38 x 10	65,09
M 3x0,60	3	2,40	45 x 13,0 x 3,0	42,36	20 x 5	38,02	M 12x1,00	2	11,00	70 x 20 x 7,0	47,47	38 x 10	57,37
M 3,5x0,60	3	2,90	45 x 13,0 x 3,0	24,84	25 x 9	29,16	M 12x1,25	2	10,75	70 x 20 x 7,0	47,33	38 x 10	55,31
M 3,5x0,75	3	2,75	45 x 18,0 x 3,0	46,00	25 x 9	65,57	M 12x1,50	2	10,50	70 x 20 x 7,0	40,33*	38 x 10	49,60*
M 4x0,50	2	3,50	45 x 13,0 x 3,4	42,16	25 x 9	31,31	<b>M 12x1,75</b>	<b>3</b>	<b>10,20</b>	75 x 29 x 7,0	47,42*	38 x 14	43,00*
<b>M 4x0,70</b>	<b>3</b>	<b>3,30</b>	45 x 13,0 x 3,4	20,81*	25 x 9	28,01*	M 13x0,75	2	12,25	70 x 20 x 9,0	83,51	38 x 10	114,77
M 4x0,75	3	3,25	45 x 13,0 x 3,4	34,45	20 x 7	42,36	M 13x1,00	2	12,00	70 x 20 x 9,0	80,40	38 x 10	60,95
M 4x0,80	3	3,20	45 x 13,0 x 3,4	83,01	20 x 7	100,13	M 13x1,25	2	11,75	70 x 20 x 9,0	73,40	38 x 10	81,50
M 4,5x0,50	2	4,00	50 x 12,0 x 4,9	40,52	25 x 9	43,61	M 13x1,50	2	11,50	70 x 20 x 9,0	73,40	38 x 10	64,07
M 4,5x0,75	3	3,75	50 x 16,0 x 4,9	37,10	20 x 7	30,65	<b>M 13x1,75</b>	<b>3</b>	<b>11,25</b>	70 x 20 x 9,0	84,92	38 x 14	68,65
M 5x0,50	2	4,50	50 x 12,0 x 4,9	41,58	20 x 5	34,19	M 14x0,75	2	13,25	70 x 20 x 9,0	95,97	38 x 10	107,61
M 5x0,75	2	4,25	50 x 14,0 x 4,9	41,28	20 x 7	42,58	M 14x1,00	2	13,00	70 x 20 x 9,0	73,99	38 x 10	64,34
<b>M 5x0,80</b>	<b>3</b>	<b>4,20</b>	50 x 16,0 x 4,9	22,46*	25 x 9	27,85*	M 14x1,25	2	12,80	70 x 20 x 9,0	57,79*	38 x 10	64,34*
M 5x0,90	3	4,10	50 x 16,0 x 4,9	39,34	25 x 9	42,58	M 14x1,50	2	12,50	70 x 20 x 9,0	44,94	38 x 10	54,77
M 5x1,00	3	4,00	50 x 16,0 x 4,9	87,65	25 x 9	96,54	M 14x1,75	2	12,25	70 x 20 x 9,0	89,88	38 x 14	183,25
							<b>M 14x2,00</b>	<b>3</b>	<b>12,00</b>	80 x 30 x 9,0	52,46*	38 x 14	42,58*
							M 15x1,00	2	14,00	70 x 20 x 9,0	103,66	45 x 14	69,28
							M 15x1,25	2	13,75	70 x 20 x 9,0	107,41	45 x 14	107,33
							M 15x1,50	2	13,50	70 x 20 x 9,0	96,16	45 x 14	74,23
							<b>M 15x2,00</b>	<b>3</b>	<b>13,00</b>	80 x 30 x 9,0	103,90	45 x 14	93,04
							M 16x1,00	2	15,00	70 x 20 x 9,0	98,15	45 x 14	78,44
							M 16x1,25	2	14,75	70 x 20 x 9,0	103,31	45 x 14	66,00
							M 16x1,50	2	14,50	70 x 20 x 9,0	55,92*	45 x 14	61,61*
							<b>M 16x2,00</b>	<b>3</b>	<b>14,00</b>	80 x 32 x 9,0	75,78*	45 x 18	57,73*
							M 17x1,00	2	16,00	70 x 20 x 9,0	158,52	45 x 14	112,25
							M 17x1,25	2	15,75	70 x 20 x 9,0	158,52	45 x 14	112,25
							M 17x1,50	2	15,50	70 x 20 x 9,0	158,52	45 x 14	112,25
							M 18x1,00	2	17,00	80 x 22 x 11,0	109,12	45 x 14	82,94
							M 18x1,25	2	16,75	80 x 22 x 11,0	155,77	45 x 14	86,27

\* Disponibles también con rosca izquierda con 100% de recargo sobre los precios tarifados en rosca derecha  
 \* Recargo por cojinetes abiertos 20% sobre los precios tarifados

JUEGOS DE MACHOS Y TERRAJAS PARA ROSCAR A MANO HSS

MF

DIN 13 60°

Ref. M0

HSS

DIN 352

DIN 2181

TOL 6H

Ref. C5

HSS

DIN 223

TOL 6g

		M0					C5						
	Uds.		L1 x L2 x mm	€	Ø x L3 mm	€		Uds.		L1 x L2 x mm	€	Ø x L3 mm	€
M 18x1,50	2	16,50	80 x 22 x 11,0	73,68	45 x 14	74,62	M 33x3,50	3	29,5	125 x 50 x 20,0	357,28*	65 x 25	132,40*
M 18x2,00	2	16,00	80 x 22 x 11,0	117,60*	45 x 14	83,38*	M 34x1,50	2	32,5	100 x 25 x 22,0	367,14	65 x 18	151,53
<b>M 18x2,50</b>	<b>3</b>	<b>15,50</b>	<b>95 x 40 x 11,0</b>	<b>100,01*</b>	<b>45 x 18</b>	<b>57,75*</b>	M 34x2,00	2	32,0	100 x 25 x 22,0	439,08	65 x 18	345,88
M 19x1,00	2	18,00	80 x 22 x 11,0	230,06	45 x 14	139,23	M 35x1,50	2	33,5	100 x 25 x 22,0	391,98	65 x 18	157,17
M 19x1,25	2	17,75	80 x 22 x 11,0	230,06	45 x 14	157,46	M 35x2,00	2	33,0	100 x 25 x 22,0	439,08	65 x 18	269,72
M 19x1,50	2	17,50	80 x 22 x 11,0	230,06	45 x 14	139,23	M 36x1,50	2	34,5	100 x 25 x 22,0	382,70	65 x 18	148,78
M 19x2,00	2	17,00	80 x 22 x 11,0	273,10	45 x 14	159,06	M 36x2,00	2	34,0	125 x 33 x 22,0	504,06	65 x 18	155,18
M 20x1,00	2	19,00	80 x 22 x 12,0	148,56	45 x 14	82,94	M 36x3,00	2	33,0	125 x 33 x 22,0	665,73*	65 x 25	155,69*
M 20x1,25	2	18,75	80 x 22 x 12,0	229,22	45 x 14	180,02	<b>M 36x4,00</b>	<b>3</b>	<b>32,0</b>	150 x 53 x 22,0	459,98*	65 x 25	134,98*
M 20x1,50	2	18,50	80 x 22 x 12,0	92,27	45 x 14	76,35	M 38x1,50	2	36,5	100 x 25 x 22,0	442,32	75 x 20	227,33
M 20x2,00	2	18,00	80 x 22 x 12,0	124,57*	45 x 14	82,94*	M 38x2,00	2	36,0	125 x 25 x 22,0	595,32	75 x 20	335,91
<b>M 20x2,50</b>	<b>3</b>	<b>17,50</b>	<b>95 x 40 x 12,0</b>	<b>112,19*</b>	<b>45 x 18</b>	<b>56,85*</b>	M 39x1,50	2	37,5	110 x 25 x 24,0	585,44	75 x 20	226,12
M 21x1,00	2	20,00	80 x 22 x 12,0	294,75	45 x 14	170,57	M 39x2,00	2	37,0	125 x 23 x 24,0	585,44	75 x 20	238,79
M 21x1,25	2	19,75	80 x 22 x 12,0	294,75	45 x 14	170,57	M 39x3,00	2	36,0	125 x 33 x 24,0	564,72*	75 x 30	243,90*
M 21x1,50	2	19,50	80 x 22 x 12,0	229,45	45 x 14	180,30	<b>M 39x4,00</b>	<b>3</b>	<b>35,0</b>	150 x 53 x 24,0	519,59*	75 x 30	205,31*
M 22x1,00	2	21,00	80 x 22 x 14,5	166,49	55 x 16	111,65	M 40x1,50	2	38,5	110 x 25 x 24,0	519,43	75 x 20	237,53
M 22x1,25	2	20,75	80 x 22 x 14,5	227,01	55 x 16	181,95	M 40x2,00	2	38,0	125 x 33 x 24,0	572,00	75 x 20	220,57
M 22x1,50	2	20,50	80 x 22 x 14,5	101,48	55 x 16	96,05	M 40x3,00	2	37,0	125 x 33 x 24,0	569,91	75 x 30	240,56
M 22x2,00	2	20,00	80 x 22 x 14,5	161,88*	55 x 16	106,87*	M 42x1,50	2	40,5	110 x 25 x 24,0	564,61	75 x 20	264,10
<b>M 22x2,50</b>	<b>3</b>	<b>19,50</b>	<b>100 x 40 x 14,5</b>	<b>146,62*</b>	<b>55 x 22</b>	<b>85,42*</b>	M 42x2,00	2	40,0	125 x 33 x 24,0	669,31	75 x 20	279,26
M 23x1,00	2	22,00	80 x 22 x 14,5	297,32	55 x 16	184,50	M 42x3,00	2	39,0	125 x 33 x 24,0	672,19	75 x 30	264,10
M 23x1,50	2	21,50	80 x 22 x 14,5	296,16	55 x 16	218,74	<b>M 42x4,50</b>	<b>3</b>	<b>37,5</b>	150 x 53 x 24,0	643,97	75 x 30	205,29
M 24x1,00	2	23,00	90 x 22 x 14,5	179,64	55 x 16	108,90	M 45x1,50	2	43,5	110 x 25 x 29,0	616,71	90 x 22	308,61
M 24x1,25	2	22,75	90 x 22 x 14,5	293,60	55 x 16	144,58	M 45x2,00	2	43,0	125 x 33 x 29,0	803,80	90 x 22	335,03
M 24x1,50	2	22,50	90 x 22 x 14,5	129,37	55 x 16	97,86	M 45x3,00	2	42,0	125 x 33 x 29,0	803,80	90 x 36	349,56
M 24x2,00	2	22,00	90 x 22 x 14,5	193,03*	55 x 16	108,90*	<b>M 45x4,50</b>	<b>3</b>	<b>40,5</b>	160 x 60 x 29,0	743,42	90 x 36	318,11
<b>M 24x3,00</b>	<b>3</b>	<b>21,00</b>	<b>110 x 50 x 14,5</b>	<b>178,25*</b>	<b>55 x 22</b>	<b>85,42*</b>	M 48x1,50	2	46,5	140 x 33 x 29,0	688,52	90 x 22	301,58
M 25x1,00	2	24,00	90 x 22 x 14,5	253,42	55 x 16	165,26	M 48x2,00	2	46,0	140 x 33 x 29,0	1.050,51	90 x 22	330,33
M 25x1,25	2	23,75	90 x 22 x 14,5	331,90	55 x 16	217,60	M 48x3,00	2	45,0	140 x 33 x 29,0	974,05	90 x 36	318,67
M 25x1,50	2	23,50	90 x 22 x 14,5	239,09	55 x 16	142,16	<b>M 48x5,00</b>	<b>3</b>	<b>43,0</b>	180 x 65 x 29,0	895,08	90 x 36	318,49
M 25x2,00	2	23,00	90 x 22 x 14,5	432,21	55 x 16	211,57	M 50x1,50	2	48,5	140 x 33 x 29,0	752,98	90 x 22	314,46
M 26x1,00	2	25,00	90 x 22 x 14,5	226,54	55 x 16	163,80	M 50x3,00	2	57,0	140 x 33 x 29,0	1.005,56	90 x 22	342,72
M 26x1,50	2	24,50	90 x 22 x 14,5	212,55	55 x 16	132,06	M 52x1,50	2	50,5	140 x 33 x 32,0	789,84	90 x 22	321,11
M 26x2,00	2	24,00	90 x 22 x 14,5	249,39	55 x 16	185,10	M 52x2,00	2	50,0	140 x 33 x 32,0	1.145,99	90 x 22	373,18
M 27x1,00	2	26,00	90 x 22 x 16,0	249,41	65 x 18	147,35	M 52x3,00	2	49,0	140 x 33 x 32,0	1.055,09	90 x 36	407,24
M 27x1,50	2	25,50	90 x 22 x 16,0	240,81	65 x 18	147,98	<b>M 52x5,00</b>	<b>3</b>	<b>47,0</b>	180 x 65 x 32,0	1.072,04	90 x 36	318,49
M 27x2,00	2	25,00	90 x 22 x 16,0	267,52*	65 x 18	160,94*	<b>M 56x4,00</b>	<b>2</b>	<b>52,0</b>	180 x 47 x 32,0	1.176,50	105 x 36	
<b>M 27x3,00</b>	<b>3</b>	<b>24,00</b>	<b>110 x 50 x 16,0</b>	<b>221,15*</b>	<b>65 x 25</b>	<b>129,58*</b>	<b>M 56x5,50</b>	<b>3</b>	<b>50,5</b>	200 x 85 x 35,0	1.663,92	105 x 36	
M 28x1,00	2	27,00	90 x 22 x 16,0	420,94	65 x 18	190,47	<b>M 60x5,50</b>	<b>3</b>	<b>54,5</b>	200 x 85 x 35,0	1.729,15	105 x 36	
M 28x1,50	2	26,50	90 x 22 x 16,0	236,11	65 x 18	134,15	<b>M 64x4,00</b>	<b>2</b>	<b>60,0</b>	180 x 50 x 35,0	1.656,92	120 x 36	
M 28x2,00	2	26,00	90 x 22 x 16,0	282,50	65 x 18	188,61	<b>M 64x6,00</b>	<b>3</b>	<b>58,0</b>	220 x 90 x 39,0	2.046,02	120 x 36	
M 30x1,00	2	29,00	90 x 22 x 18,0	262,20	65 x 18	156,15	<b>M 68x6,00</b>	<b>3</b>	<b>62,0</b>	220 x 90 x 39,0	2.449,47	120 x 36	
M 30x1,50	2	28,50	90 x 22 x 18,0	251,63	65 x 18	147,97	<b>M 72x6,00</b>	<b>3</b>	<b>66,0</b>	235 x 90 x 39,0	2.653,73	120 x 36	
M 30x2,00	2	28,00	90 x 22 x 18,0	290,10	65 x 18	163,99	<b>COJINETES CON MEDIDA EXTERIOR EN PULGADAS</b>						
M 30x3,00	2	27,00	125 x 56 x 18,0	283,60*	65 x 25	182,67*						C5	
<b>M 30x3,50</b>	<b>3</b>	<b>26,50</b>	<b>125 x 50 x 18,0</b>	<b>287,24*</b>	<b>65 x 25</b>	<b>129,91*</b>						€	
M 32x1,00	2	31,00	90 x 22 x 18,0	345,77	65 x 18	201,69			Ø x L3 mm	€			
M 32x1,50	2	30,50	90 x 22 x 18,0	299,61	65 x 18	153,47			mm				
M 32x2,00	2	30,00	90 x 22 x 18,0	428,86	65 x 18	186,92	<b>M 3x0,50</b>	<b>25,4 x 9</b>	<b>23,89</b>	<b>M 8x1,25</b>	<b>38,1 x 9</b>	<b>25,36</b>	
M 33x1,00	2	32,00	100 x 25 x 20,0	551,81	65 x 18	213,56	<b>M 4x0,70</b>	<b>25,4 x 9</b>	<b>23,89</b>	<b>M10x1,50</b>	<b>25,4 x 9</b>	<b>32,09</b>	
M 33x1,50	2	31,50	100 x 25 x 20,0	320,44	65 x 18	145,22	<b>M 5x0,80</b>	<b>25,4 x 9</b>	<b>24,34</b>	<b>M10x1,50</b>	<b>38,1 x 10</b>	<b>32,09</b>	
M 33x2,00	2	31,00	100 x 25 x 20,0	404,57	65 x 18	146,22	<b>M 6x1,00</b>	<b>25,4 x 9</b>	<b>23,89</b>	<b>M12x1,75</b>	<b>25,4 x 9</b>	<b>38,67</b>	
M 33x3,00	2	30,00	125 x 56 x 20,0	510,49*	65 x 25	225,64*	<b>M 8x1,25</b>	<b>25,4 x 9</b>	<b>25,36</b>	<b>M12x1,75</b>	<b>38,1 x 14</b>	<b>38,67</b>	

\* Disponibles también con rosca izquierda con 100% de recargo sobre los precios tarifados en rosca derecha  
 \* Recargo por cojinetes abiertos 20% sobre los precios tarifados



**JUEGOS DE MACHOS Y TERRAJAS PARA ROSCAR A MANO HSS**

UNC

Ref. M0

Ref. C5

**HSS**  
**DIN 351**  
**TOL 2B**

**HSS**  
**DIN 223**  
**TOL 2a**

UNF

Ref. M0

Ref. C5

**HSS**  
**DIN 2181**  
**TOL 2B**

**HSS**  
**DIN 223**  
**TOL 2a**

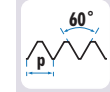

UNC	Uds.	D1 mm	L1 x L2 x mm	M0		C5	
				€	Ø x L3 mm	€	
UNC n°1-64h.	3	1,85	1,50	36x8x2,1	104,18	16x5	
UNC n°2-56h.	3	2,18	1,80	36x9x2,1	73,62	16x5	
UNC n°3-48h.	3	2,51	2,10	40x9x2,1	73,62	16x5	
UNC n°4-40h.	3	2,84	2,25	40x11x2,7	55,75	20x5	41,37
UNC n°5-40h.	3	3,17	2,60	40x11x2,7	53,30	20x5	41,48
UNC n°6-32h.	3	3,50	2,75	45x13x3,0	53,30	20x7	41,48
UNC n°8-32h.	3	4,17	3,50	45x13x3,4	53,30	20x7	41,48
UNC n°10-24h.	3	4,83	3,90	50x16x4,9	53,30	20x7	41,48
UNC n°12-24h.	3	5,49	4,50	50x19x4,9	53,30	20x7	41,48
UNC 1/4-20h.	3	6,35	5,10	50x19x4,9	45,68*	20x7	39,09*
UNC 5/16-18h.	3	7,94	6,60	56x22x4,9	51,86*	25x9	40,11*
UNC 3/8-16h.	3	9,52	8,00	70x24x5,5	59,00*	30x11	55,77*
UNC 7/16-14h.	3	11,11	9,40	70x24x6,2	76,83	38x14	55,77
UNC 1/2-13h.	3	12,70	10,75	75x29x7,0	88,40*	38x14	57,33*
UNC 9/16-12h.	3	14,28	12,20	80x30x9,0	104,36	38x14	60,00
UNC 5/8-11h.	3	15,87	13,50	80x32x9,0	143,92*	45x18	81,33*
UNC 3/4-10h.	3	19,05	16,50	95x40x11,0	196,10*	45x18	81,33*
UNC 7/8-9h.	3	22,22	19,50	100x40x14,5	241,41	55x22	113,55
UNC 1"-8h.	3	25,40	22,25	110x50x14,5	325,98*	55x22	109,17*
UNC 1.1/8-7h.	3	28,57	25,00	125x56x18,0	491,50	65x25	162,17
UNC 1.1/4-7h.	3	31,75	28,00	125x56x18,0	618,65	65x25	162,17
UNC 1.3/8-6h.	3	34,92	30,75	150x63x22,0	784,83	65x25	162,17
UNC 1.1/2-6h.	3	38,10	34,00	150x63x24,0	963,61	75x30	252,85
UNC 2"-4,5h.	3	50,80	45,00	180x75x32,0	2.075,55	90x36	

UNF	Uds.	D1 mm	L1 x L2 x mm	M0		C5	
				€	Ø x L3 mm	€	
UNF n°2-64h.	2	2,18	1,85	36x8x2,1	66,71		
UNF n°3-56h.	2	2,51	2,15	40x9x2,1	66,71		
UNF n°4-48h.	2	2,84	2,35	40x9x2,7	41,57	20x5	42,99
UNF n°5-44h.	2	3,17	2,70	45x10x2,7	41,57	20x5	41,48
UNF n°6-40h.	2	3,50	2,95	45x16x3,0	39,73	20x5	41,48
UNF n°8-36h.	2	4,17	3,50	50x12x3,4	39,73	20x7	41,48
UNF n°10-32h.	2	4,83	4,10	50x12x4,9	39,73	20x7	41,48
UNF n°12-28h.	2	5,49	4,60	50x12x4,9	41,57	20x7	41,48
UNF 1/4-28h.	2	6,35	5,50	50x14x4,9	30,32*	25x9	36,62*
UNF 5/16-24h.	2	7,94	6,90	56x22x4,9	32,46*	25x9	40,88*
UNF 3/8-24h.	2	9,52	8,50	63x20x5,5	37,48*	38x10	55,77*
UNF 7/16-20h.	2	11,11	9,90	63x20x6,2	49,74	38x10	54,72
UNF 1/2-20h.	2	12,70	11,50	70x22x7,0	50,89*	38x10	59,61*
UNF 9/16-18h.	2	14,29	12,90	70x22x9,0	66,31	38x10	62,41
UNF 5/8-18h.	2	15,87	14,50	70x22x9,0	85,66*	45x14	81,33*
UNF 3/4-16h.	2	19,05	17,50	80x22x11,0	115,06*	45x14	81,33*
UNF 7/8-14h.	2	22,22	20,40	80x22x14,5	147,87*	55x16	109,17*
UNF 1"-12h.	2	25,40	23,25	90x22x16,0	196,07	55x16	109,17
UNF 1"-14h.	2	25,40	23,60	90x22x14,5	217,20*	55x16	118,62*
UNF 1.1/8-12h.	2	28,57	26,50	90x22x18,0	289,39	65x18	132,95
UNF 1.1/4-12h.	2	31,75	29,50	90x22x20,0	353,42	65x18	168,66
UNF 1.3/8-12h.	2	34,92	32,80	125x35x22,0	476,81	65x18	176,56
UNF 1.1/2-12h.	2	38,10	36,00	125x40x22,0	602,37	75x20	252,85
UNF 2"-12h.	2	50,80	48,38	140x40x29,0	1.490,51	90x22	

\* Disponibles también con rosca izquierda con 100% de recargo sobre los precios tarifados en rosca derecha



JUEGOS DE MACHOS Y TERRAJAS PARA ROSCAR A MANO HSS



Machos y Terrajas  
Verde Rosa

Uds.	D1 mm	L1 x L2 x mm	M0		C5		MOT		C5T		MOX		C5X	
			HSS	€	HSS	€	HSS	€	HSS	€	HSSCo	€	HSSCo	€
G 1/8-28h.	2	9,73	8,80	63 x 20 x 5,5	33,90*	38 x 10	49,87*	G 1/8-28 h.	2	73,77	92,97	84,76	63,22	
G 1/4-19h.	2	13,16	11,80	70 x 22 x 9,0	47,77*	38 x 10	49,60*	G 1/4-19 h.	2	134,22	96,22	152,32	65,21	
G 3/8-19h.	2	16,66	15,25	70 x 22 x 9,0	59,97*	45 x 14	65,70*	G 3/8-19 h.	2	163,75	108,24	189,22	77,57	
G 1/2-14h.	2	20,95	19,00	80 x 22 x 12,0	84,11*	45 x 14	65,70*	G 1/2-14 h.	2	230,79	122,52	255,30	85,83	
G 5/8-14h.	2	22,91	21,00	80 x 22 x 14,5	107,62*	55 x 16	91,14*							
G 3/4-14h.	2	26,44	24,50	90 x 22 x 16,0	131,29*	55 x 16	118,64*	G 3/4-14 h.	2	302,78	199,61	366,45	146,40	
G 7/8-14h.	2	30,20	28,25	90 x 22 x 18,0	176,75	65 x 18	141,24							
G 1"-11h.	2	33,25	30,75	100 x 25 x 20,0	208,14*	65 x 18	142,60*	G 1" -11 h.	2	527,71	266,63	602,73	174,90	
G 1.1/8-11h.	2	37,90	35,50	125 x 40 x 22,0	332,16	75 x 20	201,26							
G 1.1/4-11h.	2	41,91	39,50	125 x 40 x 24,0	361,97*	75 x 20	197,57*							
G 1.3/8-11h.	2	44,32	42,00	125 x 40 x 29,0	491,64	90 x 22	309,59							
G 1.1/2-11h.	2	47,80	45,25	140 x 40 x 29,0	547,04	90 x 22	298,23							
G 1.3/4-11h.	2	53,75	51,25	140 x 40 x 32,0	909,44	105 x 22	309,59							
G 2"-11h.	2	59,61	57,00	160 x 40 x 35,0	1.011,23	105 x 22	372,59							
G 2.1/4-11h.	2	65,71	63,00	160 x 40 x 39,0	1.670,44	105 x 22								
G 2.1/2-11h.	2	75,18	72,50	160 x 40 x 39,0	2.510,86	120 x 22								
G 2.3/4-11h.	2	81,53	79,00	160 x 40 x 39,0	3.044,65	120 x 22								
G 3"-11h.	2	87,88	85,50	160 x 40 x 39,0	3.168,86	150 x 25								
G 4"-11h.	2	113,03	110,50	180 x 45 x 44,0	4.806,08	180 x 25								

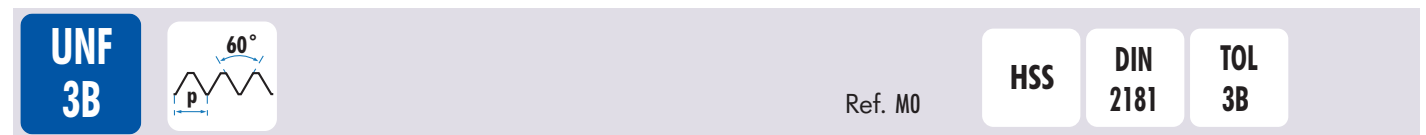

Uds.	D1 mm	L1 x L2 x mm	M0-3B	
UNF n°4-48-3B	2	2,84 2,35	40x9x2,7	52,94
UNF n°5-44-3B	2	3,17 2,70	45x10x2,7	52,94
UNF n°6-40-3B	2	3,50 2,95	45x16x3,0	52,94
UNF n°8-36-3B	2	4,17 3,50	50x12x3,4	52,94
UNF n°10-32-3B	2	4,83 4,10	50x12x4,9	52,94
UNF n°12-28-3B	2	5,49 4,60	50x12x4,9	52,94
UNF 1/4-28-3B	2	6,35 5,50	50x14x4,9	38,61
UNF 5/16-24-3B	2	7,94 6,90	56x22x4,9	41,34
UNF 3/8-24-3B	2	9,52 8,50	63x20x5,5	47,72
UNF 7/16-20-3B	2	11,11 9,90	63x20x6,2	63,36
UNF 1/2-20-3B	2	12,70 11,50	70x22x7,0	64,81

\* Disponibles también con rosca izquierda con 100% de recargo sobre los precios tarifados en rosca derecha

**JUEGOS DE MACHOS Y TERRAJAS PARA ROSCAR A MANO HSS**

**BSW** Ref. M0 HSS DIN 351 TOL Clase 2  
Ref. C5 HSS DIN 223

DIN BS84 55°



					M0		C5
	Uds.	D1 mm	$L_1 \times L_2 \times \nabla$ mm	€	Ø x L3 mm	€	
W 1/16-60h.	3	1,59	1,15	32x8x2,1	57,27	16x5	77,08
W 3/32-48h.	3	2,38	1,80	40x9x2,1	41,88	20x5	39,77
W 1/8-40h.	3	3,17	2,55	40x14x2,7	30,08*	25x9	31,39*
W 5/32-32h.	3	3,97	3,10	45x17x3,4	30,39	25x9	32,02
W 3/16-24h.	3	4,76	3,60	50x19x4,9	30,08	25x9	31,39
W 7/32-24h.	3	5,55	4,40	50x19x4,9	49,47	25x9	41,00
W 1/4-20h.	3	6,35	5,10	50x20x4,9	33,88*	25x9	32,02*
W 5/16-18h.	3	7,94	6,50	56x20x4,9	41,38*	25x9	33,40*
W 3/8-16h.	3	9,52	7,90	63x22x5,5	45,46*	38x10	48,33*
W 7/16-14h.	3	11,11	9,25	70x22x6,2	61,03	38x10	48,40
W 1/2-12h.	3	12,70	10,50	75x25x7,0	65,49	38x14	47,49
W 9/16-12h.	3	14,29	12,00	80x26x9,0	89,09	38x14	58,00
W 5/8-11h.	3	15,87	13,40	80x27x9,0	102,45*	45x18	68,97*
W 11/16-11h.	3	17,46	15,25	95x32x11,0	241,44	45x18	113,61
W 3/4-10h.	3	19,05	16,50	95x32x11,0	145,85*	45x18	69,08*
W 7/8-9h.	3	22,22	19,25	100x32x14,5	199,19*	55x22	101,57*
W 1"- 8h.	3	25,40	21,75	110x36x14,5	244,10*	55x22	102,49*
W 1.1/8-7h.	3	28,57	24,75	125x40x18,0	361,81	65x25	161,39
W 1.1/4-7h.	3	31,75	27,75	125x40x18,0	437,75	65x25	161,45
W 1.3/8-6h.	3	34,92	30,50	150x50x22,0	544,37	65x25	164,43
W 1.1/2-6h.	3	38,10	33,50	150x50x24,0	655,40	75x30	249,95
W 1.5/8-5h.	3	41,27	46,50	150x56x24,0	912,25	75x30	311,24
W 1.3/4-5h.	3	44,45	39,00	160x58x29,0	1.122,77	90x36	391,70
W 1.7/8-4,5h.	3	47,62	42,00	180x65x29,0	1.450,12	90x36	428,60
W 2"- 4,5h.	3	50,80	44,50	180x65x32,0	1.522,38	90x36	449,18
W 2.1/4-4h.	3	57,15	50,00	200x85x35,0	2.522,51	105x36	
W 2.1/2-4h.	3	63,50	56,50	220x85x39,0	3.068,68	120x36	
W 2.3/4-3,5h.	3	69,85	62,00	250x90x44,0	4.381,71	120x36	
W 3"- 3,5h.	3	76,20	68,00	250x90x44,0	5.069,15	140x36	

**BSW** **INOX** **TiN**

				MOT		C5T
	Uds.	L1 x L2 x ∇ mm	€	Ø x L3 mm	€	
W 3/16-24 h.	3	50 x 19 x 4,90	57,42	25x9	57,40	
W 1/4-20 h.	3	50 x 20 x 4,90	64,28	25x9	58,45	
W 5/16-18 h.	3	56 x 20 x 4,90	70,43	25x9	60,76	
W 3/8-16 h.	3	63 x 22 x 5,50	82,90	38x10	71,83	
W 1/2-12 h.	3	75 x 25 x 7,00	116,98	38x14	96,50	

**BSF** Ref. M0 HSS DIN 5157 TOL ISO 228  
Ref. C5 HSS DIN 223

DIN BS84 55°

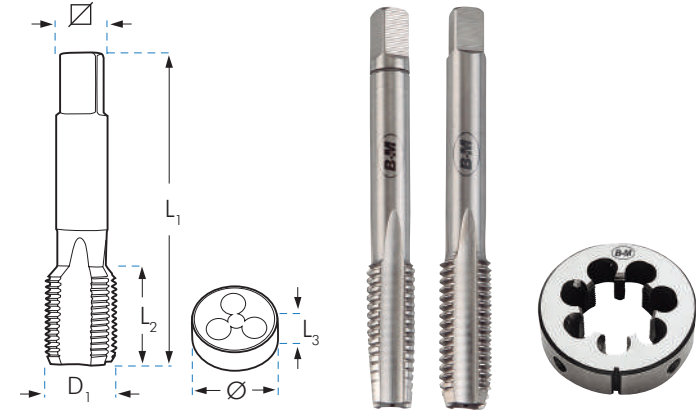

					M0		C5
	Uds.	D1 mm	$L_1 \times L_2 \times \nabla$ mm	€	Ø x L3 mm	€	
BSF 3/16-32h.	2	4,76	4,0	50x19x4,9	113,19	20x7	41,30
BSF 1/4-26h.	2	6,35	5,2	50x20x4,9	46,04	20x7	45,74
BSF 5/16-22h.	2	7,94	6,6	56x20x4,9	53,68	25x9	46,25
BSF 3/8-20h.	2	9,52	8,1	63x22x5,5	62,12	30x11	88,85
BSF 7/16-18h.	2	11,11	9,5	70x22x6,2	74,55	30x11	88,03
BSF 1/2-16h.	2	12,70	11,0	75x25x7,0	84,34	38x10	76,82
BSF 9/16-16h.	2	14,29	12,5	80x26x9,0	101,09	38x10	81,07
BSF 5/8-14h.	2	15,88	14,0	80x26x9,0	132,29	45x14	126,38
BSF 3/4-12h.	2	19,05	16,5	95x33x11,0	202,21	45x14	127,55
BSF 7/8-11h.	2	22,23	19,5	100x33x14,5	241,35	55x22	171,05
BSF 1"-10h.	2	25,40	22,5	110x40x14,5	338,78	55x22	169,15
BSF 1.1/8-9h.	2	28,57	25,5	110x40x16,0	764,42		
BSF 1.1/4-9h.	2	31,75	28,5	125x46x18,0	872,74		
BSF 1.1/2-8h.	2	38,10	34,5	150x55x22,0	1.330,10		



\* Disponibles también con rosca izquierda con 100% de recargo sobre los precios tarifados en rosca derecha

MACHOS Y TERRAJAS PARA ROSCAR A MANO HSS

**NPTF**

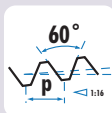

Rosca AMERICANA  
Rosca Cónica estanca

Ref. M0

**HSS**

Ref. C5

**HSS**

**DIN  
223**

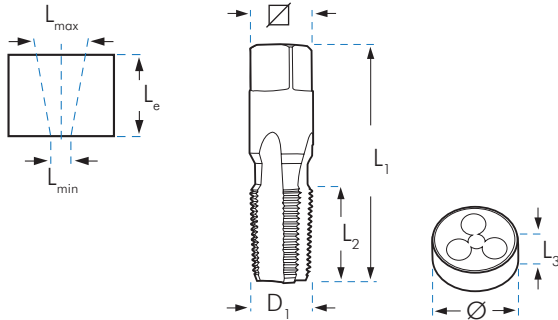

							M0	C5		
		Uds.	D <sub>1</sub> mm		L <sub>min</sub> x L <sub>max</sub> mm	L <sub>e</sub> mm	L <sub>1</sub> x L <sub>2</sub> x	€	Ø x L <sub>3</sub> mm	€
NPTF	1/8-27 h.	1	10,22	8,5	8,30 x 8,76	12,0	54 x 19 x 8,0	92,28	38 x 10	201,52
NPTF	1/4-18 h.	1	13,58	11,0	10,70 x 11,40	17,5	62 x 27 x 11,0	129,34	38 x 15	201,52
NPTF	3/8-18 h.	1	17,02	14,5	14,20 x 14,84	17,6	65 x 27 x 13,0	178,54	45 x 14	263,12
NPTF	1/2-14 h.	1	21,21	17,8	17,40 x 18,33	22,8	80 x 35 x 13,0	249,66	45 x 20	263,12
NPTF	3/4-14 h.	1	26,56	23,0	22,80 x 23,68	23,0	83 x 35 x 17,0	381,62	55 x 22	501,49
NPTF	1"-11,5 h.	1	33,19	29,0	28,60 x 29,72	27,4	110 x 38 x 20,0	508,33		

**NPT**

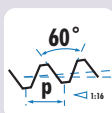

Rosca AMERICANA  
Rosca Cónica no estanca (Briggs)

Ref. M0

**HSS**

Ref. C5

**HSS**

**DIN  
223**

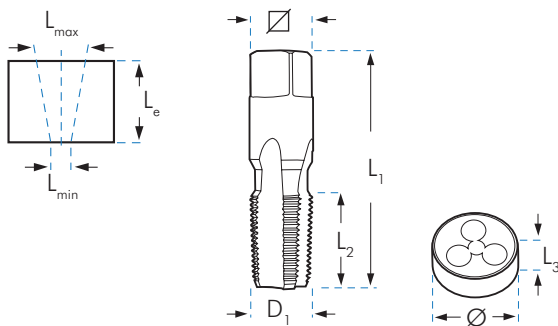

							M0	C5			
		Uds.	D <sub>1</sub> mm			L <sub>min</sub> x L <sub>max</sub> mm	L <sub>e</sub> mm	L <sub>1</sub> x L <sub>2</sub> x	€	Ø x L <sub>3</sub> mm	€
NPT	1/16-27 h.	1	7,89	6,20	EMNPT1/16	6,00 x 6,38	12,0	54 x 18 x 6,0	35,04	25 x 9	115,84
NPT	1/8-27 h.	1	10,24	8,50	EMNPT1/8	8,30 x 8,73	12,0	54 x 19 x 8,0	35,04	30 x 11	85,65
NPT	1/4-18 h.	1	13,62	11,00	EMNPT1/4	10,70 x 11,35	17,5	62 x 27 x 11,0	49,16	38 x 14	85,65
NPT	3/8-18 h.	1	17,05	14,50	EMNPT3/8	14,20 x 14,80	17,6	65 x 27 x 13,0	67,84	45 x 18	111,81
NPT	1/2-14 h.	1	21,23	17,80	EMNPT1/2	17,40 x 18,32	22,8	80 x 35 x 13,0	94,86	45 x 18	111,81
NPT	3/4-14 h.	1	26,57	23,00	-	22,80 x 23,66	23,0	83 x 35 x 17,0	145,02	55 x 22	204,55
NPT	1"-11,5 h.	1	33,23	29,00	-	28,60 x 29,69	27,4	95 x 44 x 21,0	161,51	65 x 25	245,90
NPT	1.1/4-11,5 h.	1	41,98	37,50	-	37,40 x 38,45	28,1	125 x 33 x 24,0	264,81	75 x 26	305,57
NPT	1.1/2-11,5 h.	1	48,05	44,00	-	43,40 x 44,52	28,4	140 x 33 x 29,0	402,39	90 x 27	426,32
NPT	2"-11,5 h.	1	60,09	56,00	-	55,50 x 56,56	28,4	160 x 33 x 35,0	628,21	105 x 36	593,55
NPT	2.1/2"-8h.	1	73,03	67,00	-	68,68 x 69,08	28,9	200 x 45 x 39,0	767,60		
NPT	3"-8h.	1	88,90	82,00	-	84,45 x 84,86	30,5	220 x 48 x 39,0	1.078,96		

\* Ver escariador previo pag.137



**MACHOS Y TERRAJAS PARA ROSCAR A MANO HSS**

**PG**

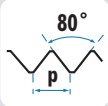

**HSS**

**DIN 40430**

Ref. M0

Ref. C5

**HSS**

**DIN 223**

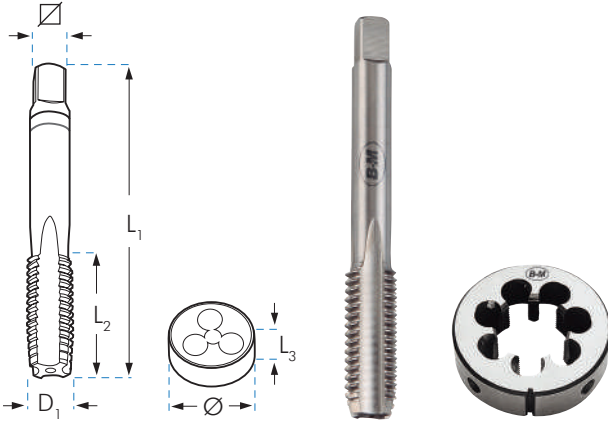

					M0	C5		
		Uds.	D1 mm		L1 x L2 x mm	€	Ø x L3 mm	€
Pg 7	20h.	1	12,5	11,50	70x20x7,0	33,59	38x10	63,57
Pg 9	18h.	1	15,2	14,00	70x20x9,0	42,71	38x10	63,57
Pg 11	18h.	1	18,6	17,25	80x22x11,0	59,30	45x14	79,59
Pg 13,5	18h.	1	20,4	19,00	80x22x12,0	65,03	45x14	79,59
Pg 16	18h.	1	22,5	21,25	80x22x14,5	78,10	55x16	102,68
Pg 21	16h.	1	28,3	27,00	90x22x18,0	114,85	65x18	145,95
Pg 29	16h.	1	37,0	35,50	100x25x22,0	228,05	65x18	145,95
Pg 36	16h.	1	47,0	45,50	140x32x29,0	385,15	90x22	374,09
Pg 42	16h.	1	54,0	52,50	140x36x32,0	457,39	105x22	374,09
Pg 48	16h.	1	59,3	58,00	160x36x35,0	576,85	105x22	496,08

**NPSF**

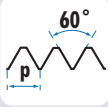

Rosca AMERICANA  
Rosca Cilíndrica estanca

**HSS**

Ref. M0

Ref. C5

**HSS**

**DIN 223**

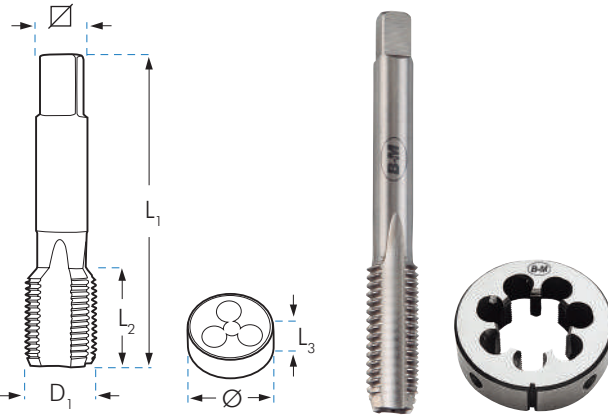

					M0	C5		
		Uds.	D1 mm		L1 x L2 x mm	€	Ø x L3 mm	€
NPSF 1/8-27 h.		1	10,05	8,75	63x18x5,5	138,96	38x10	242,08
NPSF 1/4-18 h.		1	13,35	11,30	70x20x9,0	200,80	38x10	242,08
NPSF 3/8-18 h.		1	16,78	14,70	70x20x9,0	277,75	45x14	307,95
NPSF 1/2-14 h.		1	20,87	18,20	80x22x12,0	363,09	45x14	307,95
NPSF 3/4-14 h.		1	26,23	23,50	90x22x16,0	552,46	55x16	665,65

**NPS (M)**

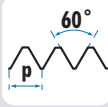

Rosca AMERICANA  
Rosca Cilíndrica no estanca

**HSS**

Ref. M0

Ref. C5

**HSS**

**DIN 223**

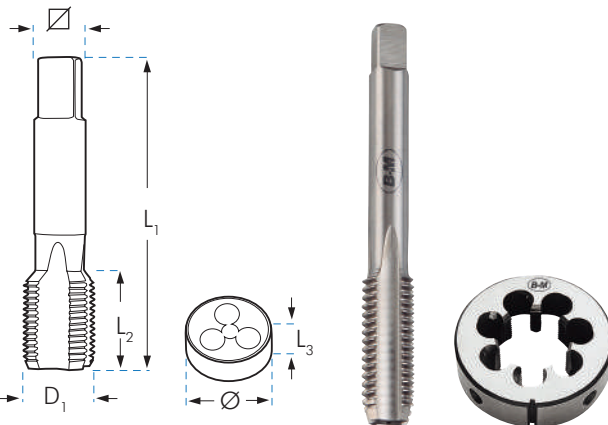

					M0	C5		
		Uds.	D1 mm		L1 x L2 x mm	€	Ø x L3 mm	€
NPS 1/8-27 h.		1	10,20	8,9	63x18x5,5	115,14	38x10	201,68
NPS 1/4-18 h.		1	13,60	11,7	70x20x9,0	91,63	38x10	201,68
NPS 3/8-18 h.		1	17,00	15,0	70x20x9,0	126,74	45x14	256,61
NPS 1/2-14 h.		1	21,20	18,6	80x22x12,0	165,65	45x14	256,61
NPS 3/4-14 h.		1	26,55	24,0	90x22x16,0	240,56	55x16	508,35
NPS 1"-11,5 h.		1	33,20	30,0	100x25x20,0	336,36	65x18	512,31

JUEGOS DE MACHOS Y TERRAJAS PARA ROSCAR A MANO HSS

BSPT

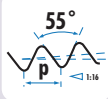

Ref. M0

HSS

DIN  
5157

Ref. C5

HSS

DIN  
223

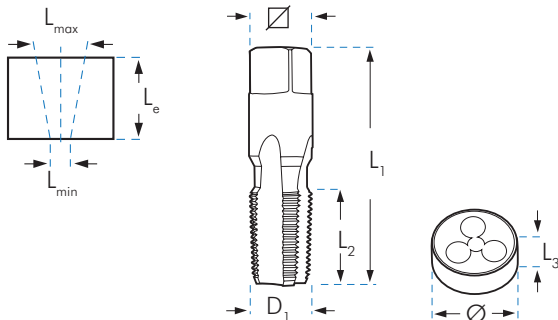

Icon	Uds.	D1 mm	Lmin x Lmax mm	Le mm	L1 x L2 x L3 mm	M0		C5	
						€	Ø x L3 mm	€	
	1	9,73	8,30	8,00 x 8,50	10,1	65 x 19 x 5,5	31,37	30 x 11	99,12
	1	13,16	11,00	10,70 x 11,35	15,0	70 x 25 x 9,0	44,20	38 x 14	99,12
	1	16,66	14,50	14,15 x 14,25	15,4	70 x 25 x 9,0	61,38	45 x 16	129,09
	1	20,95	18,10	17,60 x 18,50	20,5	80 x 31 x 12,0	85,94	55 x 22	129,09
	1	22,91	20,00	19,50 x 20,40	22,4	80 x 36 x 14,5	150,72	55 x 19	269,37
	1	26,44	23,50	23,00 x 24,00	21,8	85 x 33 x 16,0	140,24	55 x 22	243,78
	1	30,20	27,25	26,65 x 28,75	24,0	100 x 36 x 18,0	273,50	65 x 22	351,92
	1	33,25	29,60	29,00 x 30,20	26,0	110 x 38 x 20,0	222,09	65 x 25	281,51

BA

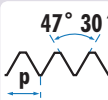

Ref. M0

HSS

DIN  
352

Ref. C5

HSS

DIN  
223

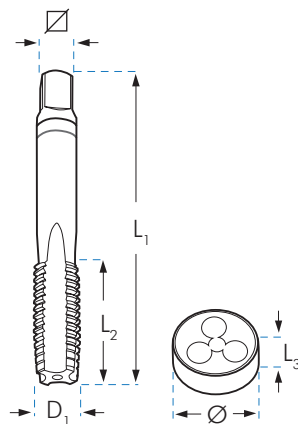

Icon	Uds.	D1 mm	L1 x L2 x L3 mm	M0		C5		
				€	Ø x L3 mm	€		
	1,00	3	6,0	5,1	50 x 18 x 4,9	195,44	20 x 5	152,80
	0,90	3	5,3	4,5	50 x 18 x 4,9	195,44	20 x 5	152,80
	0,81	3	4,7	4,0	50 x 17 x 4,9	195,44	20 x 5	152,80
	0,73	3	4,1	3,4	45 x 14 x 3,4	210,03	20 x 5	152,80
	0,66	3	3,6	3,0	45 x 14 x 3,0	210,03	20 x 5	152,80
	0,59	3	3,2	2,6	45 x 14 x 3,0	250,95	20 x 5	152,80
	0,53	3	2,8	2,3	40 x 12 x 2,7	250,95	20 x 5	152,80
	0,48	3	2,5	2,0	40 x 10 x 2,1	275,91	20 x 5	152,80
	0,43	3	2,2	1,8	36 x 10 x 2,1	275,91	20 x 5	152,80

## JUEGOS DE MACHOS Y TERRAJAS PARA ROSCAR A MANO HSS

UNx8

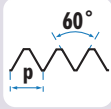

Rosca AMERICANA

Ref. M0

HSS

DIN  
2181TOL  
2B

Ref. C5

HSS

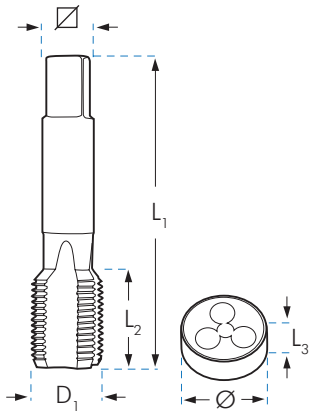
DIN  
223TOL  
2a

Uds.	D1 mm	L1 x L2 x L3 mm	M0		C5	
			€	Ø x L3 mm	€	
2	28,57	25,40 138x65x17,0	368,56	65x25	403,67	
2	31,75	28,50 146x65x19,5	477,95	65x25	403,67	
2	34,92	31,75 154x76x21,0	594,44	65x25	401,90	
2	38,10	35,00 162x76x23,5	680,29	75x30	454,98	
2	41,27	38,10 170x80x25,0	845,78	75x30	476,24	
2	44,45	41,25 178x81x27,0	1.054,08	90x36	635,00	
2	47,62	44,45 186x90x29,0	1.315,02	90x36	679,43	
2	50,80	47,63 194x90x31,5	1.250,20	90x36	687,91	
2	57,15	54,00 208x90x36,0				
2	63,50	60,35 220x100x40				
2	69,85	66,70 234x104x39				
2	76,20	73,05 248x115x49				

UNEF

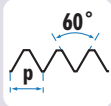

Rosca AMERICANA

Ref. M0

HSS

DIN  
2181TOL  
2B

Ref. C5

HSS

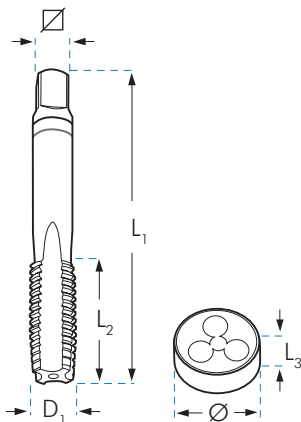
DIN  
223TOL  
2a

Uds.	D1 mm	L1 x L2 x L3 mm	M0		C5	
			€	Ø x L3 mm	€	
2	6,35	5,55 65x28x4,9	99,06	20x7	100,58	
2	7,94	7,15 70x30x6,0	110,67	25x9	100,58	
2	9,52	8,70 75x33x7,0	126,65	30x11	156,17	
2	11,11	10,20 81x38x6,0	161,22	30x11	156,17	
2	12,70	11,80 86x44x7,0	182,17	38x10	156,17	
2	14,29	13,20 92x44x8,0	197,31	38x10	156,17	
2	15,87	14,80 93x47x9,0	203,24	45x14	250,32	
2	19,05	17,80 108x52x11,0	223,68	45x14	250,32	
2	22,22	20,95 120x58x13,0	339,45	55x16	297,76	
2	25,40	24,20 130x65x15,0	349,15	55x16	305,92	



**JUEGOS DE MACHOS PARA ROSCAR A MANO APLICACIONES ESPECIALES**



Ref. M0MD

**HSSCo**  
5%

**DIN**  
352

**OX**

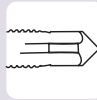

ESPECIAL MATERIALES DUROS  
( ≤ 1100 N/mm<sup>2</sup> = 40HRc )

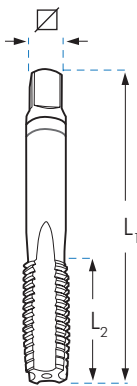

				M0MD	
	Uds.		L1 x L2 x $\nabla$ mm	€	
M 3 x 0,50	3	2,50	40 x 11 x 2,7	34,21	
M 4 x 0,70	3	3,30	45 x 13 x 3,4	34,21	
M 5 x 0,80	3	4,20	50 x 17 x 4,9	35,32	
M 6 x 1,00	3	5,00	50 x 19 x 4,9	36,37	
M 8 x 1,25	3	6,80	56 x 20 x 4,9	41,35	
M 10 x 1,50	3	8,50	70 x 22 x 5,5	53,07	
M 12 x 1,75	3	10,20	75 x 24 x 7,0	75,99	
M 14 x 2,00	3	12,00	80 x 26 x 9,0	89,95	
M 16 x 2,00	3	14,00	80 x 27 x 9,0	119,51	
M 18 x 2,50	3	15,50	95 x 30 x 11,0	183,80	
M 20 x 2,50	3	17,50	95 x 32 x 12,0	204,06	

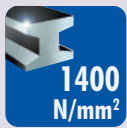

Ref. M0C

**HSS**  
PM

**TiAlSiN**



ESPECIAL MATERIALES MUY DUROS  
( ≤ 1400 N/mm<sup>2</sup> = 44HRc )

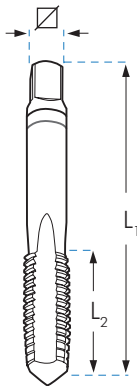

				M0C	
	Uds.		L1 x L2 x $\nabla$ mm	€	
M 3 x 0,50	3	2,50	40 x 11 x 2,7	90,03	
M 4 x 0,70	3	3,30	45 x 13 x 3,4	97,14	
M 5 x 0,80	3	4,20	50 x 17 x 4,9	98,35	
M 6 x 1,00	3	5,00	50 x 19 x 4,9	98,35	
M 8 x 1,25	3	6,80	56 x 20 x 4,9	110,86	
M 10 x 1,50	3	8,50	70 x 22 x 5,5	137,03	
M 12 x 1,75	3	10,20	75 x 24 x 7,0	166,58	
M 14 x 2,00	3	12,00	80 x 26 x 9,0	204,40	
M 16 x 2,00	3	14,00	80 x 27 x 9,0	244,91	
M 18 x 2,50	3	15,50	95 x 30 x 11,0	339,55	
M 20 x 2,50	3	17,50	95 x 32 x 12,0	373,71	

**Al**

Ref. M0AL

**HSS**

**BRILLANTE**



ESPECIAL ALUMINIO

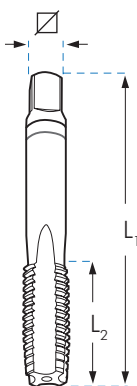

				M0AL	
	Uds.		L1 x L2 x $\nabla$ mm	€	
M 3 x 0,50	3	2,50	40 x 11 x 2,7	28,15	
M 4 x 0,70	3	3,30	45 x 13 x 3,4	27,33	
M 5 x 0,80	3	4,20	50 x 17 x 4,9	28,96	
M 6 x 1,00	3	5,00	50 x 19 x 4,9	28,96	
M 8 x 1,25	3	6,80	56 x 20 x 4,9	35,55	
M 10 x 1,50	3	8,50	70 x 22 x 5,5	43,41	
M 12 x 1,75	3	10,20	75 x 24 x 7,0	61,11	
M 14 x 2,00	3	12,00	80 x 26 x 9,0	70,23	
M 16 x 2,00	3	14,00	80 x 27 x 9,0	99,68	
M 18 x 2,50	3	15,50	95 x 30 x 11,0	132,11	
M 20 x 2,50	3	17,50	95 x 32 x 12,0	148,93	

**JUEGOS DE MACHOS Y TERRAJAS PARA ROSCAR A MANO INOXIDABLE**
**M**
**INOX**

 Ref. MOT  
 Ref. MOX

**DIN  
352**
**TOL  
6H**
**TiN**

 Ref. C5T  
 Ref. C5X

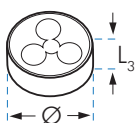
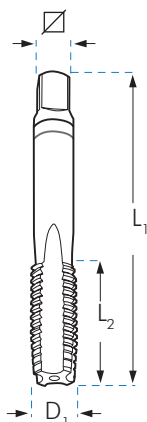
**DIN  
223**
**TOL  
6g**
**OX**

	Uds.	L1 x L2 x $\nabla$ mm	MOT	C5T	MOX	C5X	Ø x L3 mm
			HSS	HSS	HSSCo	HSSCo	
			<b>TiN</b>	<b>TiN</b>	<b>OX</b>	<b>OX</b>	
			€	€	€	€	
M 3 x 0,50	3	40 x 11 x 2,70	40,31	59,27	35,19	32,20	20 x 5
M 4 x 0,70	3	45 x 13 x 3,40	42,35	59,27	35,19	32,20	20 x 5
M 5 x 0,80	3	50 x 16 x 4,90	44,93	59,27	36,63	33,75	20 x 7
M 6 x 1,00	3	50 x 19 x 4,90	44,93	59,27	36,52	34,23	20 x 7
M 8 x 1,00	2	50 x 19 x 4,90	39,50				
M 8 x 1,25	3	56 x 22 x 4,90	51,82	60,76	42,50	37,12	25 x 9
M 10 x 1,00	2	63 x 18 x 5,50	45,58				
M 10 x 1,50	3	70 x 24 x 5,50	69,02	79,77	54,68	47,10	30 x 11
M 12 x 1,50	2	70 x 20 x 7,00	58,03				
M 12 x 1,75	3	75 x 29 x 7,00	80,08	88,45	78,30	49,76	38 x 14
M 14 x 1,50	2	70 x 20 x 9,00	69,68				
M 14 x 2,00	3	80 x 30 x 9,00	96,84	88,45	86,71	49,76	38 x 14
M 16 x 2,00	3	80 x 32 x 9,00	121,61	109,00	118,84	66,81	45 x 18
M 18 x 2,50	3	95 x 40 x 11,00	150,75		162,30		
M 20 x 2,50	3	95 x 40 x 12,00	156,33		180,15		
M 22 x 2,50	3	100 x 40 x 14,50	197,75				
M 24 x 3,00	3	110 x 50 x 14,50	238,29				

**M**

TERRAJAS HEXAGONALES HSS PARA ROSCAR A MANO

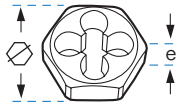

**M** HSS DIN 382

C5HM			C5HM		
		€			€
M 3 x 0,35	18 x 5	38,35	M 16 x 2,00	41 x 18	105,38
M 3 x 0,50	19 x 5	38,35	M 18 x 1,00	41 x 14	105,38
M 3,5 x 0,60	18 x 5	38,35	M 18 x 1,50	41 x 14	105,38
M 4 x 0,50	18 x 5	38,35	M 18 x 2,50	41 x 18	105,38
M 4 x 0,70	19 x 5	38,35	M 20 x 1,00	41 x 14	105,38
M 5 x 0,50	18 x 5	38,35	M 20 x 1,50	41 x 14	105,38
M 5 x 0,75	18 x 5	38,35	M 20 x 2,00	41 x 18	105,38
M 5 x 0,80	19 x 7	38,35	M 20 x 2,50	41 x 18	105,38
M 6 x 0,75	18 x 7	38,35	M 22 x 1,00	50 x 16	133,24
M 6 x 1,00	19 x 7	38,35	M 22 x 1,50	50 x 16	133,24
M 7 x 0,75	21 x 9	40,76	M 22 x 2,00	50 x 16	133,24
M 7 x 1,00	21 x 9	40,76	M 22 x 2,50	50 x 16	133,24
M 8 x 0,75	21 x 9	40,76	M 24 x 1,00	50 x 16	162,27
M 8 x 1,00	21 x 9	40,76	M 24 x 1,50	50 x 16	162,27
M 8 x 1,25	22 x 9	40,76	M 24 x 2,00	50 x 16	162,27
M 9 x 0,75	21 x 9	47,98	M 24 x 3,00	50 x 22	133,24
M 9 x 1,00	21 x 9	47,98	M 27 x 1,50	60 x 18	180,15
M 9 x 1,25	22 x 9	47,98	M 27 x 2,00	60 x 18	180,15
M 10 x 1,00	27 x 11	47,98	M 27 x 3,00	60 x 25	150,12
M 10 x 1,25	27 x 11	47,98	M 30 x 1,00	60 x 18	180,15
M 10 x 1,50	27 x 11	47,98	M 30 x 1,50	60 x 18	180,15
M 11 x 1,00	27 x 11	79,95	M 30 x 2,00	60 x 18	180,15
M 11 x 1,50	27 x 11	79,95	M 30 x 3,00	60 x 18	180,15
M 12 x 1,25	36 x 10	79,95	M 30 x 3,50	60 x 25	150,12
M 12 x 1,50	36 x 10	79,95	M 33 x 1,50	60 x 18	201,72
M 12 x 1,75	36 x 10	67,17	M 33 x 2,00	60 x 18	201,72
M 14 x 1,25	36 x 14	90,85	M 33 x 3,50	60 x 25	168,10
M 14 x 1,50	36 x 10	90,85	M 35 x 1,50	60 x 18	207,95
M 14 x 2,00	36 x 10	67,17	M 36 x 1,50	60 x 18	207,95
M 15 x 1,00	36 x 14	105,38	M 36 x 2,00	60 x 18	207,95
M 15 x 1,50	41 x 14	105,38	M 36 x 3,00	60 x 18	207,95
M 16 x 1,00	41 x 14	105,38	M 36 x 4,00	60 x 25	173,29
M 16 x 1,50	41 x 14	105,38			

**BSP (GAS)** HSS DIN 382

C5HG

		€
G 1/8 x 28h.	27 x 11	84,44
G 1/4 x 19h.	36 x 10	84,44
G 3/8 x 19h.	41 x 14	105,60
G 1/2 x 14h.	41 x 14	105,60
G 5/8 x 14h.	50 x 16	248,64
G 3/4 x 14h.	50 x 16	248,64
G 7/8 x 14h.	60 x 18	250,85
G 1" x 11h.	60 x 18	250,85
G1.1/4 x 11h.	70 x 20	334,47
G1.1/2 x 11h.	85 x 22	564,27
G 2" x 11h.	100 x 22	849,10

**UNC** HSS DIN 382

C5HNC

		€
UNC 1/4-20h	18 x 7	34,97
UNC 5/16-18h	21 x 9	43,52
UNC 3/8-16h	27 x 11	52,53
UNC 7/16-14h	27 x 11	77,52
UNC 1/2-13h	36 x 14	77,81
UNC 9/16-12h	36 x 14	92,98
UNC 5/8-11h	41 x 18	72,04
UNC 3/4-10h	41 x 18	114,59
UNC 7/8-9h	50 x 22	162,62
UNC 1"-8h	50 x 22	162,62
UNC 1.1/8-7h	60 x 25	215,01
UNC 1.1/4-7h	60 x 25	215,01

**UNF** HSS DIN 382

C5HNF

		€
UNF 1/4-28h.	18 x 7	37,07
UNF 5/16-24h.	21 x 9	46,35
UNF 3/8-24h.	27 x 11	55,76
UNF 7/16-20h.	27 x 11	82,16
UNF 1/2-20h.	36 x 10	83,42
UNF 9/16-18h.	36 x 10	92,98
UNF 5/8-18h.	41 x 14	116,00
UNF 3/4-16h	41 x 14	121,48
UNF 7/8-14h	50 x 16	153,64
UNF 1"-12h	50 x 16	161,06
UNS 1"-14h	50 x 16	161,06
UNF 1.1/8-12h	60 x 18	215,01
UNF 1.1/4-12h	60 x 18	215,01

**BSW** HSS DIN 382

C5HW			C5HW		
		€			€
BSW 1/8 x 40h.	19 x 5	47,98	BSW 9/16 x 12h.	36 x 14	71,98
BSW 3/16 x 24h.	19 x 7	47,98	BSW 5/8 x 11h.	41 x 18	106,37
BSW 1/4 x 20h.	19 x 7	47,98	BSW 3/4 x 10h.	41 x 18	106,37
BSW 5/16 x 18h.	22 x 9	50,37	BSW 7/8 x 9h.	50 x 22	155,90
BSW 3/8 x 16h.	27 x 11	59,96	BSW 1" x 8h.	50 x 22	155,90
BSW 7/16 x 14h.	27 x 11	59,96	BSW 1.1/8 x 7h.	60 x 25	268,71
BSW 1/2 x 12h.	36 x 14	71,98			



## GALGAS PARA LA COMPROBACIÓN DE PASOS DE ROSCAS



	TIPOS DE ROSCA	RANGO DE PASOS		GAM
		Métricos	Ingleses	€
GAM	Pasos rosca métrica	0,25 - 2,5		11,24
GAMW	Pasos rosca métrica /rosca Inglesa	0,25 - 6,0	62h - 4h	20,36

## CONJUNTO DE GUIAS PARA COJINETES M3-M12

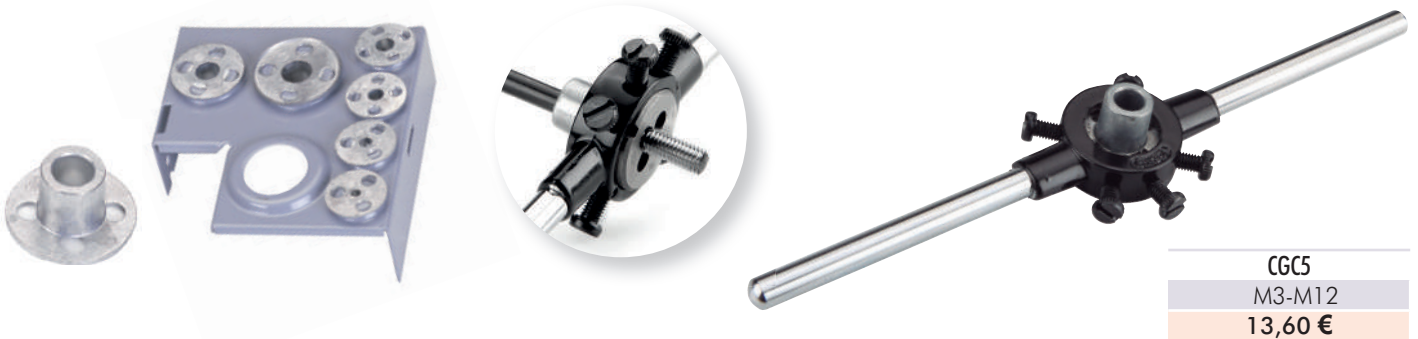

CG5  
M3-M12  
13,60 €

## ALARGADOR DE MACHOS

DIN  
377

DIN 10

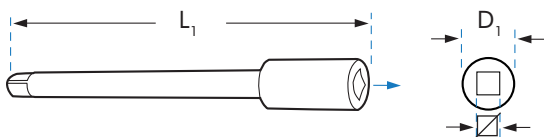

Misma medida de cuadradillo tanto en zona macho como hembra

	∅ x L1 mm	D1	AL €
AL21	2,1 x 60	6,0	8,14
AL24	2,4 x 70	6,0	8,14
AL27	2,7 x 80	7,0	8,14
AL30	3,0 x 90	7,0	8,14
AL34	3,4 x 95	8,0	8,83
AL38	3,8 x 95	9,0	9,22
AL43	4,3 x 105	10,0	10,26
AL49	4,9 x 110	11,0	10,27
AL55	5,5 x 115	12,0	10,34
AL62	6,2 x 120	14,0	12,59
AL70	7,0 x 125	15,0	13,12
AL80	8,0 x 125	17,0	16,39
AL90	9,0 x 135	19,0	16,83

	∅ x L1 mm	D1	AL €
AL100	10,0 x 140	21,0	23,25
AL110	11,0 x 150	23,0	23,58
AL120	12,0 x 160	25,0	25,39
AL130	13,0 x 165	27,0	39,72
AL145	14,5 x 175	29,0	40,27
AL160	16,0 x 185	30,0	42,61
AL180	18,0 x 195	33,0	48,56
AL200	20,0 x 220	36,0	64,76
AL220	22,0 x 220	40,0	94,65
AL240	24,0 x 235	42,0	144,96
AL260	26,0 x 245	45,0	153,07
AL290	29,0 x 260	55,0	176,60
AL320	32,0 x 280	55,0	217,41

Máxima Resistencia  
150 kg/mm<sup>2</sup>

**GIRAMACHOS DE ACERO FORJADO**

Ref. GAPRO

- Cuerpo de Acero Forjado.
- Soporta esfuerzos hasta 150 kg/mm<sup>2</sup>.
- Máxima resistencia y durabilidad.

- Mayor precisión y firmeza en el amarre.
- Su rosca de precisión conforma un conjunto sólido y robusto.
- Maneral antideslizante, mayor agarre en el taller.



GAPRO

Nº NORMA	Nº 0	Nº 1	Nº 1.1/2	Nº 2	Nº 3	Nº 4	Nº 5
	M1-M8 2,00-5,00	M1-M10 2,00-6,30	M1-M12 2,50-7,00	M1-M12 2,50-8,00	M5-M20 4,00-13,00	M5-M27 4,00-16,00	M9-M32 5,50-20,00
€	20,20	21,34	22,68	28,66	40,56	64,85	137,25

Ref. GA

- Cuerpo de Aleación de Zinc.
- Alta resistencia y durabilidad.
- Alta precisión y firmeza en el amarre.



GA

Nº NORMA	Nº 0	Nº 1	Nº 1.1/2	Nº 2	Nº 3	Nº 4	Nº 5	Nº 7	Nº 8
	M1-M8 1,50-5,00	M1-M10 2,00-7,00	M1-M12 2,00-8,00	M4-M12 2,50-10,00	M5-M20 3,50-14,00	M9-M27 4,00-15,00	M13-M32 5,50-19,00	M22-M52 14,00-34,00	M33-M64 16,00-40,00
€	16,97	17,94	19,06	24,08	34,08	54,50	115,34	234,49	372,25

**VOLVEDORES PARA TERRAJAS DE ROSCAR**

Ref. VA

DIN  
225



5

IMPORTANTE: A la hora de cursar sus pedidos de volvedores, indiquen el espesor del volvedor que corresponda, según detalle de espesores que indicamos en la tarifa de terrajas.

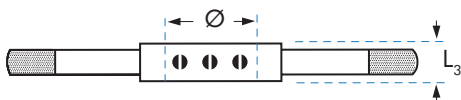

VA

Ø x L3 mm	16x5	20x5	20x7	25x9	30x11	38x10	38x14	45x14	45x18	55x16	55x22	65x18	65x25
€	9,42	10,43	10,43	11,91	14,42	18,86	18,83	23,15	23,32	29,92	31,34	42,88	42,88
Ø x L3 mm	75x20	75x30	90x22	90x36	105x22	105x36	120x22	120x36	130x25	130x36	140x25	140x36	
€	74,29	77,76	94,10	101,39	140,01	140,01	364,13	364,13	378,56	378,56	398,09	398,09	

Ref. VA

PULGADAS



3



VA

Ø mm	20,60	25,40	38,10	50,80	63,50	76,20	88,90
PULGADAS	13/16"	1"	1.1/2"	2"	2.1/2"	3"	3.1/2"
€	10,22	12,12	18,14	26,91	42,46	78,52	99,46

NOTA: Los volvedores para terrajas en Ø exteriores en pulgadas, están en desuso.

## GIRAMACHOS EN T CON CRIQUE

Ref. TC

**TIPO**  
**T**

SERIE CORTA



	CAPACIDAD mm mín.-máx.	Para mangos de machos		L <sub>1</sub> mm	PESO g	CALIDAD	TC
		DIN	ISO				€
TC3B	2,6 - 5,5	M3 - 8	M3 - 6	85	180	1ª Calidad	27,72
TC4B	4,6 - 8,0	M5 - 12	M6 - 12	110	300	1ª Calidad	37,45
TC1B	2,6 - 5,5	M3 - 8	M3 - 6	85	180	2ª Calidad	20,99
TC2B	4,6 - 8,0	M5 - 12	M6 - 12	110	300	2ª Calidad	28,15

Ref. TL

**TIPO**  
**T**

SERIE LARGA



	CAPACIDAD mm mín.-máx.	Para mangos de machos		L <sub>1</sub> mm	PESO g	CALIDAD	TL
		DIN	ISO				€
TL3	2,6 - 5,5	M3 - 8	M3 - 6	250	250	1ª Calidad	42,16
TL4	4,6 - 8,0	M5 - 12	M6 - 12	300	440	1ª Calidad	50,19
TL1	2,6 - 5,5	M3 - 10	M3 - 6	250	250	2ª Calidad	33,29
TL2	4,6 - 8,0	M5 - 12	M6 - 12	300	440	2ª Calidad	39,67

## EXPOSITOR DE METACRILATO

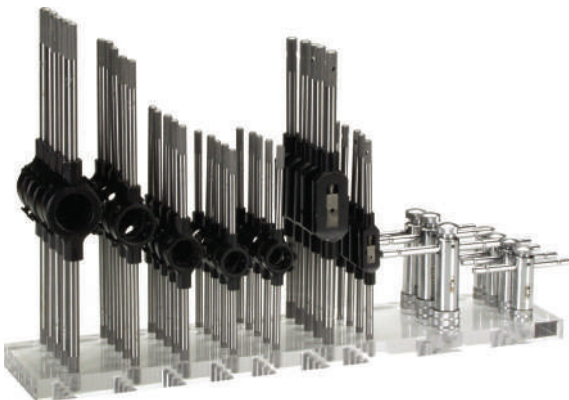

Dimensiones: 500 x 320 x 110 mm

	GV-01			€
GV-01	Nº $\frac{1}{2}$ 5	Nº 2 5	$\frac{20 \times 5}{5}$ $\frac{20 \times 7}{5}$ $\frac{25 \times 9}{5}$ $\frac{30 \times 11}{5}$ $\frac{38 \times 14}{5}$	$\frac{TC1}{4}$ $\frac{TC2}{4}$ 730,05



**CONJUNTOS DE MACHOS Y COJINETES EN CAJA METÁLICA HSS**



**M3  
M12**

**HSS**

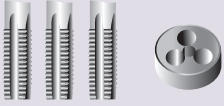

Ref. D624

**CONTENIDO**

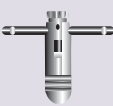
					Nº Piezas	1ª Calidad €	2ª Calidad €
D624	M3 - M4 - M5 - M6 - M8 - M10 - M12	Nº 1.1/2	25 x 9	-	30	236,56	214,59

**CONJUNTOS DE COJINETES EN CAJA METÁLICA HSS**



**M3  
M12**

**HSS**



Ref. D671

**CONTENIDO**

					Nº Piezas	1ª Calidad €	2ª Calidad €
D671	M3 - M4 - M5 - M6 - M8 - M10 - M12	20 x 5 30 x 11	20 x 7 38 x 14	25 x 9	12	233,34	197,64
D671I (lza)	 M3 - M4 - M5 - M6 - M8 - M10 - M12	20 x 5 30 x 11	20 x 7 38 x 14	25 x 9	12	466,67	395,25

**CONJUNTOS DE MACHOS Y COJINETES EN CAJA METÁLICA HSS Y HSSCo**
**M3  
M12**

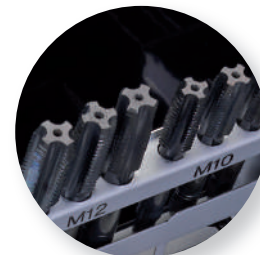
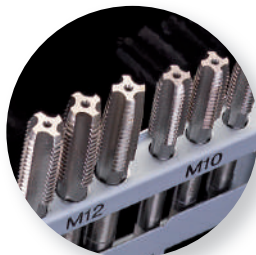
**HSS**
**HSSCo  
5%**

Ref. D621



Ref. D655

**CONTENIDO**

						Nº Piezas	1ª Calidad €	2ª Calidad €
D621	M3 - M4 - M5 - M6 M8 - M10 - M12	2.5 / 3.3 / 4.2 / 5.0 6.8 / 8.5 / 10.2 mm	Nº 1 Nº 2	20 x 5 20 x 7 25 x 9 30 x 11 38 x 14	TC1	43	474,33	347,66
D652	M3 - M4 - M5 - M6 M8 - M10 - M12	2.5 / 3.3 / 4.2 / 5.0 6.8 / 8.5 / 10.2 mm	Nº 1 Nº 2	20 x 5 20 x 7 25 x 9 30 x 11 38 x 14	-	42	459,14	330,15
D662	M3-M4-M5-M6-M7 M8-M9-M10-M11-M12	-	Nº 1 Nº 2	20 x 5 20 x 7 25 x 9 30 x 11 38 x 14	TC1	48	706,61	621,52
D651	M3 - M4 - M5 - M6 M8 - M10 - M12	-	Nº 1 Nº 2	20 x 5 20 x 7 25 x 9 30 x 11 38 x 14	-	35	362,39	333,39
D655* (HSSCo)	M3 - M4 - M5 - M6 M8 - M10 - M12	2.5 / 3.3 / 4.2 / 5.0 6.8 / 8.5 / 10.2 mm	Nº 1 Nº 2	20 x 5 20 x 7 25 x 9 30 x 11 38 x 14	TC1	43	756,68	665,59
D621I (Izq)	M3 - M4 - M5 - M6 M8 - M10 - M12	2.5 / 3.3 / 4.2 / 5.0 6.8 / 8.5 / 10.2 mm	Nº 1 Nº 2	20 x 5 20 x 7 25 x 9 30 x 11 38 x 14	TC1	43	740,80	646,04

\*

**HSSCo  
5%**



**CONJUNTOS DE MACHOS Y COJINETES EN CAJA METÁLICA HSS Y HSSCo CON GUÍAS PARA COJINETES**

**M3  
M12**

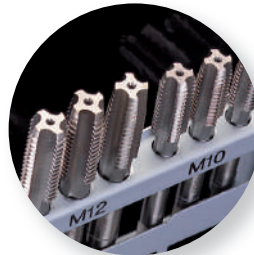

**HSS**

**HSSCo  
5%**



Ref. D656

GUÍAS



Ref. D657

GUÍAS

							Nº Piezas	1ª Calidad €	2ª Calidad €
D656	M3 - M4 - M5 - M6 M8 - M10 - M12		2.5 / 3.3 / 4.2 / 5.0 6.8 / 8.5 / 10.2 mm	Nº 1 Nº 2	+ GUÍAS		43	530,05	469,22
D657* (HSSCo)	M3 - M4 - M5 - M6 M8 - M10 - M12		2.5 / 3.3 / 4.2 / 5.0 6.8 / 8.5 / 10.2 mm	Nº 1 Nº 2			43	789,07	696,45

\* **HSSCo 5%**

**CONJUNTOS DE MACHOS Y COJINETES EN CAJA METÁLICA HSS Y HSSCo**

Machos y Terrajas

Verde

**M3  
M20**

**M5  
M20**

**HSS**

**HSSCo  
5%**



Ref. D622



Ref. D623

**CONTENIDO**

						Nº Piezas	1ª Calidad €	2ª Calidad €
D622	M3 - M4 - M5 - M6 - M8 - M10 - M12 M14 - M16 - M18 - M20	Nº 1 Nº 3	20 x 5 20 x 7 25 x 9 30 x 11 38 x 14 45 x 18	TC1 TC2	54	811,27	637,40	
D658	M3 - M4 - M5 - M6 - M8 - M10 - M12 M14 - M16 - M18 - M20	Nº 1 Nº 3	20 x 5 20 x 7 25 x 9 30 x 11 38 x 14 45 x 18	-	52	747,37	576,67	
D622i (Izq)	M3 - M4 - M5 - M6 - M8 - M10 - M12 M14 - M16 - M18 - M20	Nº 1 Nº 3	20 x 5 20 x 7 25 x 9 30 x 11 38 x 14 45 x 18	TC1 TC2	54	1397,07	1324,58	
D659* (HSSCo)	M3 - M4 - M5 - M6 - M8 - M10 - M12 M14 - M16 - M18 - M20	Nº 1 Nº 3	20 x 5 20 x 7 25 x 9 30 x 11 38 x 14 45 x 18	-	52	1685,18	1482,28	
D623	M5 - M6 - M8 - M10 - M12 M14 - M16 - M18 - M20	Nº 1 Nº 3	20 x 7 25 x 9 30 x 11 38 x 14 45 x 18	TC1 TC2	45	850,57	665,91	
D663	M5 - M6 - M7 - M8 - M9 - M10 - M12 M14 - M16 - M18 - M20	Nº 1 Nº 3	20 x 7 25 x 9 30 x 11 38 x 14 45 x 18	-	51	1.133,99	1.020,00	

\* **HSSCo 5%**



**CONJUNTOS DE MACHOS Y COJINETES EN CAJA METÁLICA Y DE MADERA HSS**

- M1  
M10
- M5  
M12
- M3  
M24
- M5  
M30
- HSS



Ref. D628



Ref. D626

**CONTENIDO**

					Nº Piezas	1ª Calidad €	2ª Calidad €
D626	M1 - M1.2 - M1.4 - M1.7 - M2.0 - M2.3 M2.6 - M3 - M3.5 - M4 - M5 - M6 - M8 - M10	Nº 0 Nº 1	16 x 5   20 x 5   20 x 7 25 x 9   30 x 11	TC1	64		1.061,05
D627	M5 - M6 - M7 - M8 - M9 - M10 - M11 - M12	Nº 1 Nº 2	20 x 7   25 x 9 30 x 11   38 x 14	TC1	39		792,65
D625	M3 - M4 - M5 - M6 - M8 - M10 - M12 - M14 M16 - M18 - M20 - M22 - M24	Nº 1 Nº 4	20 x 5   20 x 7   25 x 9 30 x 11   38 x 14   45 x 18 55 x 22	-	61	1.872,17	1.381,36
D628	M5 - M6 - M8 - M10 - M12 - M14 - M16 M18 - M20 - M22 - M24 - M27 - M30	Nº 1 Nº 3 Nº 5	20 x 7   25 x 9   30 x 11 38 x 14   45 x 18   55 x 22 65 x 25	-	62		2.528,41

**CONJUNTOS DE MACHOS Y COJINETES EN CAJA METÁLICA HSS**

**MF**

**HSS**

Machos y Terrajas

Verde







Ref. D634

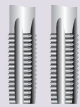

Ref. D636

**CONTENIDO**

						Nº Piezas	1ª Calidad €	2ª Calidad €
D634	MF 3 x 0.35 - 4 x 0.5 - 5 x 0.5 MF 6 x 0.75 - 8 x 0.75 - 8 x 1.0 MF 10 x 1.0 - 12 x 1.5		Nº 1 Nº 2	20 x 5 25 x 9 30 x 11 38 x 10		TC1	31	727,24
D635	MF 6 x 0.75 - 8 x 0.75 - 8 x 1.0 - 10 x 1.0 MF 12 x 1.0 - 12 x 1.5 - 14 x 1.25 - 14 x 1.5 MF 16 x 1.5 - 18 x 1.5 - 20 x 1.5		Nº 1 Nº 3	20 x 7 25 x 9 30 x 11 38 x 10 45 x 14	-		40	1.186,27 1.128,06
D636	MF 6 x 0.75 - 8 x 0.75 - 8 x 1.0 - 10 x 1.0 MF 12 x 1.0 - 12 x 1.5 - 14 x 1.25 - 14 x 1.5 MF 16 x 1.5 - 18 x 1.5 - 20 x 1.5 - 22 x 1.5 MF 24 x 1.5		Nº 1 Nº 4	20 x 7 25 x 9 30 x 11 38 x 10 45 x 14 55 x 16	-		47	1.627,35 1.504,59

**CONJUNTOS DE MACHOS Y COJINETES EN CAJA METÁLICA HSS**





**BSP  
(GAS)**

**HSS**

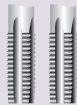

Ref. D638

**CONTENIDO**

						Nº Piezas	1ª Calidad €	2ª Calidad €
D637	G 1/8 - 1/4 - 3/8 - 1/2 - 3/4 - 1"		Nº 1 Nº 3 Nº 5	30 x 11 38 x 10 45 x 14 55 x 16 65 x 18	-	26	1.317,13	1.063,96
D638	G 1/8 - 1/4 - 3/8 - 1/2 - 5/8 - 3/4 - 7/8 - 1"		Nº 1 Nº 3 Nº 5	30 x 11 38 x 10 45 x 14 55 x 16 65 x 18	-	32	1.787,48	1.560,34
D639	G 1/4 - 3/8 - 1/2 - 3/4 - 1" - 1".1/4 - 1".1/2		Nº 2 Nº 4 Nº 7	38 x 10 45 x 14 55 x 16 65 x 18 75 x 20 90 x 22	-	30	3.297,60	2.781,66



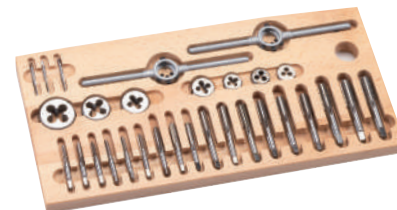

**BSW**

**HSS**

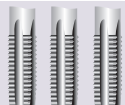

Ref. D640

**CONTENIDO**

						Nº Piezas	1ª Calidad €	2ª Calidad €
D640	BSW 1/8 - 3/16 - 1/4 - 5/16 - 3/8 - 7/16 - 1/2		Nº 1 Nº 2	20 x 5 20 x 7 25 x 9 30 x 11 38 x 14	TC1	36	734,77	628,12
D641	BSW 1/4 - 5/16 - 3/8 - 7/16 - 1/2		Nº 1 Nº 2	20 x 7 25 x 9 30 x 11 38 x 14	TC1	27	605,73	510,19
D642	BSW 1/4 - 5/16 - 3/8 - 7/16 - 1/2 - 5/8 - 3/4		Nº 1 Nº 3	20 x 7 25 x 9 30 x 11 38 x 14 45 x 18	-	35	1.084,03	989,13
D643	BSW 1/4 - 5/16 - 3/8 - 7/16 1/2 - 5/8 - 3/4 - 7/8 - 1"		Nº 1 Nº 4	20 x 7 25 x 9 30 x 11 38 x 14 45 x 18 55 x 22	-	44	1.533,07	1.345,98
D646	BSW 1/4 - 5/16 - 3/8 - 7/16 1/2 - 5/8 - 3/4 - 7/8 - 1" - 1".1/8 1".1/4 - 1".3/8 - 1".1/2		Nº 1 Nº 3 Nº 5	20 x 7 25 x 9 30 x 11 38 x 14 45 x 18 55 x 22 65 x 25	-	62		4.090,11

**CONJUNTOS DE MACHOS Y COJINETES EN CAJA METÁLICA HSS**





**BSF**

**HSS**

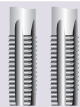

Ref. D648

**CONTENIDO**

						Nº Piezas	1ª Calidad €	2ª Calidad €	
D664	BSF 1/4 - 5/16 - 3/8 - 7/16 - 1/2		Nº 1 Nº 2	20 x 7 25 x 9 30 x 11 38 x 10		TC1	22	677,38	595,81
D648	BSF 1/4 - 5/16 - 3/8 - 7/16 - 1/2 - 5/8 - 3/4		Nº 1 Nº 3	20 x 7 25 x 9 30 x 11 38 x 10 45 x 14		-	28	1.051,56	989,13
D665	BSF 1/4 - 5/16 - 3/8 - 7/16 - 1/2 - 5/8 - 3/4 - 7/8 - 1"		Nº 1 Nº 4	20 x 7 25 x 9 30 x 11 38 x 10 45 x 14 55 x 16		-	35	1.784,32	1.569,47



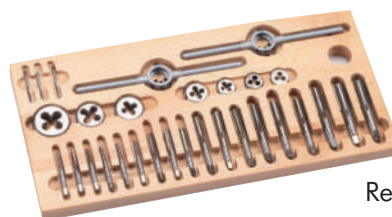

**BSW  
BSF**

**HSS**

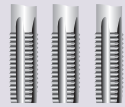

Ref. D666

**CONTENIDO**

						Nº Piezas	1ª Calidad €	2ª Calidad €	
D666	BSW 1/4 - 5/16 - 3/8 - 7/16 - 1/2 - 5/8 - 3/4 BSF 1/4 - 5/16 - 3/8 - 7/16 - 1/2 - 5/8 - 3/4		Nº 1 Nº 3	20 x 7 25 x 9 30 x 11 38 x 14 45 x 18		-	63	2.015,62	1.772,92







**CONJUNTOS DE MACHOS Y COJINETES EN CAJA METÁLICA HSS**



Ref. D660





**CONTENIDO**

						Nº Piezas	1ª Calidad €	2ª Calidad €
D660	NPT 1/8 - 1/4 - 3/8 - 1/2 - 3/4 - 1"		Nº1 Nº3 Nº5	30 x 11 38 x 14 45 x 18 55 x 22 65 x 25	-	20	1.905,28	1.807,25
D661	NPT 1/8 - 1/4 - 3/8 - 1/2 - 3/4 1" - 1".1/4 - 1".1/2 - 2"		Nº 2 Nº 4 Nº 7	30 x 11 38 x 14 45 x 18 55 x 22 65 x 25 75 x 30 90 x 36 105 X 36	-	29	5.703,44	5.358,36

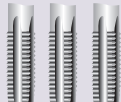

Ref. D650

**CONTENIDO**

						Nº Piezas	1ª Calidad €	2ª Calidad €
D650	UNC 1/4 - 5/16 - 3/8 - 7/16 - 1/2		Nº 1 Nº 2	20 x 7 25 x 9 30 x 11 38 x 14	TC1	27	738,31	662,67
D667	UNC 1/4 - 5/16 - 3/8 - 7/16 - 1/2 - 5/8 - 3/4		Nº 1 Nº 2	20 x 7 25 x 9 30 x 11 38 x 14 45 x 18	-	35	1.189,55	1.046,31
D654	UNC 1/4 - 5/16 - 3/8 - 7/16 1/2 - 5/8 - 3/4 - 7/8 - 1"		Nº 1 Nº 4	20 x 7 25 x 9 30 x 11 38 x 14 45 x 18 55 x 22	-	44	1.919,44	1.796,36
D668	UNC 1/4 - 5/16 - 3/8 - 7/16 - 1/2 - 5/8 - 3/4 7/8 - 1" - 1.1/8 - 1".1/4 - 1".3/8 - 1".1/2"		Nº 1 Nº 3 Nº 6	20 x 7 25 x 9 30 x 11 38 x 14 45 x 18 55 x 22 65 x 25	-	62	4.493,82	3.952,73

**CONJUNTOS DE MACHOS Y COJINETES EN CAJA METÁLICA HSS**





**UNF**

**HSS**



Ref. D644

**CONTENIDO**

						Nº Piezas	1ª Calidad €	2ª Calidad €
D644	UNF 1/4 - 5/16 - 3/8 - 7/16 - 1/2		Nº 1 Nº 2	20 x 7 25 x 9 30 x 11 38 x 10	TC1	22	578,54	501,54
D669	UNF 1/4-5/16 -3/8 -7/16 -1/2 -5/8 -3/4		Nº 1 Nº 3	20 x 7 25 x 9 30 x 11 38 x 10 45 x 14	-	28	1.090,41	959,11
D645	UNF 1/4 - 5/16 - 3/8 - 7/16 - 1/2 - 5/8 3/4 - 7/8 - 1"		Nº 1 Nº 4	20 x 7 25 x 9 30 x 11 38 x 10 45 x 14 55 x 16	-	34	1.337,06	1.212,31



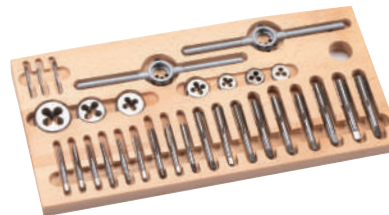

**UNC  
UNF**

**HSS**

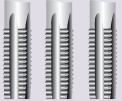

Ref. D670

**CONTENIDO**

						Nº Piezas	1ª Calidad €	2ª Calidad €
D670	UNC 1/4 - 5/16 - 3/8 - 7/16 - 1/2 - 5/8 - 3/4 UNF 1/4 - 5/16 - 3/8 - 7/16 - 1/2 - 5/8 - 3/4		Nº 1 Nº 3	20 x 7 25 x 9 30 x 11 38 x 14 45 x 18	-	35	2.015,62	1.772,92

JUEGOS DE MACHOS DE MANO HSS Y TiN EN ESTUCHES METÁLICOS



Ref. JMB0









Ref. JMB2

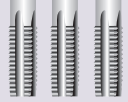

Ref. JMBT2

CONTENIDO

					HSS €		TiN* €
JMB2	M3 - M4 - M5 - M6 M8 - M10 - M12	-	-	-	187,29	JMBT2	371,88
JMB0	M3 - M4 - M5 - M6 M8 - M10 - M12	2.5 / 3.3 / 4.2 / 5.0 6.8 / 8.5 / 10.2 mm	-	-	213,64	JMBT0	417,32
JMB1	M3 - M4 - M5 - M6 M8 - M10 - M12	2.5 / 3.3 / 4.2 / 5.0 6.8 / 8.5 / 10.2 mm	Nº 1.1/2	-	229,93	JMBT1	357,60
JMB5	M3 - M4 - M5 - M6 M8 - M10 - M12	2.5 / 3.3 / 4.2 / 5.0 6.8 / 8.5 / 10.2 mm	Nº 1.1/2	TC1	244,22	JMBT5	374,71
JMBI2 (lza)	 M3 - M4 - M5 - M6 M8 - M10 - M12	-	-	-	347,33	JMBIT2	646,02
JMBI0 (lza)	 M3 - M4 - M5 - M6 M8 - M10 - M12	2.5 / 3.3 / 4.2 / 5.0 6.8 / 8.5 / 10.2 mm	-	-	402,36	JMBIT0	700,70
JMBI1 (lza)	 M3 - M4 - M5 - M6 M8 - M10 - M12	2.5 / 3.3 / 4.2 / 5.0 6.8 / 8.5 / 10.2 mm	Nº 1.1/2	-	418,07	JMBIT1	715,22

MACHOS TERCEROS DE MANO HSS Y TiN EN ESTUCHES METÁLICOS









Ref. JMB3



Ref. JMB4

CONTENIDO



3°					HSS €		TiN* €
JMB3	M3 - M4 - M5 - M6 M8 - M10 - M12	-	-	-	85,98	JMBT3	107,67
JMB4	M3 - M4 - M5 - M6 M8 - M10 - M12	2.5 / 3.3 / 4.2 / 5.0 6.8 / 8.5 / 10.2 mm	-	-	107,01	JMBT4	142,24
JMB7	M3 - M4 - M5 - M6 M8 - M10 - M12	2.5 / 3.3 / 4.2 / 5.0 6.8 / 8.5 / 10.2 mm	Nº 1.1/2	-	122,45	JMBT7	197,30
JMB6	M3 - M4 - M5 - M6 M8 - M10 - M12	2.5 / 3.3 / 4.2 / 5.0 6.8 / 8.5 / 10.2 mm	Nº 1.1/2	TC1	132,59	JMBT6	210,29
JMBI3 (lza)	 M3 - M4 - M5 - M6 M8 - M10 - M12	-	-	-	115,76	JMBIT3	215,33
JMBI4 (lza)	 M3 - M4 - M5 - M6 M8 - M10 - M12	2.5 / 3.3 / 4.2 / 5.0 6.8 / 8.5 / 10.2 mm	-	-	155,13	JMBIT4	285,43



**MACHOS DE MANO HSSCo EN ESTUCHES METÁLICOS**
**HSSCo**  
**5%**

Ref. JMBX0

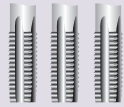
**CONTENIDO**

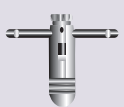
INOX	 MOX	 HSSCo			€
JMBX0	M3 - M4 - M5 - M6 M8 - M10 - M12	2.5 / 3.3 / 4.2 / 5.0 6.8 / 8.5 / 10.2 mm	-	-	295,23
JMBX1	M3 - M4 - M5 - M6 M8 - M10 - M12	2.5 / 3.3 / 4.2 / 5.0 6.8 / 8.5 / 10.2 mm	Nº 1.1/2	-	310,71
JMBX2	M3 - M4 - M5 - M6 M8 - M10 - M12	-	-	-	279,17

**CONTENIDO**

 1100 N/mm <sup>2</sup>	 MOMD	 HSSCo			€
JMBMD0	M3 - M4 - M5 - M6 M8 - M10 - M12	2.5 / 3.3 / 4.2 / 5.0 6.8 / 8.5 / 10.2 mm	-	-	308,32
JMBMD1	M3 - M4 - M5 - M6 M8 - M10 - M12	2.5 / 3.3 / 4.2 / 5.0 6.8 / 8.5 / 10.2 mm	Nº 1.1/2	-	324,36
JMBMD2	M3 - M4 - M5 - M6 M8 - M10 - M12	-	-	-	293,90

**ESTUCHES DE COJINETES EN CAJAS METÁLICAS HSS**



Ref. C5B3

**CONTENIDO**

		HSS €
C5B3	M3 - M4 - M5 - M6 - M8 - M10 - M12	223,76
C5B3I (Izq)	M3 - M4 - M5 - M6 - M8 - M10 - M12	443,19

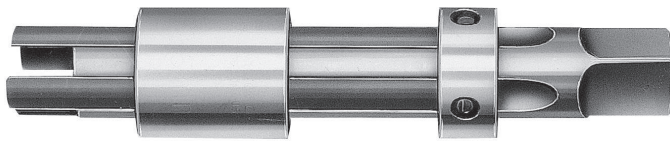

**EXTRACTOR DE MACHOS ROTOS PARA MACHOS DE CANALES RECTOS - NO HELICOIDALES**



**EXTRACTORES SUELTOS**

Ø MACHO A EXTRAER		MACHOS DE MANO	MACHOS DE MÁQUINA	€/ Ud.
BSW UNC	M			EXTRACTOR COMPLETO
--	M3		W10043	42,67
1/8	M3,2		W10053	42,67
--	M3,5		W10063	42,67
5/32	M4		W10083	42,67
3/16	M5		W10103	42,67
--	M5,5	W10124	W10123	42,67
1/4	M6	W10254	W10253	43,92
5/16	M8	W10314	W10313	46,03
--	M9	W10374	W10373	45,59
3/8	M10	W10404	W10373	45,59
7/16	M11	W10434	W10433	48,13
1/2	M12	W10504	W10503	51,46
9/16	M14	W10564	W10563	71,12
5/8	M16	W10624	W10623	77,41
--	M18	W10684	W10753	95,91
3/4	M20	W10754	W10753	95,91
7/8	M22	W10874	W10873	104,94
1"	M25	W11004	W11003	117,03

**VARILLA REPUESTO**

MACHOS DE MANO	MACHOS DE MÁQUINA	€/ Ud.
		VARILLA EXTRA
	W12043	2,27
	W12053	2,27
	W12063	2,27
	W12083	2,27
	W12103	3,39
	W12123	3,39
	W12253	4,13
W12314	W12313	4,66
W12374		4,66
W12404	W12373	4,81
W12434	W12433	4,89
W12504	W12503	6,15
W12564	W12563	6,86
W12624	W12623	8,77
W12684		8,77
W12754	W12753	9,28
W12874	W12873	12,03
W13004	W13003	20,02

**3 SIMPLES PASOS PARA EXTRAER MACHOS DE ROSCAR ROTOS DE CANALES RECTOS**

Sacar toda la viruta del macho roto. Introducir las varillas del extractor en los canales del macho roto con firmeza hasta el fondo.

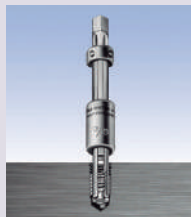

Empujar el soporte hacia abajo, hasta tocar el macho roto. Deslice el casquillo hacia abajo, hasta tocar la zona de trabajo.

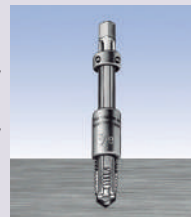

Aplicar al cuadradillo del extractor un gira-machos. Gire a izquierdas unas cuantas veces hasta soltarlo y entonces saque el macho roto.

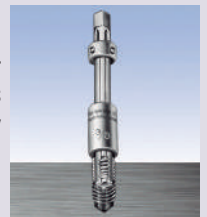

**JUEGOS DE EXTRACTORES PARA MACHOS ROTOS (CANALES RECTOS)**

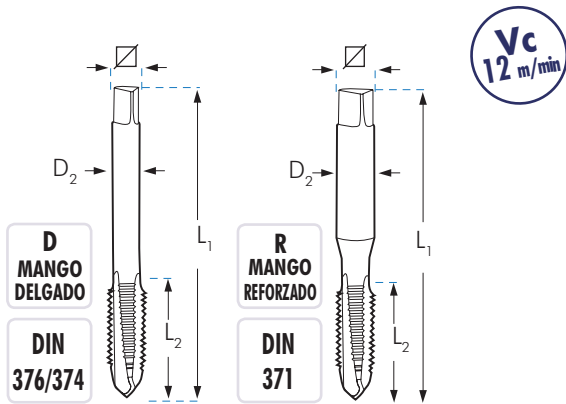
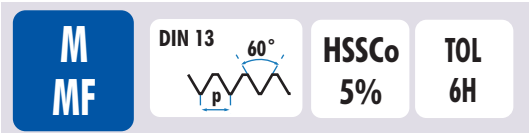

Nº CANALES	MEDIDAS INCLUIDAS PARA MACHOS DE MÁQUINA Y DE MANO: 3 y 4 CANALES	
W180013	3 M5- M6- M8- M10- M11- M12	295,82
W180014	4 3/16 - 1/4 - 5/16 - 3/8 - 7/16 - 1/12	
W180023	3 M6- M8 -M10- M11- M12- M16	332,82
W180024	4 1/4 - 5/16 - 3/8 - 7/16 - 1/12 - 5/8	
W180153	3 M3- M3,2- M3,5- M4-M5- M5,50- M6- M8	930,97
W180154	4 M9- M10- M12- M16- M18- M22- M25	

**MACHOS PARA ROSCAR A MÁQUINA HSSCo**

Icono	D	L1	L2	D2	R	L1	L2	D2	M1D	M2D	M3D	M4D	M1R	M2R	M3R	M4R
													FORMA C	FORMA B	FORMA C	FORMA B
									€	€	€	€	€	€	€	€
	M 1x0,25	0,75			R								39,76			
	M 1,1x0,25	0,85			R								38,68			
	M 1,2x0,25	0,95			R								35,33			
	M 1,4x0,30	1,10			R								35,33			
	M 1,6x0,35	1,25			R								34,70			
	M 1,7x0,35	1,35			R								33,41			
	M 1,8x0,35	1,45			R								32,59			
	M 2x0,40	1,60			R								15,69	17,71	19,80	20,18
	M 2,2x0,45	1,75			R								16,96			
	M 2,3x0,40	1,90			R								15,62			
	M 2,5x0,45	2,05			R								15,69	17,71	27,84	20,18
	M 2,6x0,45	2,10			R								15,72	18,03		33,54
	M 3x0,50	2,50			R				10,79	11,69	15,96	14,02	10,59*	10,96	15,79	14,37
	M 3x0,60	2,40			R								18,48	20,54		27,13
	M 3,5x0,60	2,90			R								15,11	16,02	20,69	19,42
	M 3,5x0,75	2,75			R								19,97			
	M 4x0,50	3,50			R				23,41	25,06		27,25	21,75	24,65		28,54
	M 4x0,70	3,30			R				10,98	11,81	16,80	13,89	11,83*	11,47	15,44	14,38
	M 4x0,75	3,25			R								16,54	17,99		
	M 4x0,80	3,20			R								87,80			
	M 4,5x0,50	4,00			R									28,68		
	M 4,5x0,75	3,75			R								20,41	22,90		
	M 5x0,50	4,50			R				24,10	25,75		27,56	22,40	25,33		30,45
	M 5x0,75	4,50			R								20,09	24,01		30,25
	M 5x0,80	4,20			R				10,98	11,76	16,10	13,33	10,89*	11,49	14,81	13,79
	M 5x0,90	4,10			R								17,48	22,93		
	M 5x1,00	4,00			R								46,81			
	M 5,5x0,90	4,60			R								46,81			
	M 6x0,50	5,50			R				28,54	34,03		44,15	29,33			
	M 6x0,75	5,25			R				18,80	21,17		25,42	19,00	22,55		27,08
	M 6x1,00	5,00			R				12,52	12,89	16,84	14,62	12,39*	12,60	16,25	15,12

\* Disponibles también con rosca izquierda con 100% de recargo sobre los precios tarifados en rosca derecha



**MACHOS PARA ROSCAR A MÁQUINA HSSCo**

**M MF** **DIN 13** **60°** **HSSCo** **5%** **TOL** **6H** **D MANGO DELGADO** **DIN 376/374** **Vc** **12 m/min** **R MANGO REFORZADO** **DIN 371**

M	L1 x L2 x D2 x mm	R	M1D		M2D		M3D		M4D		MTR		M2R		M3R		M4R	
			FORMA C	FORMA B	FORMA C	FORMA B	15°	35°	FORMA C	FORMA B	15°	35°	FORMA C	FORMA B	15°	35°	FORMA C	FORMA B
			€	€	€	€	€	€	€	€	€	€	€	€	€	€	€	€
M 6x1,25	4,75	R	80 x 17 x 6,0 x 4,9								46,01							
M 7x0,75	6,25	D	80 x 13 x 5,5 x 4,3	24,21	26,11				33,16									
<b>M 7x1,00</b>	<b>6,00</b>	R	80 x 17 x 7,0 x 5,5	16,23	18,76	20,27	20,06				15,92*	18,58	21,01	20,79				
M 8x0,50	7,50	D	80 x 13 x 6 x 4,9	31,66														
M 8x0,75	7,25	D	80 x 13 x 6 x 4,9	22,94	28,13				35,87									
M 8x1,00	7,00	D	90 x 20 x 6 x 4,9	18,76	21,53	25,80	24,53											
<b>M 8x1,25</b>	<b>6,80</b>	R	90 x 20 x 8 x 6,2	14,05	14,40	19,53	17,07				14,00*	14,14	19,25	17,11				
M 8x1,50	6,50	D	90 x 20 x 6 x 4,9	92,79														
M 9x1,00	8,00	D	90 x 20 x 7 x 5,5	28,37	30,33				32,23									
<b>M 9x1,25</b>	<b>7,80</b>	R	90 x 20 x 9 x 7,0	22,80	23,95	29,01	28,36				23,00	23,74	29,79	30,00				
M 10x0,50	9,50	D	90 x 20 x 7 x 5,5	91,94														
M 10x0,75	9,25	D	90 x 16 x 7 x 5,5	36,37	36,44				44,38									
M 10x1,00	9,00	D	90 x 16 x 7 x 5,5	20,77	23,93	30,46	29,02											
M 10x1,25	8,80	D	100 x 22 x 7 x 5,5	23,78	28,61	33,20	31,62											
<b>M 10x1,50</b>	<b>8,50</b>	R	100 x 22 x 10 x 8,0	15,73	17,75	23,01	20,26				15,87	17,42	21,49	20,26				
M 11x0,75	10,25	D	90 x 20 x 8 x 6,2															
M 11x1,00	10,00	D	90 x 20 x 8 x 6,2	37,23	38,45	97,21	88,46											
M 11x1,25	9,75	D	100 x 22 x 8 x 6,2	35,62	39,58	97,21	78,96											
<b>M 11x1,50</b>	<b>9,50</b>	D	100 x 22 x 8 x 6,2	28,88	33,82	70,88	64,47											
M 12x0,75	11,25	D	100 x 22 x 9 x 7,0	54,55														
M 12x1,00	11,00	D	100 x 22 x 9 x 7,0	28,25	32,33	37,58	37,17											
M 12x1,25	10,75	D	100 x 22 x 9 x 7,0	28,60	31,76	35,98	35,59											
M 12x1,50	10,50	D	100 x 22 x 9 x 7,0	25,56*	28,33	34,60	34,23											
<b>M 12x1,75</b>	<b>10,20</b>	D	100 x 24 x 9 x 7,0	18,94*	21,96	30,27	26,09											
M 13x0,75	12,25	D	100 x 22 x 11 x 9,0	95,21														
M 13x1,00	12,00	D	100 x 22 x 11 x 9,0	50,42	57,09													
M 13x1,25	11,75	D	100 x 22 x 11 x 9,0	50,42	57,09													
M 13x1,50	11,50	D	100 x 22 x 11 x 9,0	50,42	57,09													
<b>M 13x1,75</b>	<b>11,25</b>	D	100 x 22 x 11 x 9,0	50,06	57,09													
M 14x0,75	13,25	D	100 x 22 x 11 x 9,0	95,21														
M 14x1,00	13,00	D	100 x 22 x 11 x 9,0	45,47	50,02	57,94	57,45											
M 14x1,25	12,80	D	100 x 22 x 11 x 9,0	38,70	42,24	53,14	50,62											
M 14x1,50	12,50	D	100 x 22 x 11 x 9,0	30,44*	33,54	41,91	39,92											
<b>M 14x2,00</b>	<b>12,00</b>	D	110 x 26 x 11 x 9,0	30,24*	33,60	38,94	38,94											
M 15x1,00	14,00	D	100 x 22 x 12 x 9,0	57,83	61,22		77,95											
M 15x1,25	13,75	D	100 x 22 x 12 x 9,0	61,94	67,07													
M 15x1,50	13,50	D	100 x 22 x 12 x 9,0	49,50	56,46	144,24	117,00											
<b>M 15x2,00</b>	<b>13,00</b>	D	110 x 27 x 12 x 9,0	60,60	66,69													
M 16x1,00	15,00	D	100 x 22 x 12 x 9,0	54,50	57,83	81,12	78,76											
M 16x1,25	14,75	D	100 x 22 x 12 x 9,0	58,32	64,11	90,21	87,36											
M 16x1,50	14,50	D	100 x 22 x 12 x 9,0	35,99*	41,94	52,22	49,75											
<b>M 16x2,00</b>	<b>14,00</b>	D	110 x 27 x 12 x 9,0	35,59*	39,30	47,04	47,04											
M 17x1,00	16,00	D	100 x 22 x 12 x 9,0	108,44														
M 17x1,25	15,75	D	100 x 22 x 12 x 9,0	108,44														
M 17x1,50	15,50	D	100 x 22 x 12 x 9,0	108,44														
M 18x1,00	17,00	D	110 x 25 x 14 x 11,0	61,04	67,08		96,38											
M 18x1,25	16,75	D	110 x 25 x 14 x 11,0	75,65														
M 18x1,50	16,50	D	110 x 25 x 14 x 11,0	47,65*	52,44	64,17	62,44											
M 18x2,00	16,00	D	125 x 30 x 14 x 11,0	67,25	75,21	126,99	113,34											

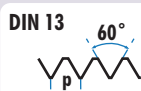
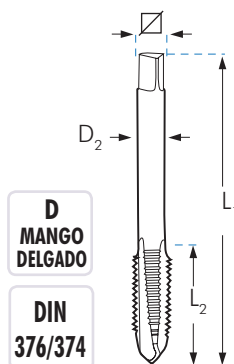
\* Disponibles también con rosca izquierda con 100% de recargo sobre los precios tarifados en rosca derecha

**MACHOS PARA ROSCAR A MÁQUINA HSSCo**
**M  
MF**

**HSSCo  
5%**
**TOL  
6H**
**D  
MANGO  
DELGADO**
**DIN  
376/374**
**Vc  
12  
m/min**

**D  
MANGO  
DELGADO**
**DIN  
376/374**

		L <sub>1</sub> x L <sub>2</sub> x D <sub>2</sub> x $\square$ mm	M1D	M2D	M3D	M4D	
			FORMA C	FORMA B	15°	35°	
			€	€	€	€	
M	18x2,50	15,50	D 125 x 30 x 14 x 11,0	51,20*	55,98	63,33	60,99
M	19x1,00	18,00	D 110 x 22 x 14 x 11,0	142,48			
M	19x1,25	17,75	D 110 x 25 x 14 x 11,0	146,52			
M	19x1,50	17,50	D 110 x 25 x 14 x 11,0	139,85			
M	19x2,00	17,00	D 110 x 25 x 14 x 11,0				
M	20x1,00	19,00	D 125 x 25 x 16 x 12,0	80,58	89,48		102,94
M	20x1,25	18,75	D 125 x 25 x 16 x 12,0	142,48			
M	20x1,50	18,50	D 125 x 25 x 16 x 12,0	53,97*	59,31	72,13	71,33
M	20x2,00	18,00	D 140 x 32 x 16 x 12,0	70,73	77,77		91,83
M	20x2,50	17,50	D 140 x 32 x 16 x 12,0	54,50*	60,44	67,59	67,60
M	21x1,00	20,00	D 125 x 25 x 16 x 12,0	206,87			
M	21x1,25	19,75	D 125 x 25 x 16 x 12,0	206,87			
M	21x1,50	19,50	D 125 x 25 x 16 x 12,0	197,56			
M	22x1,00	21,00	D 125 x 25 x 18 x 14,5	90,33	95,87		132,65
M	22x1,25	20,75	D 125 x 25 x 18 x 14,5	142,48			
M	22x1,50	20,50	D 125 x 25 x 18 x 14,5	64,96	71,46	79,12	74,44
M	22x2,00	20,00	D 140 x 32 x 18 x 14,5	90,33	99,35		132,65
M	22x2,50	19,50	D 140 x 32 x 18 x 14,5	65,95*	72,54	80,17	79,34
M	23x1,00	22,00	D 125 x 25 x 18 x 14,5	201,12			
M	23x1,50	21,50	D 125 x 25 x 18 x 14,5	201,12			
M	24x1,00	23,00	D 140 x 25 x 18 x 14,5	98,43	119,40		140,16
M	24x1,25	22,75	D 140 x 25 x 18 x 14,5	206,87			
M	24x1,50	22,50	D 140 x 28 x 18 x 14,5	79,90	87,84	105,75	100,73
M	24x2,00	22,00	D 140 x 28 x 18 x 14,5	101,94*	111,06		126,83
M	24x3,00	21,00	D 160 x 34 x 18 x 14,5	78,95*	86,41	96,62	96,43
M	25x1,00	24,00	D 140 x 28 x 18 x 14,5	190,82			
M	25x1,25	23,75	D 140 x 28 x 18 x 14,5	301,52			
M	25x1,50	23,50	D 140 x 28 x 18 x 14,5	124,31	131,57		
M	25x2,00	23,00	D 140 x 28 x 18 x 14,5	267,60	294,37		
M	26x1,00	25,00	D 140 x 28 x 18 x 14,5	148,15			
M	26x1,50	24,50	D 140 x 28 x 18 x 14,5	107,74	112,94	198,11	174,21
M	26x2,00	24,00	D 140 x 28 x 18 x 14,5	267,60	294,37		122,14
M	27x1,00	26,00	D 140 x 28 x 20 x 16,0	132,69	171,32		
M	27x1,50	25,50	D 140 x 28 x 20 x 16,0	117,64	124,62	287,92	259,61
M	27x2,00	25,00	D 140 x 28 x 20 x 16,0	145,51	153,97		

\* Disponibles también con rosca izquierda con 100% de recargo sobre los precios tarifados en rosca derecha









**MACHOS PARA ROSCAR A MÁQUINA HSSCo**

**M MF** **DIN 13** **60°** **HSSCo** **5%** **TOL** **6H** **D MANGO DELGADO** **DIN** **376/374** **Vc** **12 m/min**

Machos y Terrajas

Rosa



			L1 x L2 x D2 x  mm	M1D	M2D	M3D	M4D
				FORMA C €	FORMA B €	 15° €	 35° €
M 27x3,00	24,00	D	160 x 36 x 20 x 16	98,56*	108,08	118,88	118,65
M 28x1,00	27,00	D	140 x 28 x 20 x 16	267,60			
M 28x1,50	26,50	D	140 x 28 x 20 x 16	117,64	129,16	149,94	135,37
M 28x2,00	26,00	D	140 x 28 x 20 x 16	143,52	162,09	176,70	173,76
M 30x1,00	29,00	D	150 x 28 x 22 x 18	150,47	173,99		202,85
M 30x1,50	28,50	D	150 x 28 x 22 x 18	122,62	134,93	162,60	154,86
M 30x2,00	28,00	D	150 x 28 x 22 x 18	151,78*	161,09		222,90
M 30x3,00	27,00	D	150 x 28 x 22 x 18				
M 30x3,50	26,50	D	180 x 40 x 22 x 18	126,30*	138,86	152,37	152,05
M 32x1,00	31,00	D	150 x 28 x 22 x 18	356,82	378,88		
M 32x1,50	30,50	D	150 x 28 x 22 x 18	155,16	170,35	200,33	
M 32x2,00	30,00	D	150 x 28 x 22 x 18	190,65	291,93		
M 33x1,00	32,00	D	160 x 30 x 25 x 20	328,62			
M 33x1,50	31,50	D	160 x 30 x 25 x 20	174,81	185,40		215,79
M 33x2,00	31,00	D	160 x 30 x 25 x 20	286,50	304,01		357,36
M 33x3,50	29,50	D	180 x 40 x 25 x 20	151,78*	174,64		193,71
M 34x1,50	32,50	D	170 x 30 x 28 x 22	194,69	206,24		
M 34x2,00	32,00	D	160 x 30 x 28 x 22	409,44			
M 35x1,50	33,50	D	170 x 30 x 28 x 22	205,32	225,84		246,97
M 35x2,00	33,00	D	170 x 30 x 28 x 22	377,82	415,93		
M 36x1,50	34,50	D	170 x 30 x 28 x 22	187,48	221,64		268,29
M 36x2,00	34,00	D	170 x 30 x 28 x 22	253,22	278,54		
M 36x3,00	33,00	D	200 x 50 x 28 x 22	290,52	319,53		388,30
M 36x4,00	32,00	D	200 x 50 x 28 x 22	201,05*	213,41	247,89	237,18
M 38x1,50	36,50	D	170 x 30 x 28 x 22	199,86	225,19		
M 38x2,00	36,00	D	170 x 32 x 28 x 22	424,81	467,31		
M 39x1,50	37,50	D	170 x 32 x 32 x 24	314,06			
M 39x2,00	37,00	D	170 x 32 x 32 x 24	314,06			
M 39x3,00	36,00	D	200 x 47 x 32 x 24	410,14			
M 39x4,00	35,00	D	200 x 50 x 32 x 24	238,99	262,90		315,00
M 40x1,50	38,50	D	170 x 30 x 32 x 24	261,33	287,64		
M 40x2,00	38,00	D	170 x 30 x 32 x 24	314,89			
M 40x3,00	37,00	D	200 x 47 x 32 x 24	308,73	368,34		
M 42x1,50	40,50	D	170 x 30 x 32 x 24	285,15	294,91		
M 42x2,00	40,00	D	170 x 30 x 32 x 24	360,23			
M 42x3,00	39,00	D	200 x 45 x 32 x 24	360,23	456,50		
M 42x4,50	37,50	D	200 x 56 x 32 x 24	307,32	337,96		351,16
M 45x1,50	43,50	D	180 x 32 x 36 x 29	340,57	374,59		
M 45x2,00	43,00	D	180 x 32 x 36 x 29	417,11			
M 45x3,00	42,00	D	200 x 47 x 36 x 29	417,11			
M 45x4,50	40,50	D	220 x 58 x 36 x 29	335,70	369,25		
M 48x1,50	46,50	D	190 x 32 x 36 x 29	335,70			
M 48x2,00	46,00	D	190 x 32 x 36 x 29	542,43			
M 48x3,00	45,00	D	220 x 52 x 36 x 29	505,46			
M 48x5,00	43,00	D	250 x 65 x 36 x 29	412,82	454,07		
M 50x1,50	48,50	D	190 x 32 x 36 x 29	406,87			
M 52x1,50	50,50	D	190 x 32 x 40 x 32	397,47			
M 52x2,00	50,00	D	190 x 32 x 40 x 32	629,00			
M 52x3,00	49,00	D	225 x 50 x 40 x 32	646,44			
M 52x5,00	47,00	D	250 x 65 x 40 x 32	422,78	523,11		

\* Disponibles también con rosca izquierda con 100% de recargo sobre los precios tarifados en rosca derecha

## MACHOS PARA ROSCAR A MÁQUINA HSSCo

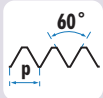
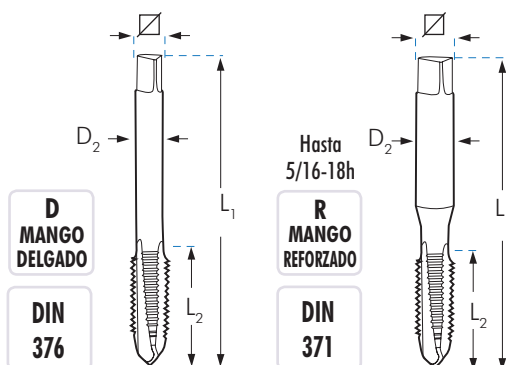
UNC

HSSCo  
5%TOL  
2BVc  
12 m/min

	D <sub>1</sub> mm		L <sub>1</sub> x L <sub>2</sub> x D <sub>2</sub> x ∇ mm	MTR	M2R	M4R
				FORMA C	FORMA B	35°
				€	€	€
UNC n° 4-40h	2,84	2,25	R 56 x 11 x 3,5 x 2,7	24,19	28,76	32,82
UNC n° 5-40h	3,17	2,60	R 56 x 11 x 3,5 x 2,7	25,07	30,08	32,82
UNC n° 6-32h	3,50	2,75	R 56 x 12 x 4,0 x 3,0	23,86	28,67	32,68
UNC n° 8-32h	4,17	3,50	R 63 x 13 x 4,5 x 3,4	23,86	28,67	31,25
UNC n° 10-24h	4,83	3,90	R 70 x 15 x 6,0 x 4,9	25,07	30,08	34,33
UNC n° 12-24h	5,49	4,50	R 80 x 16 x 6,0 x 4,9	26,30	30,08	31,51
UNC 1/4-20h	6,35	5,10	R 80 x 17 x 7,0 x 5,5	23,43	25,55	29,48
UNC 5/16-18h	7,94	6,60	R 90 x 20 x 8,0 x 6,2	26,52	29,24	33,29

MANGO DELGADO				M1D	M2D	M4D
UNC 3/8-16h	9,52	8,00	D 100 x 22 x 7,0 x 5,5	30,24	31,71	35,63
UNC 7/16-14h	11,11	9,40	D 100 x 22 x 8,0 x 6,2	41,61	41,75	52,22
UNC 1/2-13h	12,70	10,75	D 110 x 24 x 9,0 x 7,0	45,16	50,04	57,11
UNC 9/16-12h	14,28	12,20	D 110 x 26 x 11,0 x 9,0	62,08	68,16	77,54
UNC 5/8-11h	15,87	13,50	D 110 x 27 x 12,0 x 9,0	60,31	66,38	75,41
UNC 3/4-10h	19,05	16,50	D 125 x 30 x 14,0 x 11,0	79,85	87,78	99,88
UNC 7/8-9h	22,22	19,50	D 140 x 32 x 18,0 x 14,5	105,07	115,43	156,28
UNC 1"-8h	25,40	22,25	D 160 x 36 x 18,0 x 14,5	138,83	151,66	196,05
UNC 1.1/8-7h	28,57	25,00	D 180 x 40 x 22,0 x 18,0	181,34		219,05
UNC 1.1/4-7h	31,75	28,00	D 180 x 40 x 22,0 x 18,0	212,55		280,23
UNC 1.3/8-6h	34,92	30,75	D 200 x 50 x 28,0 x 22,0	317,04		
UNC 1.1/2-6h	38,10	34,00	D 200 x 50 x 32,0 x 24,0	360,04		

MACHOS PARA ROSCAR A MÁQUINA HSSCo

UNF

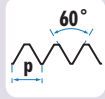

HSSCo  
5%

TOL  
2B

Vc  
12 m/min

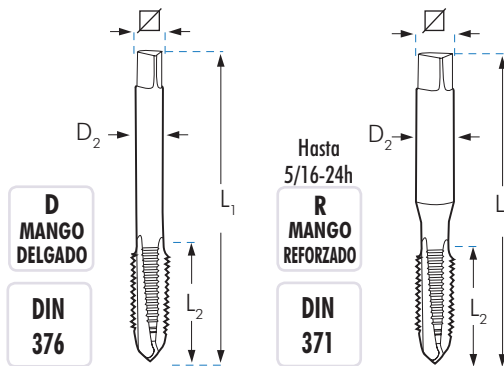

UNF nº	D1 mm	D2 mm	L1 x L2 x D2 x mm	M1R	M2R	M4R
				FORMA C	FORMA B	FORMA 35°
				€	€	€
UNF nº 1-72h	1,85	1,50	R 40 x 8 x 2,5 x 2,1	25,32	27,57	34,60
UNF nº 2-64h	2,18	1,85	R 45 x 9 x 2,8 x 2,1	25,32	27,57	34,60
UNF nº 3-56h	2,51	2,15	R 50 x 9 x 2,8 x 2,1	24,22	29,00	34,34
UNF nº 4-48h	2,84	2,35	R 56 x 11 x 3,5 x 2,7	24,22	29,00	34,34
UNF nº 5-44h	3,17	2,70	R 56 x 11 x 3,5 x 2,7	24,22	29,00	34,34
UNF nº 6-40h	3,50	2,95	R 56 x 12 x 4,0 x 3,0	25,32	30,34	34,60
UNF nº 8-36h	4,17	3,50	R 63 x 13 x 4,5 x 3,4	20,45	21,91	25,56
UNF nº 10-32h	4,83	4,10	R 70 x 15 x 6,0 x 4,9	22,87	25,21	29,47

MANGO DELGADO				M1D	M2D	M4D	
UNF	h	D1 mm	D2 mm	D			
UNF	3/8-24h	9,52	8,50	D 90 x 16 x 7,0 x 5,5	25,04	28,96	36,87
UNF	7/16-20h	11,11	9,90	D 100 x 22 x 8,0 x 6,2	30,89	35,80	47,26
UNF	1/2-20h	12,70	11,50	D 100 x 22 x 9,0 x 7,0	32,89	38,07	50,28
UNF	9/16-18h	14,29	12,90	D 100 x 22 x 11,0 x 9,0	40,41	46,79	62,26
UNF	5/8-18h	15,87	14,50	D 100 x 22 x 12,0 x 9,0	45,49	52,63	69,57
UNF	3/4-16h	19,05	17,50	D 110 x 25 x 14,0 x 11,0	58,21	67,41	88,98
UNF	7/8-14h	22,22	20,40	D 125 x 25 x 18,0 x 14,5	73,20	91,57	136,11
UNF	1"-12h	25,40	23,25	D 140 x 28 x 18,0 x 14,5	110,18	119,97	160,20
UNS	1"-14h	25,40	23,60	D 140 x 28 x 18,0 x 14,5	110,67	123,42	160,20
UNF	1.1/8-12h	28,57	26,50	D 150 x 28 x 22,0 x 18,0	167,88		
UNF	1.1/4-12h	31,75	29,50	D 150 x 28 x 22,0 x 18,0	212,15		
UNF	1.1/2-12h	38,10	36,00	D 170 x 30 x 32,0 x 24,0	356,06		

## MACHOS PARA ROSCAR A MÁQUINA HSSCo

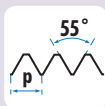
BSP  
(GAS)HSSCo  
5%TOL  
ISO 228

INOX

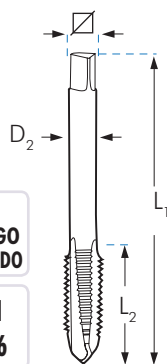
Vc  
12 m/minVc  
6 m/minD  
MANGO  
DELGADODIN  
5156

Forma	D1 mm	D	L1 x L2 x D2 x $\nabla$ mm	M1D		M2D		M3D		M4D		M2DX		M4DX	
				FORMA C	€	FORMA B	€	FORMA A 15°	€	FORMA B 35°	€	FORMA B	€	FORMA A 35°	€
G 1/8-28h.	9,728	8,80	D 90 x 16 x 7 x 5,5	32,02*	36,58	37,47	38,83					54,48	53,92		
G 1/4-19h.	13,157	11,80	D 100 x 22 x 11 x 9,0	44,41*	48,89	53,81	55,76					73,40	78,56		
G 3/8-19h.	16,662	15,25	D 100 x 22 x 12 x 9,0	53,17*	58,50	64,27	66,59					87,08	92,33		
G 1/2-14h.	20,955	19,00	D 125 x 25 x 16 x 12,0	67,20*	73,94	81,07	83,98					107,82	116,54		
G 5/8-14h.	22,911	21,00	D 125 x 25 x 18 x 14,5	83,74*	87,82	100,93	100,00								
G 3/4-14h.	26,441	24,50	D 140 x 28 x 20 x 16,0	105,18	115,76	126,89	131,47					162,91	179,73		
G 7/8-14h.	30,201	28,25	D 150 x 28 x 22 x 18,0	141,39	148,74	170,66	169,07								
G 1"-11h.	33,249	30,75	D 160 x 30 x 25 x 20,0	163,26	179,55	194,84	201,89								
G 1.1/8-11h.	37,897	35,50	D 170 x 30 x 28 x 22,0	260,70	284,37		312,32								
G 1.1/4-11h.	41,910	39,50	D 170 x 30 x 32 x 24,0	305,90	321,85		356,30								
G 1.3/8-11h.	44,323	42,00	D 180 x 32 x 36 x 29,0	365,78			494,92								
G 1.1/2-11h.	47,803	45,25	D 190 x 32 x 36 x 29,0	487,77	679,97		644,16								
G 1.3/4-11h.	53,746	51,25	D 190 x 32 x 40 x 32,0	579,77	670,74										
G 2"-11h.	59,614	57,00	D 220 x 36 x 45 x 35,0	739,44	736,02										

\* Disponibles también con rosca izquierda con 100% de recargo sobre los precios tarifados en rosca derecha

BSF

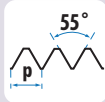
HSSCo  
5%TOL  
ISO 228Vc  
12 m/minD  
MANGO  
DELGADODIN  
5156

Forma	D1 mm	D	L1 x L2 x D2 x $\nabla$ mm	M1D	
				FORMA C	€
BSF 3/16-32h.	4,762	4,00	D 70 x 16 x 3,5 x 2,7		73,26
BSF 1/4-26h.	6,350	5,20	D 80 x 17 x 4,5 x 3,4		32,06
BSF 5/16-22h.	7,938	6,60	D 90 x 20 x 6,0 x 4,9		38,07
BSF 3/8-20h.	9,525	8,10	D 100 x 22 x 7,0 x 5,5		40,02
BSF 7/16-18h.	11,113	9,50	D 100 x 22 x 8,0 x 6,2		53,93
BSF 1/2-16h.	12,700	11,00	D 110 x 24 x 9,0 x 7,0		61,04
BSF 9/16-16h.	14,287	12,50	D 110 x 25 x 11,0 x 9,0		64,60
BSF 5/8-14h.	15,876	14,00	D 110 x 27 x 12,0 x 9,0		86,10
BSF 3/4-12h.	19,051	16,50	D 125 x 30 x 14,0 x 11,0		101,92
BSF 7/8-11h.	22,226	19,50	D 140 x 32 x 18,0 x 14,5		141,65
BSF 1"-10h.	25,400	22,50	D 160 x 36 x 18,0 x 14,5		164,66



MACHOS PARA ROSCAR A MÁQUINA HSSCo

BSW

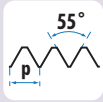

HSSCo  
5%

TOL  
Clase 2

Vc  
12 m/min

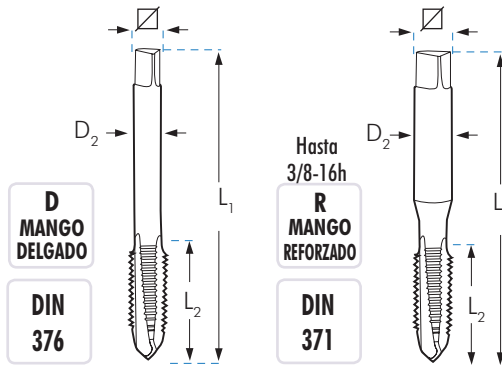

Icono	D1 mm	D2 mm	L1 x L2 x D2 x $\angle$ mm	M1R	M2R	M3R	M4R
				FORMA C	FORMA B	15°	35°
				€	€	€	€
W 3/32-48h.	2,38	1,80	R 50 x 9 x 2,8 x 2,1	22,25	23,75		
W 1/8-40h.	3,17	2,55	R 56 x 11 x 3,5 x 2,7	18,57*	20,52	24,23	23,31
W 5/32-32h.	3,97	3,10	R 63 x 13 x 4,5 x 3,4	18,57	20,52	24,23	23,31
W 3/16-24h.	4,76	3,60	R 70 x 15 x 6,0 x 4,9	20,60	20,52	24,23	23,31
W 7/32-24h.	5,56	4,40	R 80 x 16 x 6,0 x 4,9	28,19	29,80		
W 1/4-20h.	6,35	5,10	R 80 x 17 x 7,0 x 5,5	19,83	23,31	27,50	28,49
W 5/16-18h.	7,94	6,50	R 90 x 20 x 8,0 x 6,2	22,24	29,40	32,09	32,04
W 3/8-16h.	9,52	7,90	R 100 x 22 x 10,0 x 8,0	24,89	32,49	35,67	35,61

MANGO DELGADO				M1D	M2D	M3D	M4D
W 7/16-14h.	11,11	9,25	D 100 x 22 x 8,0 x 6,2	34,61	35,78	44,96	45,28
W 1/2-12h.	12,70	10,50	D 110 x 24 x 9,0 x 7,0	33,19	37,31	43,08	43,39
W 9/16-12h.	14,29	12,00	D 110 x 26 x 11,0 x 9,0	47,58	49,41	61,78	62,22
W 5/8-11h.	15,87	13,40	D 110 x 27 x 12,0 x 9,0	45,05	46,68	58,42	58,83
W 11/16-11h.	17,46	15,25	D 110 x 27 x 12,0 x 9,0				
W 3/4-10h.	19,05	16,50	D 125 x 30 x 14,0 x 11,0	63,05	65,44	78,27	78,83
W 7/8-9h.	22,22	19,25	D 140 x 32 x 18,0 x 14,5	81,66	84,68	105,95	102,03
W 1"-8h.	25,40	21,75	D 160 x 36 x 18,0 x 14,5	102,63	106,43	132,96	133,91
W 1.1/8-7h.	28,57	24,75	D 180 x 40 x 22,0 x 18,0	139,19	158,59	190,70	
W 1.1/4-7h.	31,75	27,75	D 180 x 40 x 22,0 x 18,0	202,20	230,44		
W 1.3/8-6h.	34,92	30,50	D 200 x 50 x 28,0 x 22,0	332,35	378,42		
W 1.1/2-6h.	38,10	33,50	D 200 x 50 x 32,0 x 24,0	360,74	411,12		
W 1.5/8-5h.	41,27	46,50	D 220 x 65 x 32,0 x 24,0	503,52	573,87		
W 1.3/4-5h.	44,45	39,00	D 220 x 58 x 36,0 x 29,0	539,33	619,10		
W 1.7/8-4,5h.	47,62	42,00	D 250 x 75 x 36,0 x 29,0	625,37	686,33		
W 2"-4,5h.	50,80	44,50	D 250 x 65 x 40,0 x 32,0	771,90			

\* Disponibles también con rosca izquierda con 100% de recargo sobre los precios tarifados en rosca derecha

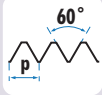
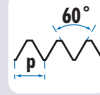
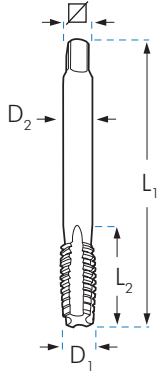
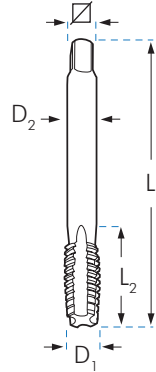
**MACHOS PARA ROSCAR A MÁQUINA HSSCo**
**UNJC**

**HSSCo**  
**5%**
**TOL**  
**3B**
**UNJF**

**HSSCo**  
**5%**
**TOL**  
**3B**
**Vc**  
**12 m/min**

**Vc**  
**12 m/min**

Icon	D1 mm	D2	R	L1 x L2 x D2 x $\nabla$ mm	MIR
					FORMA C €
UNJC nº 4-40h	2,84	2,25	R	56 x 11 x 3,5 x 2,7	36,74
UNJC nº 5-40h	3,17	2,60	R	56 x 11 x 3,5 x 2,7	36,74
UNJC nº 6-32h	3,50	2,75	R	56 x 12 x 4,0 x 3,0	36,74
UNJC nº 8-32h	4,17	3,50	R	63 x 13 x 4,5 x 3,4	36,74
UNJC nº10-24h	4,83	3,90	R	70 x 15 x 6,0 x 4,9	36,74
UNJC nº12-24h	5,49	4,50	R	80 x 16 x 6,0 x 4,9	38,54
UNJC 1/4-20h	6,35	5,10	R	80 x 17 x 7,0 x 5,5	34,28
UNJC 5/16-18h	7,94	6,60	R	90 x 20 x 8,0 x 6,2	38,79
UNJC 3/8-16h	9,52	8,00	R	100 x 22 x 8,0 x 6,2	44,23

Icon	D1 mm	D2	R	L1 x L2 x D2 x $\nabla$ mm	MIR
					FORMA C €
UNJF nº 4-48h	2,84	2,35	R	56 x 11 x 3,5 x 2,7	40,30
UNJF nº 5-44h	3,17	2,70	R	56 x 11 x 3,5 x 2,7	40,30
UNJF nº 6-40h	3,50	2,95	R	56 x 12 x 4,0 x 3,0	40,30
UNJF nº 8-36h	4,17	3,50	R	63 x 13 x 4,5 x 3,4	40,30
UNJF nº10-32h	4,83	4,10	R	70 x 15 x 6,0 x 4,9	40,30
UNJF nº12-28h	5,49	4,60	R	80 x 16 x 6,0 x 4,9	40,30
UNJF 1/4-28h	6,35	5,50	R	80 x 17 x 7,0 x 5,5	31,29
UNJF 5/16-24h	7,94	6,90	R	90 x 20 x 8,0 x 6,2	34,99
UNJF 3/8-24h	9,52	8,50	R	90 x 16 x 7,0 x 6,2	38,31

MANGO DELGADO PASOS NORMALES				MID
UNJC 7/16-14h	11,11	9,40	D 110 x 24 x 9,0 x 7,0	60,99
UNJC 1/2-13h	12,70	10,75	D 110 x 26 x 11,0 x 9,0	66,20
UNJC 9/16-12h	14,28	12,20	D 110 x 27 x 12,0 x 9,0	90,99
UNJC 5/8-11h	15,87	13,50	D 110 x 27 x 12,0 x 9,0	93,27
UNJC 3/4-10h	19,05	16,50	D 125 x 30 x 14,0 x 11,0	117,03
UNJC 7/8-9h	22,22	19,50	D 140 x 32 x 18,0 x 14,5	153,99
UNJC 1"-8h	25,40	22,25	D 160 x 36 x 18,0 x 14,5	203,45

MANGO DELGADO PASOS NORMALES				MID
UNJF 7/16-20h	11,11	9,90	D 100 x 22 x 8,0 x 6,2	52,61
UNJF 1/2-20h	12,70	11,50	D 100 x 22 x 9,0 x 7,0	56,03
UNJF 9/16-18h	14,29	12,90	D 100 x 22 x 11,0 x 9,0	68,84
UNJF 5/8-18h	15,87	14,50	D 100 x 22 x 12,0 x 9,0	77,50
UNJF 3/4-16h	19,05	17,50	D 110 x 25 x 14,0 x 11,0	99,15
UNJF 7/8-14h	22,22	20,40	D 125 x 25 x 18,0 x 14,5	124,68
UNJF 1"-12h	25,40	23,25	D 140 x 28 x 18,0 x 14,5	139,01

**MACHOS PARA ROSCAR A MÁQUINA HSSCo**

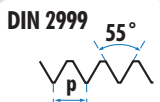
**BSPB**  **HSSCo 5%** **DIN 374** **FORMA C**

**BSPT**  **HSSCo 5%** **DIN 5156** **FORMA C**

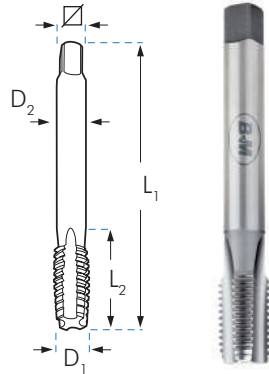

ROSCA CILÍNDRICA INGLESA PARA TUBO

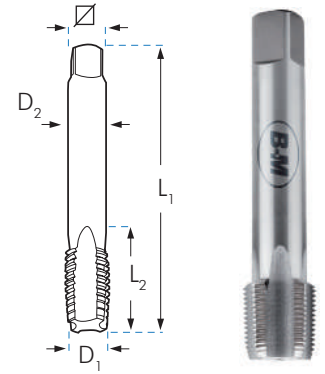

ROSCA CÓNICA INGLESA PARA TUBO



	D1 mm	L1 x L2 x D2 x $\nabla$ mm	MTD	€
Rp 1/16-28h.	7,72	D 90 x 16 x 6 x 4,9		
Rp 1/8-28h.	9,73	D 90 x 16 x 7 x 5,5		47,78
Rp 1/4-19h.	13,16	D 100 x 22 x 11 x 9,0		66,00
Rp 3/8-19h.	16,66	D 100 x 22 x 12 x 9,0		79,03
Rp 1/2-14h.	20,95	D 125 x 25 x 16 x 12,0		99,88
Rp 3/4-14h.	26,44	D 140 x 28 x 20 x 16,0		156,40
Rp 1"-11h.	33,25	D 160 x 30 x 25 x 20,0		242,66
Rp 1.1/4-11h.	41,91	D 170 x 30 x 32 x 24,0		
Rp 1.1/2-11h.	46,80	D 190 x 32 x 36 x 29,0		
Rp 2"-11h.	59,61	D 220 x 36 x 45 x 35,0		

	D1 mm		L1 x L2 x D2 x $\nabla$ mm	MTD	€
Rc 1/16-28h.	7,72		D 90 x 14 x 6 x 4		
Rc 1/8-28h.	9,73	8,30	D 90 x 15 x 7 x 5		48,89
Rc 1/4-19h.	13,16	11,00	D 100 x 19 x 11 x 9		70,31
Rc 3/8-19h.	16,66	14,50	D 100 x 21 x 12 x 9		97,72
Rc 1/2-14h.	20,95	18,10	D 125 x 26 x 16 x 12		135,77
Rc 5/8-14h.	22,91	21,00	D 140 x 36 x 18 x 19		219,02
Rc 3/4-14h.	26,44	23,50	D 140 x 28 x 20 x 16		211,76
Rc 7/8-14h.	30,20	28,25	D 160 x 36 x 22 x 18		368,49
Rc 1"-11h.	33,25	29,60	D 160 x 33 x 25 x 20		303,50

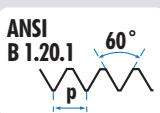
**NPS (M)**  **HSSCo 5%** **DIN 374** **FORMA C**

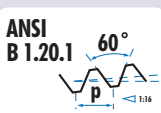

**NPT**  **HSSCo 5%** **DIN 374** **FORMA C**

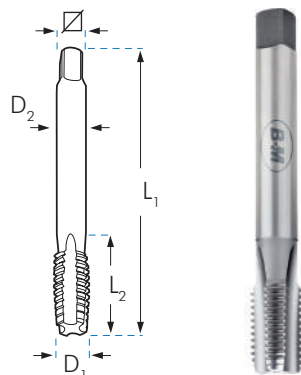

ROSCA CILÍNDRICA AMERICANA PARA TUBO

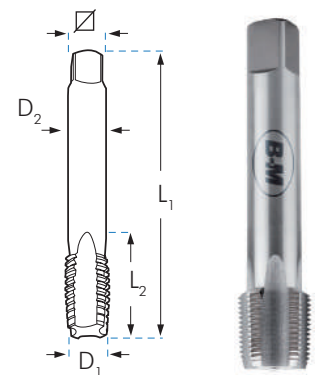

ROSCA CÓNICA AMERICANA PARA TUBO



	D1 mm		L1 x L2 x D2 x $\nabla$ mm	MTD	€
NPS 1/8-27h.	10,20	8,90	D 90 x 16 x 7 x 5,5		123,08
NPS 1/4-18h.	13,60	11,70	D 100 x 22 x 11 x 9,0		176,15
NPS 3/8-18h.	17,00	15,00	D 100 x 22 x 12 x 9,0		241,56
NPS 1/2-14h.	21,20	18,60	D 125 x 25 x 16 x 12,0		331,24
NPS 3/4-14h.	26,55	24,00	D 140 x 28 x 20 x 16,0		489,67
NPS 1"-11,5 h.	33,20	30,00	D 160 x 30 x 25 x 20,0		633,24
NPS 1.1/4-11,5h.	41,60		D 170 x 30 x 32 x 24,0		
NPS 1.1/2-11,5h.	47,68		D 190 x 32 x 36 x 29,0		
NPS 2"-11,5h.	59,71		D 220 x 36 x 45 x 35,0		

	D1 mm		L1 x L2 x D2 x $\nabla$ mm	MTD	€
NPT 1/16-27h.	7,89	6,2	D 90 x 14 x 6 x 5		42,82
NPT 1/8-27h.	10,24	8,5	D 90 x 15 x 8 x 6		44,78
NPT 1/4-18h.	13,62	11,0	D 100 x 19 x 11 x 9		57,83
NPT 3/8-18h.	17,05	14,5	D 100 x 21 x 12 x 9		74,34
NPT 1/2-14h.	21,22	17,8	D 125 x 26 x 16 x 12		96,71
NPT 3/4-14h.	26,57	23,0	D 140 x 28 x 20 x 16		149,84
NPT 1"-11,5h.	33,23	29,0	D 160 x 33 x 25 x 20		194,75
NPT 1.1/4-11,5h.	41,98	37,5	D 170 x 36 x 32 x 24		265,91
NPT 1.1/2-11,5h.	48,05	44,0	D 190 x 37 x 36 x 29		418,70
NPT 2"-11,5h.	60,09	56,0	D 220 x 41 x 45 x 35		656,77

## MACHOS PARA ROSCAR A MÁQUINA HSSCo

NPSF

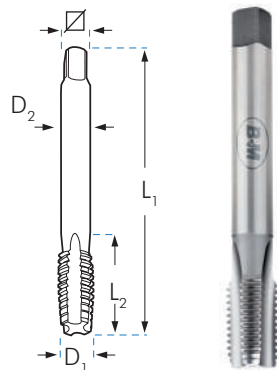
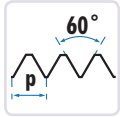
HSSCo  
5%DIN  
374FORMA  
CROSCA PARA TUBO  
AMERICANA CILÍNDRICA

NPTF

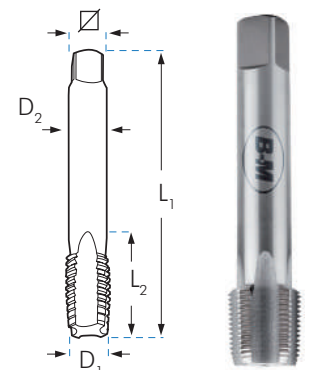
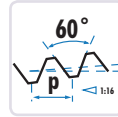
HSSCo  
5%DIN  
374FORMA  
CROSCA PARA TUBO  
AMERICANA CÓNICA ESTANCA

		MID			
		D1 mm		L1 x L2 x D2 x $\nabla$ mm	€
NPSF	1/8-27h.	10,05	8,75	D 90 x 16 x 7 x 5,5	154,17
NPSF	1/4-18h.	13,33	11,30	D 100 x 22 x 11 x 9,0	212,50
NPSF	3/8-18h.	16,78	14,70	D 100 x 22 x 12 x 9,0	302,30
NPSF	1/2-14h.	20,87	18,20	D 125 x 25 x 16 x 12,0	376,98
NPSF	3/4-14h.	26,23	23,50	D 140 x 28 x 20 x 16,0	616,98
NPSF	1"-11,5h.	32,81	29,50	D 160 x 30 x 25 x 20,0	

		MID			
		D1 mm		L1 x L2 x D2 x $\nabla$ mm	€
NPTF	1/16-27h.	7,87	6,20	D 90 x 14 x 12,0 x 6	
NPTF	1/8-27h.	10,22	8,50	D 90 x 15 x 12,0 x 7	104,16
NPTF	1/4-18h.	13,58	11,00	D 100 x 21 x 17,5 x 11	146,13
NPTF	3/8-18h.	17,02	14,50	D 110 x 21 x 17,6 x 12	187,73
NPTF	1/2-14h.	21,21	17,80	D 140 x 27 x 22,8 x 16	244,39
NPTF	3/4-14h.	26,56	23,00	D 140 x 27 x 23,0 x 20	378,60

MF

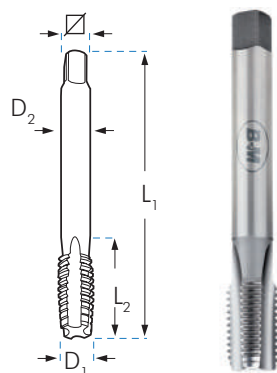
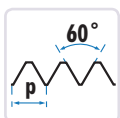
HSSCo  
5%TOL  
6HFORMA  
CDIN  
374ROSCA MÉTRICA FINA PARA  
TUBO DE CONDUCCIÓN  
ELÉCTRICA EN 60423

PG

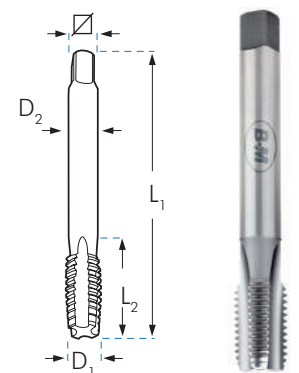
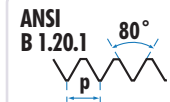
HSSCo  
5%DIN  
40430FORMA  
CROSCA PARA TUBO  
DE CONDUCCIÓN  
ELÉCTRICA

		MID			
		D1 mm		L1 x L2 x D2 x $\nabla$ mm	€
MF	12 x 1,50	12	10,5	D 100 x 22 x 9 x 7,0	25,56
MF	16 x 1,50	16	14,5	D 100 x 22 x 12 x 9,0	35,99
MF	20 x 1,50	20	18,5	D 125 x 25 x 16 x 12,0	53,97
MF	25 x 1,50	25	23,5	D 140 x 28 x 18 x 14,5	124,31
MF	32 x 1,50	32	30,5	D 150 x 28 x 22 x 18,0	155,16
MF	40 x 1,50	40	38,5	D 170 x 30 x 32 x 24,0	261,33
MF	50 x 1,50	50	48,5	D 190 x 32 x 36 x 29,0	406,87
MF	63 x 1,50	63	61,5	D 275 x 36 x 50 x 39,0	

		MID			
		D1 mm		L1 x L2 x D2 x $\nabla$ mm	€
PG	7 - 20h.	12,5	11,50	D 100 x 22 x 9 x 7,0	45,71
PG	9 - 18h.	15,2	14,00	D 100 x 22 x 12 x 9,0	63,30
PG	11 - 18h.	18,6	17,25	D 110 x 25 x 14 x 11,0	82,36
PG	13,5 - 18h.	20,4	19,00	D 125 x 25 x 16 x 12,0	92,49
PG	16 - 18h.	22,5	21,25	D 125 x 25 x 18 x 14,5	108,85
PG	21 - 16h.	28,3	27,00	D 150 x 28 x 22 x 18,0	172,80
PG	29 - 16h.	37,0	35,50	D 170 x 30 x 28 x 22,0	292,12
PG	36 - 16h.	47,0	45,50	D 190 x 32 x 36 x 29,0	474,42
PG	42 - 16h.	54,0	52,50	D 190 x 32 x 40 x 32,0	753,46
PG	48 - 16h.	59,3	58,00	D 220 x 36 x 45 x 35,0	918,53



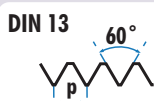
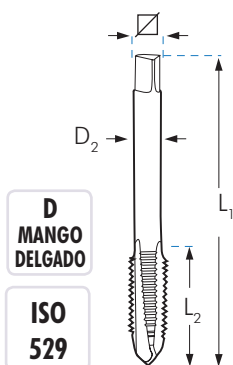

**MACHOS MÁQUINA MÉTRICA NORMA ISO 529**
**M**  
**MF**

**HSSCo**  
**5%**
**ISO**  
**529**
**TOL**  
**6H**

**D**  
**MANGO**  
**DELGADO**  
**ISO**  
**529**

**R**  
**MANGO**  
**REFORZADO**  
**ISO**  
**529**

		L <sub>1</sub> x L <sub>2</sub> x D <sub>2</sub> x  mm	M1RISO	M2RISO	M4RISO	M5RISO
			FORMA C	FORMA B	35°	DIENTE ALTERNO
			€	€	€	Al
M 3x0,50	2,50	R 48 x 11 x 3,15 x 2,50	7,71	8,04	9,68	11,51
M 4x0,70	3,30	R 53 x 13 x 4,00 x 3,15	7,71	8,04	9,68	11,51
M 5x0,80	4,20	R 58 x 16 x 5,00 x 4,00	7,71	8,04	9,68	11,51
M 6x1,00	5,00	R 66 x 19 x 6,30 x 5,00	7,71	8,04	9,89	11,51
M 7x1,00	6,00	R 66 x 19 x 7,10 x 5,60		11,43	13,12	
M 8x1,00	7,00	R 69 x 19 x 8,00 x 6,30		15,77	16,19	
M 8x1,25	6,75	R 72 x 22 x 8,00 x 6,30	10,30	10,73	11,09	12,58
M 9x1,25	7,75	R 76 x 20 x 10,00 x 8,00		17,07	19,49	
M 10x1,00	9,00	R 76 x 20 x 10,00 x 8,00		18,09	19,76	
M 10x1,25	8,80	R 76 x 20 x 10,00 x 8,00		21,63	22,33	
M 10x1,50	8,50	R 80 x 24 x 10,00 x 8,00	13,10	13,65	14,30	15,87
<b>MANGO DELGADO</b>			M1DISO	M2DISO	M4DISO	M5DISO
M 12x1,00	11,00	D 84 x 24 x 9,00 x 7,10		24,92	25,54	
M 12x1,25	10,75	D 84 x 24 x 9,00 x 7,10		24,48	25,35	
M 12x1,50	10,50	D 89 x 29 x 9,00 x 7,10		21,84	23,52	
M 12x1,75	10,20	D 89 x 29 x 9,00 x 7,10	16,84	17,54	18,58	23,74
M 14x1,00	13,00	D 90 x 25 x 11,20 x 9,00		31,22	38,83	
M 14x1,25	12,80	D 90 x 25 x 11,20 x 9,00		26,36	33,01	
M 14x1,50	12,50	D 95 x 30 x 12,50 x 9,00		23,16	26,03	
M 14x2,00	12,00	D 95 x 30 x 11,20 x 9,00	20,13	20,97	25,39	
M 16x1,00	15,00	D 95 x 25 x 12,50 x 10,00		39,72	51,11	
M 16x1,25	14,75	D 102 x 32 x 12,50 x 10,00		44,04	56,68	
M 16x1,50	14,50	D 102 x 32 x 14,00 x 10,00		27,80	31,15	
M 16x2,00	14,00	D 102 x 32 x 12,50 x 10,00	25,00	26,04	29,45	
M 18x1,50	16,50	D 104 x 29 x 14,00 x 11,20		36,73	50,19	
M 18x2,50	15,50	D 112 x 37 x 14,00 x 11,20	37,64	39,21	49,02	
M 20x1,50	18,50	D 104 x 29 x 14,00 x 11,20		47,26	57,81	
M 20x2,50	17,50	D 112 x 37 x 14,00 x 11,20	42,08	43,83	54,78	
M 22x2,50	19,50	D 118 x 38 x 16,00 x 12,50	48,65	50,68	63,35	
M 24x3,00	21,00	D 130 x 45 x 18,00 x 14,00	54,96	57,25	71,56	
M 27x3,00	24,00	D 135 x 45 x 20,00 x 16,00	67,68	70,50	88,13	
M 30x3,50	26,50	D 138 x 48 x 20,00 x 16,00	100,56	104,75	130,93	

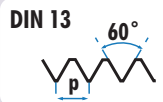
MACHOS MÁQUINA CORTOS DIN 352

M  
MF



HSS

HSSCo  
5%

DIN  
352

TOL  
6H

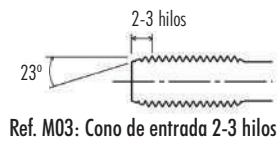

Ref. M03: Cono de entrada 2-3 hilos

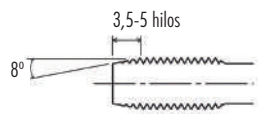

Ref. M02AT: Cono de entrada 3,5-5 hilos

D  
MANGO  
DELGADO

DIN  
352

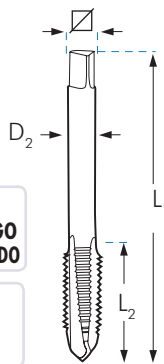

Icono	Icono	L1 x L2 x D2 x $\square$ mm	M03	M02AT	M03X	M02DIN	M04DIN
			HSS €	ALtura TERMINADA HSS €	INOX HSSCo €	FORMA B HSS €	35° HSS €
M 3x0,50	2,50	D 40 x 11 x 3,50 x 2,70	6,94	9,37	11,73	8,84	10,65
M 4x0,70	3,30	D 45 x 13 x 4,50 x 3,40	6,94	9,36	11,73	8,84	10,65
M 5x0,80	4,20	D 50 x 16 x 6,00 x 4,90	7,49	10,02	12,21	8,84	10,65
M 6x1,00	5,00	D 50 x 19 x 6,00 x 4,90	7,49	10,02	12,17	8,84	10,88
M 7x1,00	6,00	D 50 x 19 x 6,00 x 4,90	9,03				
M 8x1,00	7,00	D 56 x 18 x 6,00 x 4,90	12,50				
M 8x1,25	6,75	D 56 x 22 x 6,00 x 4,90	9,03	12,19	14,17	11,80	13,19
M 9x1,25	7,75	D 63 x 18 x 7,00 x 5,50	14,79				
M 10x1,00	9,00	D 63 x 18 x 7,00 x 5,50	13,38				
M 10x1,25	8,80	D 70 x 24 x 7,00 x 5,50	13,57				
M 10x1,50	8,50	D 70 x 24 x 7,00 x 5,50	11,13	15,02	18,23	15,01	16,62
M 12x1,00	11,00	D 70 x 20 x 9,00 x 7,00	23,74				
M 12x1,25	10,75	D 70 x 20 x 9,00 x 7,00	23,66				
M 12x1,50	10,50	D 70 x 20 x 9,00 x 7,00	20,17				
M 12x1,75	10,20	D 75 x 29 x 9,00 x 7,00	15,81	21,15	26,10	19,30	21,64
M 14x1,00	13,00	D 70 x 20 x 11,00 x 9,00	37,00				
M 14x1,25	12,80	D 70 x 20 x 11,00 x 9,00	28,89				
M 14x1,50	12,50	D 70 x 20 x 11,00 x 9,00	22,47				
M 14x2,00	12,00	D 80 x 30 x 11,00 x 9,00	17,49	23,39	28,90	23,07	27,93
M 16x1,00	15,00	D 70 x 20 x 12,00 x 9,00	49,08				
M 16x1,25	14,75	D 70 x 20 x 12,00 x 9,00	51,66				
M 16x1,50	14,50	D 70 x 20 x 12,00 x 9,00	27,96				
M 16x2,00	14,00	D 80 x 32 x 12,00 x 9,00	25,26		39,61	28,65	32,39
M 18x1,50	16,50	D 80 x 22 x 14,00 x 11,00	36,84				
M 18x2,50	15,50	D 95 x 40 x 14,00 x 11,00	33,34		54,10	43,13	53,92
M 20x1,50	18,50	D 80 x 22 x 16,00 x 12,00	46,13				
M 20x2,50	17,50	D 95 x 40 x 16,00 x 12,00	37,40		60,05	48,21	60,26
M 22x2,50	19,50	D 100 x 40 x 18,00 x 14,50	48,87			55,74	69,69
M 24x3,00	21,00	D 110 x 50 x 18,00 x 14,50	59,42			62,98	78,72
M 27x3,00	24,00	D 110 x 50 x 20,00 x 16,00	73,72			81,29	89,24
M 30x3,50	26,50	D 125 x 50 x 22,00 x 18,00	95,75			104,45	114,36

MACHOS DE MÁQUINA Y COJINETES SERIE *Plus* Y *Super Plus*

Machos y Terrajas

Rosa

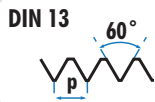

**TOL**  
**6H**

PARA TRABAJOS DE ALTA PRODUCCIÓN  
FABRICADOS EN ACERO SINTERIZADO

**DIN**  
**22568**

**TOL**  
**6g**



ROSCA LAPEADA Y ROMPEVIRUTAS

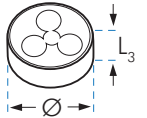

*Plus*      *Plus TiN*      *Plus LUBE*      *Super Plus ALTiN*

CALIDAD	<i>Plus</i>		<i>Plus TiN</i>		<i>Plus LUBE</i>		<i>Super Plus ALTiN</i>		CSP			
	M2RP	M4RP	M2RT	M4RT	M2RHL	M4RHL	M2RSP	M4RSP				
MATERIAL	HSS PM	HSS PM	HSSCo 5%	HSSCo 5%	HSS PM	HSS PM	HSS V3	HSS V3		HSS		
ACABADO	BRILLANTE	BRILLANTE	TiN	TiN	HARD LUBE	HARD LUBE	ALTiN	ALTiN		BRILLANTE		
ÁNGULO DE HÉLICE	FORMA B	FORMA B 35°	FORMA B	FORMA B 35°	FORMA B	FORMA B 35°	FORMA B	FORMA B 41°				
	L1 x L2 x D2 x								Ø x L3			
	mm		€	€	€	€	€	€	mm	€		
M 3x0,50	2,50 R	56 x 11 x 3,5 x 2,7	15,23	18,82	20,50	22,65	27,96	29,72	35,29	36,61	25 x 9	29,08
M 4x0,70	3,30 R	63 x 13 x 4,5 x 3,4	15,55	18,82	20,83	23,63	27,87	30,13	35,29	36,61	25 x 9	29,08
M 5x0,80	4,20 R	70 x 16 x 6,0 x 4,9	15,55	18,04	20,83	23,50	27,24	30,13	37,27	37,97	25 x 9	29,08
M 6x1,00	5,00 R	80 x 17 x 6,0 x 4,9	17,11	19,81	23,98	25,97	30,60	31,90	37,27	37,97	25 x 9	29,08
M 8x1,00	7,00 D	90 x 20 x 6,0 x 4,9	24,42	28,97	34,38	38,26	46,42	51,66			25 x 9	40,55
M 8x1,25	6,80 R	90 x 20 x 8,0 x 6,2	19,16	22,60	28,04	30,49	38,91	38,16	47,31	49,98	25 x 9	31,54
M 10x1,00	9,00 D	90 x 16 x 7,0 x 5,5	27,22	34,13	40,16	46,11	54,20	64,04			38 x 10	49,56
M 10x1,50	8,50 R	100 x 22 x 10,0 x 8,0	23,56	26,79	33,02	36,15	48,25	47,49	56,38	59,63	38 x 10	43,37
<b>MANGO DELGADO</b>												
M 12x1,50	10,50 D	100 x 22 x 9,0 x 7,0	32,29	39,04	42,72	48,10	60,66	69,58			38 x 10	51,52
M 12x1,75	10,20 D	110 x 24 x 9,0 x 7,0	30,37	36,07	39,98	45,08	52,86	63,44	70,94	76,29	38 x 14	45,49
M 14x1,50	12,50 D	100 x 22 x 11,0 x 9,0	38,26	47,98	50,24	55,49	71,35	81,82			38 x 10	53,86
M 14x2,00	12,00 D	110 x 26 x 11,0 x 9,0	37,97	44,02	49,34	54,24	72,10	79,25	72,43	96,67	38 x 14	46,37
M 16x1,50	14,50 D	100 x 22 x 12,0 x 9,0	47,86	59,01	60,38	69,04	66,68	82,24			45 x 14	73,98
M 16x2,00	14,00 D	110 x 27 x 12,0 x 9,0	44,65	53,20	56,33	62,27	82,32	90,98	98,86	104,26	45 x 18	62,29
M 18x2,50	15,50 D	125 x 30 x 14,0 x 11,0	63,30	71,51	76,92	83,92	107,19	116,94	146,74	157,39	45 x 18	62,29
M 20x2,50	17,50 D	140 x 32 x 16,0 x 12,0	68,39	76,23	87,67	94,45	122,18	131,66	156,39	163,88	45 x 18	62,29
M 22x2,50	19,50 D	140 x 32 x 18,0 x 14,5	82,74	94,06	99,08	106,05	143,30	156,38			55 x 22	92,59
M 24x3,00	21,00 D	160 x 34 x 18,0 x 14,5	98,37	112,61	111,64	121,31	161,47	178,86			55 x 22	92,59



**MACHOS DE MÁQUINA PARA TRABAJOS ESPECIALES HSS-PM**

**INOX**

**M**

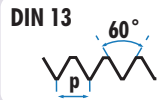

**TOL  
6H**

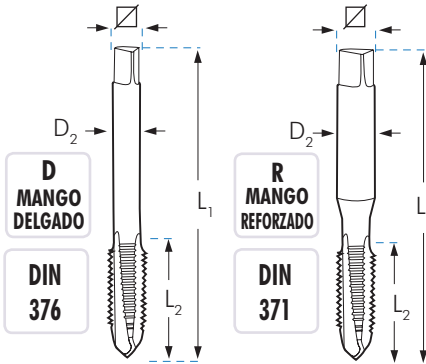

**Vc  
6 m/min**

**Vc  
10 m/min**

**Vc  
12 m/min**



		M2RX	M4RX	M2RXT	M4RXT	M2RXHL	M4RXHL	
CALIDAD		★★	★★	★★★	★★★	★★★★	★★★★	
MATERIAL		HSS PM	HSS PM	HSSCo 5%	HSSCo 5%	HSS PM	HSS PM	
ACABADO		OX	OX	TiN	TiN	HARD LUBE	HARD LUBE	
ÁNGULO DE HÉLICE		FORMA B	FORMA B 35°	FORMA B	FORMA B 35°	FORMA B	FORMA B 35°	
		L1 x L2 x D2 x $\nabla$ mm	€	€	€	€	€	
M 3x0,50	2,50	R 56 x 11 x 3,5 x 2,7	17,41	21,43	20,10	22,75	26,59	31,27
M 4x0,70	3,30	R 63 x 13 x 4,5 x 3,4	18,28	21,43	21,09	23,12	27,93	32,09
M 5x0,80	4,20	R 70 x 16 x 6,0 x 4,9	18,28	20,49	21,09	23,47	27,93	32,57
M 6x1,00	5,00	R 80 x 17 x 6,0 x 4,9	20,03	22,54	22,33	24,54	30,58	34,08
M 8x1,25	6,80	R 90 x 20 x 8,0 x 6,2	22,34	25,68	25,81	28,27	34,15	39,24
M 10x1,50	8,50	R 100 x 22 x 10,0 x 8,0	27,32	30,47	30,17	33,34	41,72	46,54
<b>MANGO DELGADO</b>		M2DX	M4DX	M2DXT	M4DXT	M2DXHL	M4DXHL	
M 12x1,75	10,20	D 110 x 24 x 9,0 x 7,0	35,10	41,10	38,60	43,45	52,65	61,63
M 14x2,00	12,00	D 110 x 26 x 11,0 x 9,0	49,97	54,86	50,29	54,36	69,96	77,47
M 16x2,00	14,00	D 110 x 27 x 12,0 x 9,0	55,65	63,31	54,70	59,94	77,89	93,70
M 18x2,50	15,50	D 125 x 30 x 14,0 x 11,0	83,34	90,08	86,04	87,02	124,99	133,31
M 20x2,50	17,50	D 140 x 32 x 16,0 x 12,0	90,06	95,13	98,24	100,87	132,88	140,76
M 22x2,50	19,50	D 140 x 32 x 18,0 x 14,5	108,07	109,42	112,20	121,48		
M 24x3,00	21,00	D 160 x 34 x 18,0 x 14,5	113,62	124,98	124,33	135,06		
M 27x3,00	24,00	D 160 x 36 x 20,0 x 16,0	148,83	163,71				
M 30x3,50	26,50	D 180 x 40 x 22,0 x 18,0	190,32	209,35				



- Lubricación: **CUT MAGIC XTHICK**
- Se recomienda la aplicación del Aceite de corte CUT MAGIC XTHICK para optimizar el proceso de roscado en Inoxidables, Inconel, Titanio, Dúplex, etc...

Ref. ACXT00250

**MACHOS *Super Plus* PARA EL ROSCADO DE ALEACIONES REFRACTARIAS**

M

DIN 13

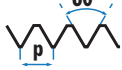
TOL  
6HINOX  
DUPLEX

Ni

INC

Ti

 ESPECIALMENTE RECOMENDADOS  
 EN APLICACIONES AERONAÚTICAS
Vc  
15 m/minINOX  
DUPLEXVc  
6 m/minNICKEL  
INCONELVc  
6 m/min

TITANIO

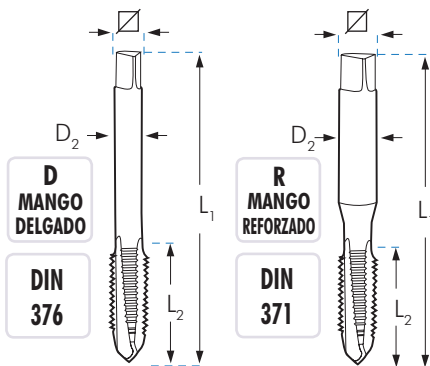

				M2RDU	M4RDU	M2RNI	M3RNI	M2RTIT	M3RTIT
CALIDAD				★★★★	★★★★	★★★★	★★★★	★★★★	★★★★
MATERIAL				HSS V3	HSS V3	HSS PM	HSS PM	HSS PM	HSS PM
ACABADO				TiCN	TiCN	BRILLANTE	BRILLANTE	OX	OX
ÁNGULO DE HÉLICE				FORMA B	41°	FORMA B	15°	FORMA B	15°
		L1 x L2 x D2 x ∅ mm		€	€	€	€	€	€
M 3x0,50	2,50	R 56 x 11 x 3,5 x 2,7		36,74	38,32	68,26	69,75	50,68	55,94
M 4x0,70	3,30	R 63 x 13 x 4,5 x 3,4		36,74	37,53	69,75	71,64	52,26	55,94
M 5x0,80	4,20	R 70 x 16 x 6,0 x 4,9		37,97	38,71	72,21	73,92	53,58	59,58
M 6x1,00	5,00	R 80 x 17 x 6,0 x 4,9		39,02	39,85	72,78	74,84	53,58	60,41
M 8x1,25	6,80	R 90 x 20 x 8,0 x 6,2		54,50	56,82	82,25	84,44	61,91	69,75
M 10x1,50	8,50	R 100 x 22 x 10,0 x 8,0		70,63	72,47	97,72	100,71	76,68	84,05
<b>MANGO DELGADO</b>				M2DDU	M4DDU	M2DNI	M3DNI	M2DTIT	M3DTIT
M 12x1,75	10,20	D 110 x 24 x 9,0 x 7,0		95,49	103,12	125,70	138,98	96,23	104,43
M 14x2,00	12,00	D 110 x 26 x 11,0 x 9,0							
M 16x2,00	14,00	D 110 x 27 x 12,0 x 9,0		140,43	150,16				
M 18x2,50	15,50	D 125 x 30 x 14,0 x 11,0							
M 20x2,50	17,50	D 140 x 32 x 16,0 x 12,0		207,94	224,60				
M 22x2,50	19,50	D 140 x 32 x 18,0 x 14,5							
M 24x3,00	21,00	D 160 x 34 x 18,0 x 14,5		281,64	286,47				
M 27x3,00	24,00	D 160 x 36 x 20,0 x 16,0		361,83	379,28				
M 30x3,50	26,50	D 180 x 40 x 22,0 x 18,0		427,33	447,15				

**MACHOS DE MÁQUINA PARA ACEROS ESTRUCTURALES SUPER BLANDOS < DE 450 N/mm<sup>2</sup>**

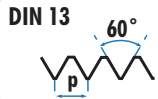

**HSSCo**  
5%

**OX**

**TOL**  
6H

**APLICACIONES**

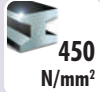



**ST52**

**AI**

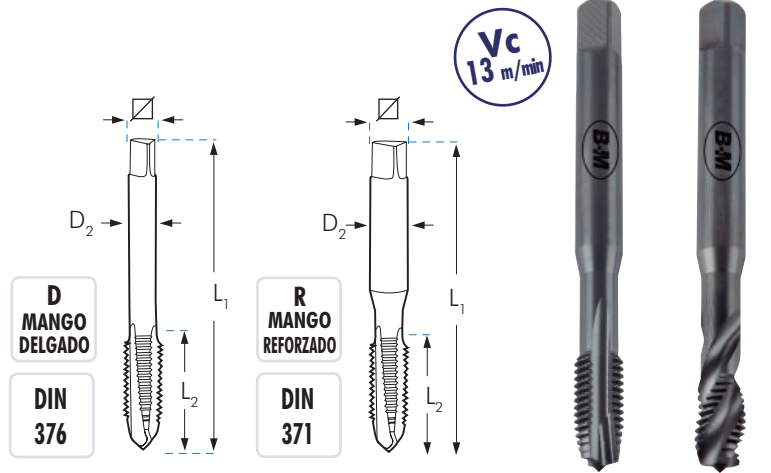
Geometría de corte específica para materiales blandos, no genera SOBREMEDIDA y se ajusta perfectamente a este tipo de materiales donde los machos convencionales, pueden provocar agrandamientos a la hora de generar la rosca.

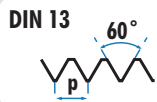
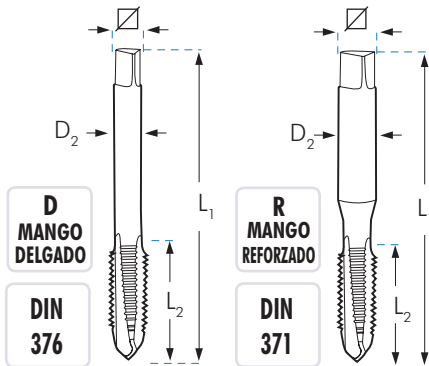

		L <sub>1</sub> x L <sub>2</sub> x D <sub>2</sub> x $\nabla$ mm	M2RSS	M4RSS
			FORMA B	35°
			€	€
M 3 x 0,50	2,50	R 56 x 11 x 3,5 x 2,7	13,58	17,80
M 4 x 0,70	3,30	R 63 x 13 x 4,5 x 3,4	14,21	17,81
M 5 x 0,80	4,20	R 70 x 16 x 6,0 x 4,9	14,23	17,08
M 6 x 1,00	5,00	R 80 x 17 x 6,0 x 4,9	15,61	18,73
M 8 x 1,25	6,80	R 90 x 20 x 8,0 x 6,2	17,51	21,19
M 10 x 1,50	8,50	R 100 x 22 x 10,0 x 8,0	21,57	25,09
<b>MANGO DELGADO</b>			M2DSS	M4DSS
M 12 x 1,75	10,20	D 110 x 24 x 9,0 x 7,0	27,20	32,32
M 14 x 2,00	12,00	D 110 x 26 x 11,0 x 9,0	40,16	46,54
M 16 x 2,00	14,00	D 110 x 27 x 12,0 x 9,0	46,97	56,22
M 18 x 2,50	15,50	D 125 x 30 x 14,0 x 11,0	66,91	72,89
M 20 x 2,50	17,50	D 140 x 32 x 16,0 x 12,0	72,23	80,80
M 22 x 2,50	19,50	D 140 x 32 x 18,0 x 14,5	86,70	94,82
M 24 x 3,00	21,00	D 160 x 34 x 18,0 x 14,5	103,28	115,25
M 27 x 3,00	24,00	D 160 x 36 x 20,0 x 16,0	129,17	141,80
M 30 x 3,50	26,50	D 180 x 40 x 22,0 x 18,0	165,97	181,73

**MACHOS DE MÁQUINA PARA TRABAJOS ESPECIALES HSS-V3**

**HSS  
V3**
**TOL  
6H**
**MATERIALES  
DUROS**

**Vc  
7 m/min**
**Vc  
9 m/min**

		M2RMD	M4RMD	M2RMDTX	M4RMDTX
CALIDAD		★★★	★★★	★★★★	★★★★
MATERIAL		HSS V3	HSS V3	HSS V3	HSS V3
ACABADO		OX	OX	TINALOX	TINALOX
ÁNGULO DE HÉLICE		FORMA B	35°	FORMA B	35°
	$L_1 \times L_2 \times D_2 \times \square$ mm	€	€	€	€
M 3x0,50	2,50 R 56 x 11 x 3,5 x 2,7	15,83	17,33	23,22	27,30
M 4x0,70	3,30 R 63 x 13 x 4,5 x 3,4	15,88	17,39	24,40	28,59
M 5x0,80	4,20 R 70 x 16 x 6,0 x 4,9	15,88	18,24	24,40	28,59
M 6x1,00	5,00 R 80 x 17 x 6,0 x 4,9	18,03	18,85	26,72	30,06
M 8x1,25	6,80 R 90 x 20 x 8,0 x 6,2	19,26	22,24	29,82	34,28
M 10x1,50	8,50 R 100 x 22 x 10,0 x 8,0	22,19	25,61	37,74	42,09
<b>MANGO DELGADO</b>		M2DMD	M4DMD	M2DMDTX	M4DMDTX
M 12x1,75	10,20 D 110 x 24 x 9,0 x 7,0	30,53	35,22	48,51	56,79
M 14x2,00	12,00 D 110 x 26 x 11,0 x 9,0	40,05	41,81	69,03	75,79
M 16x2,00	14,00 D 110 x 27 x 12,0 x 9,0	44,80	50,58	76,89	91,66
M 18x2,50	15,50 D 125 x 30 x 14,0 x 11,0	66,80	71,96	113,04	128,02
M 20x2,50	17,50 D 140 x 32 x 16,0 x 12,0	72,19	75,97	122,17	135,14

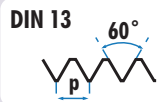

MACHOS DE MÁQUINA PARA MATERIALES TEMPLADOS (HARDOX 450/500)



TiCN

TOL  
6H

HSS  
PM

MD

MATERIALES  
MUY  
DUROS

48  
HRC

48-62  
HRC

Vc  
5 m/min

MD

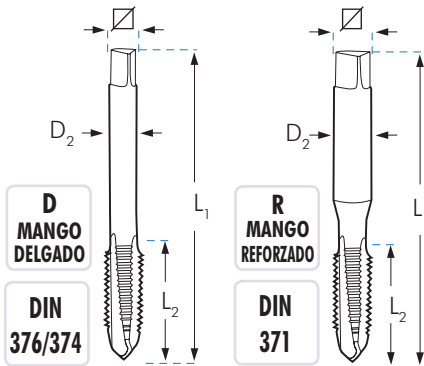

Icon	Icon	L1 x L2 x D2 x $\square$ mm	M2RC	M3RC	M2HRC	M4HRC	M1RHMC
			FORMA B	15°	FORMA B	35°	FORMA C
			€	€	€	€	€
M 2 x 0,40	1,60	R 40 x 9 x 2,5 x 2,1			36,24	39,63	1,70
M 3 x 0,50	2,50	R 56 x 11 x 3,5 x 2,7	33,07	35,18	33,07	37,04	2,60
M 4 x 0,70	3,30	R 63 x 13 x 4,5 x 3,4	34,35	37,47	34,35	38,47	3,40
M 5 x 0,80	4,20	R 70 x 16 x 6,0 x 4,9	34,68	36,61	34,68	38,84	4,30
M 6 x 1,00	5,00	R 80 x 17 x 6,0 x 4,9	36,16	42,54	36,16	40,50	5,10
M 8 x 1,25	6,80	R 90 x 20 x 8,0 x 6,2	41,77	47,66	44,96	50,36	6,90
M 10 x 1,50	8,50	R 100 x 22 x 10,0 x 8,0	50,00	59,05	53,81	56,50	8,60
<b>MANGO DELGADO</b>			M2DC	M3DC	M2HDC	M4HDC	M1DHMC
M 12 x 1,75	10,20	D 110 x 24 x 9,0 x 7,0	74,78	116,07	82,14	89,54	10,40
M 14 x 2,00	12,00	D 110 x 26 x 11,0 x 9,0	100,97	118,09	97,40	106,17	12,10
M 16 x 2,00	14,00	D 110 x 27 x 12,0 x 9,0	113,92	135,65	108,30	118,05	16,10
M 18 x 2,50	15,50	D 125 x 30 x 14,0 x 11,0	144,26	205,41	114,56	124,87	15,75
M 20 x 2,50	17,50	D 140 x 32 x 16,0 x 12,0	228,46	237,79	158,32	172,57	17,75
M 22 x 2,50	19,50	D 140 x 32 x 18,0 x 14,5			195,50	214,03	
M 24 x 3,00	21,00	D 160 x 34 x 18,0 x 14,5			214,03	233,30	
M 27 x 3,00	24,00	D 160 x 36 x 20,0 x 16,0			267,32	301,23	
M 30 x 3,50	26,50	D 180 x 40 x 22,0 x 18,0			328,36	354,64	

HRC	Vc (m/min)
48 Hrc	8 m/min
56 Hrc	6 m/min
62Hrc	3 m/min

- Lubricación: **CUT MAGIC XTHICK**
- Se recomienda roscar la pieza sobre el mismo utillaje utilizado para el taladro previo y en la misma posición, para garantizar coaxialidad entre macho y orificio previo.

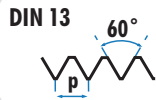
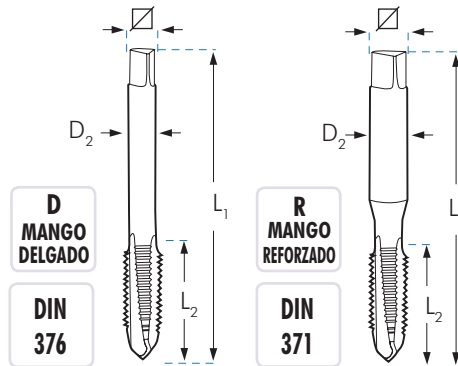

Ref. ACXT00250

**MACHOS DE MÁQUINA TODO TERRENO**
**TODO  
TERRENO**

**HSSCo  
5%**
**TiN**
**TOL  
6H**
**APLICACIONES**
**1200  
N/mm<sup>2</sup>**
**Al**
**FUNDICIÓN**
**Ti**
**INOX**
**Vc  
13  
m/min**

				M2RD	M4RD
		L <sub>1</sub> x L <sub>2</sub> x D <sub>2</sub> x		FORMA B	
		mm		€	€
M 3 x 0,50	2,50	R	56 x 11 x 3,5 x 2,7	24,90	31,12
M 4 x 0,70	3,30	R	63 x 13 x 4,5 x 3,4	26,64	31,12
M 5 x 0,80	4,20	R	70 x 16 x 6,0 x 4,9	28,34	32,24
M 6 x 1,00	5,00	R	80 x 17 x 6,0 x 4,9	29,33	33,46
M 8 x 1,25	6,80	R	90 x 20 x 8,0 x 6,2	34,36	38,18
M 10 x 1,50	8,50	R	100 x 22 x 10,0 x 8,0	39,64	45,23
<b>MANGO DELGADO</b>				M2DD	M4DD
M 12 x 1,75	10,20	D	110 x 24 x 9,0 x 7,0	49,95	59,47
M 14 x 2,00	12,00	D	110 x 26 x 11,0 x 9,0	65,24	71,69
M 16 x 2,00	14,00	D	110 x 27 x 12,0 x 9,0	73,10	79,12
M 18 x 2,50	15,50	D	125 x 30 x 14,0 x 11,0	114,24	117,14
M 20 x 2,50	17,50	D	140 x 32 x 16,0 x 12,0	116,36	120,72

**MACHOS DE MÁQUINA PARA TRABAJOS ESPECIALES HSSCo**

**Al**

**FUNDICIÓN**

**LATÓN**

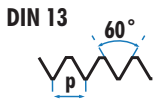

**HSSCo**  
5%

**MD**

**TOL**  
6H

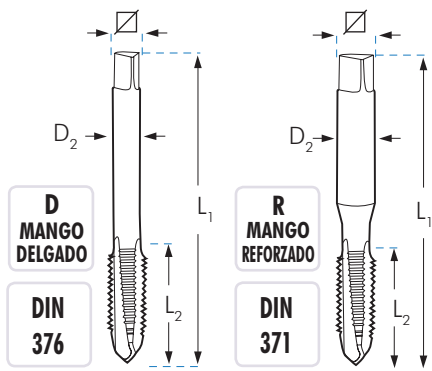

**Vc**  
18 m/min



**Vc**  
11 m/min



**Vc**  
21 m/min



**Vc**  
16 m/min



**Vc**  
19 m/min



		M5R	M6R	M1RFM	MHMTR	M1RL	M1RLCRN
APLICACIÓN		<b>Al</b>	<b>Al</b>	<b>FUNDICIÓN</b>	<b>FUNDICIÓN</b>	<b>LATÓN</b>	<b>LATÓN</b>
MATERIAL		HSSCo 5%	HSSCo 5%	HSSCo 5%	MD	HSSCo 5%	HSSCo 5%
ACABADO		BRILLANTE	BRILLANTE	<b>OX</b>	BRILLANTE	BRILLANTE	CrN
FORMA		DIENTE ALTERNO	2 CANALES	FORMA C	FORMA C	FORMA C	FORMA C
	$L_1 \times L_2 \times D_2 \times \nabla$ mm	€	€	€	€	€	€
M 3x0,50	2,50 R 56 x 11 x 3,5 x 2,7	21,48	23,05	15,20	77,04	18,20	20,67
M 4x0,70	3,30 R 63 x 13 x 4,5 x 3,4	21,60	23,05	15,71	77,04	19,32	22,78
M 5x0,80	4,20 R 70 x 16 x 6,0 x 4,9	21,48	23,54	15,71	77,04	19,32	22,87
M 6x1,00	5,00 R 80 x 17 x 6,0 x 4,9	22,64	25,45	17,84	87,87	21,17	24,97
M 8x1,25	6,80 R 90 x 20 x 8,0 x 6,2	27,10	30,50	19,98	98,11	24,14	30,36
M 10x1,50	8,50 R 100 x 22 x 10,0 x 8,0	32,68	36,07	22,86	122,96	29,04	36,94
<b>MANGO DELGADO</b>		M5D	M6D	M1DFM	MHM1D	M1DL	M1DLCRN
M 12x1,75	10,20 D 110 x 24 x 9,0 x 7,0	40,77	44,49	28,75	168,36	33,88	44,65
M 14x2,00	12,00 D 110 x 26 x 11,0 x 9,0	73,82	76,83	47,26	262,28	41,59	54,41
M 16x2,00	14,00 D 110 x 27 x 12,0 x 9,0	80,46	87,13	55,60	312,03	47,85	60,83
M 18x2,50	15,50 D 125 x 30 x 14,0 x 11,0			77,78	382,49	62,76	77,05
M 20x2,50	17,50 D 140 x 32 x 16,0 x 12,0			78,08	463,18	70,44	85,78



- Lubricación: **CUT MAGIC ALUMINIO**
- Se recomienda la aplicación del Aceite de corte CUT MAGIC ALUMINIO para optimizar el proceso de roscado en Aluminio y sus fundiciones.

Ref. ACAL00250

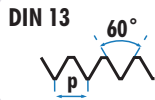
**MACHOS DE MÁQUINA PARA ROSCADO POR LAMINACIÓN**

**HSSCo**  
**5%**
**HSSCo**  
**8%**
**TOL**  
**6HX**
**APLICACIONES**

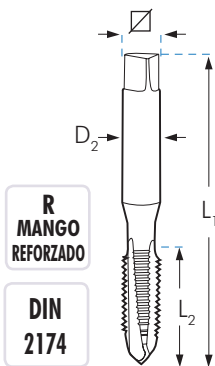
**Al**
**FUNDICIÓN**

*Plus*
**INOX**

				M07R	M07RT	M07RCR	M07RCCR	M09RCCR	M07RXTCR
APLICACIÓN				LAMINACION	LAMINACION	LAMINACION	LAMINACION	LAMINACION	LAMINACION
MATERIAL				HSSCo 5%	HSSCo 5%	HSSCo 5%	HSSCo 5%	HSSCo 8%	HSSCo 5%
ACABADO				OX	TiN	OX	TiCN	TiCN	TiN
FORMA									
			$L_1 \times L_2 \times D_2 \times \nabla$ mm	€	€	€	€	€	€
M 3x0,50	2,75	R	56 x 11 x 3,5 x 2,7	30,39	32,99	32,52	37,07	100,01	74,58
M 3,5x0,60	3,20	R	56 x 11 x 3,5 x 2,7	31,94	36,38	33,60	39,23		
M 4x0,70	3,65	R	63 x 13 x 4,5 x 3,4	30,39	34,41	32,52	38,66	101,27	74,58
M 5x0,80	4,60	R	70 x 16 x 6,0 x 4,9	30,39	34,41	32,52	38,66	102,62	80,49
M 6x1,00	5,50	R	80 x 17 x 6,0 x 4,9	32,81	36,36	35,09	40,86	104,24	80,49
M 8x1,25	7,40	R	90 x 20 x 8,0 x 6,2	38,24	47,99	40,91	53,94	115,64	96,33
M 10x1,50	9,30	R	100 x 22 x 10,0 x 8,0	42,53	53,81	45,50	59,37	138,07	117,60
<b>MANGO DELGADO</b>				M07D	M07DT	M07DCR	M07DCCR	M09DCCR	M07DXTCR
M 12x1,75	11,20	D	110 x 24 x 9,0 x 7,0	50,12	70,37	51,63	67,98	163,44	153,14
M 14x2,00	13,05	D	110 x 26 x 11,0 x 9,0	90,36	111,13	91,28	110,37	203,40	220,30
M 16x2,00	15,05	D	110 x 27 x 12,0 x 9,0	106,08	125,17	107,15	112,16	279,75	224,12
M 18x2,50	16,80	D	125 x 30 x 14,0 x 11,0	121,73	149,67	122,95	138,05	331,47	
M 20x2,50	18,80	D	140 x 32 x 16,0 x 12,0	160,39	226,57	162,02	193,72	366,97	

MACHOS DE MÁQUINA HSSCo TOLERANCIAS ESPECIALES Y SOBREMEDIDAS



		M2R4H	M4R4H	M2R6G	M4R6G	M2R7G	M4R7G	M2R+0,1	M4R+0,1	M2R+0,2	M4R+0,2
TOLERANCIA		TOL 4H	TOL 4H	TOL 6G	TOL 6G	TOL 7G	TOL 7G	TOL 6H (+0,1)	TOL 6H (+0,1)	TOL 6H (+0,2)	TOL 6H (+0,2)
MATERIAL		HSSCo 5%	HSSCo 5%	HSSCo 5%	HSSCo 5%	HSSCo 5%	HSSCo 5%	HSSCo 5%	HSSCo 5%	HSSCo 5%	HSSCo 5%
ACABADO		BRILLANTE	BRILLANTE	BRILLANTE	BRILLANTE	BRILLANTE	BRILLANTE	BRILLANTE	BRILLANTE	BRILLANTE	BRILLANTE
FORMA		FORMA B	FORMA B 35°	FORMA B	FORMA B 35°	FORMA B	FORMA B 35°	FORMA B	FORMA B 35°	FORMA B	FORMA B 35°
		€	€	€	€	€	€	€	€	€	€
M 3x0,50	2,50 R 56x11x 3,5x 2,7	20,79	25,71	15,25	18,15	20,79	25,71	21,46	28,63	24,62	30,49
M 4x0,70	3,30 R 63x13x 4,5x 3,4	21,27	25,71	15,25	18,15	21,27	25,71	21,97	28,63	25,19	30,49
M 5x0,80	4,20 R 70x16x 6,0x 4,9	21,27	24,63	15,25	17,81	21,27	24,63	21,97	27,42	25,19	29,19
M 6x1,00	5,00 R 80x17x 6,0x 4,9	23,38	27,03	16,42	19,56	23,38	27,03	24,12	30,09	27,69	32,04
M 8x1,00	7,00 D 90x20x 6,0x 4,9			31,98	35,37						
M 8x1,25	6,75 R 90x20x 8,0x 6,2	26,18	30,86	19,09	22,92	26,18	30,86	27,03	34,34	31,02	36,58
M 10x1,00	9,00 D 90x16x 7,0x 5,5			37,77	43,96						
M 10x1,50	8,50 R 100x22x10,0x 8,0	32,19	36,63	23,49	26,22	32,19	36,63	33,25	40,73	38,17	43,36
	<b>MANGO DELGADO</b>	M2D4H	M4D4H	M2D6G	M4D6G	M2D7G	M4D7G	M2D+0,1	M4D+0,1	M2D+0,2	M4D+0,2
M 12x1,50	10,50 D 100x22x 9,0x 7,0			68,82	81,59						
M 12x1,75	10,20 D 110x24x 9,0x 7,0	41,51	49,28	30,98	37,32	41,51	49,28	41,64	52,79	47,31	56,22
M 14x2,00	12,00 D 110x26x11,0x 9,0			38,06	45,73			67,93	84,04	77,20	89,50
M 16x2,00	14,00 D 110x27x12,0x 9,0			47,04	55,23			79,90	101,56	90,82	108,15
M 18x2,50	15,50 D 125x30x14,0x11,0			66,33	68,38			120,81	136,78	128,64	145,65
M 20x2,50	17,50 D 140x32x16,0x12,0			68,51	78,59			130,54	145,55	139,00	154,99

4H.- Para roscas muy precisas. Ajuste más exacto.

6G.- Para roscas con recubrimientos. Espesores entre 20 - 40 μ

7G.- Para roscas con recubrimientos. Espesores entre 40 - 50 μ





6H. (+0,1)- Hay que añadir 0,10mm a la broca previa.

6H. (+0,2)- Hay que añadir 0,20mm a la broca previa.

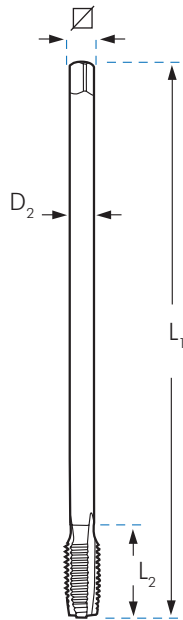





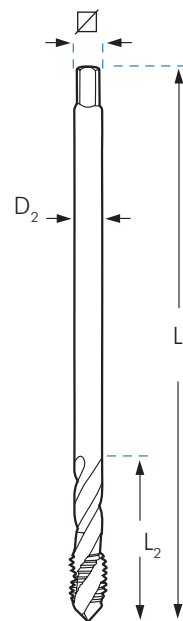

## MACHOS DE MÁQUINA EXTRALARGOS HSSCo

**FORMA B****HSSCo 5%****BRILLANTE****TOL 6H****R MANGO REFORZADO****DIN 371****D MANGO DELGADO****DIN 376**

				M2L
			L <sub>1</sub> x L <sub>2</sub> x D <sub>2</sub> x  mm	FORMA B €
M	3x0,50	2,50	R 100 x 10 x 3,5 x 2,7	35,72
M	4x0,70	3,30	R 120 x 12 x 4,5 x 3,4	36,50
M	5x0,80	4,20	R 140 x 14 x 6,0 x 4,9	36,50
M	6x1,00	5,00	R 160 x 16 x 6,0 x 4,9	40,11
M	7x1,00	6,00	R 160 x 17 x 7,0 x 5,5	44,69
M	8x1,25	6,80	R 180 x 18 x 8,0 x 6,2	47,03

				M2L-D
<b>MANGO DELGADO</b>				
M	6x1,00	5,00	D 160 x 16 x 4,5 x 3,4	40,85
M	8x1,25	6,80	D 180 x 18 x 6,2 x 5,0	47,92
M	10x1,50	8,50	D 200 x 20 x 7,0 x 5,5	57,89
M	12x1,75	10,20	D 220 x 22 x 8,5 x 6,5	71,23
M	14x2,00	12,00	D 220 x 25 x 10,5 x 8,0	108,44
M	16x2,00	14,00	D 220 x 28 x 12,5 x 10,0	127,56
M	18x2,50	15,50	D 250 x 32 x 14,0 x 11,0	232,10
M	20x2,50	17,50	D 250 x 32 x 16,0 x 12,0	250,86

**HSSCo 5%****BRILLANTE****TOL 6H****R MANGO REFORZADO****DIN 371****D MANGO DELGADO****DIN 376**

				M4L
			L <sub>1</sub> x L <sub>2</sub> x D <sub>2</sub> x  mm	 €
M	3x0,50	2,50	R 100 x 10 x 3,5 x 2,7	44,19
M	4x0,70	3,30	R 120 x 12 x 4,5 x 3,4	44,19
M	5x0,80	4,20	R 140 x 14 x 6,0 x 4,9	42,34
M	6x1,00	5,00	R 160 x 16 x 6,0 x 4,9	46,45
M	7x1,00	6,00	R 160 x 17 x 7,0 x 5,5	51,72
M	8x1,25	6,80	R 180 x 18 x 8,0 x 6,2	56,44

				M4L-D
<b>MANGO DELGADO</b>				
M	6x1,00	5,00	D 160 x 16 x 4,5 x 3,4	47,33
M	8x1,25	6,80	D 180 x 18 x 6,2 x 5,0	56,37
M	10x1,50	8,50	D 200 x 20 x 7,0 x 5,5	65,41
M	12x1,75	10,20	D 220 x 22 x 8,5 x 6,5	84,61
M	14x2,00	12,00	D 220 x 25 x 10,5 x 8,0	121,50
M	16x2,00	14,00	D 220 x 28 x 12,5 x 10,0	176,09
M	18x2,50	15,50	D 250 x 32 x 14,0 x 11,0	262,81
M	20x2,50	17,50	D 250 x 32 x 16,0 x 12,0	279,70

**MACHO TUERQUERO DE ROSCA MÉTRICA DIN 357**



**HSSCo**  
5%

**BRILLANTE**

**TOL**  
6H

**DIN**  
357

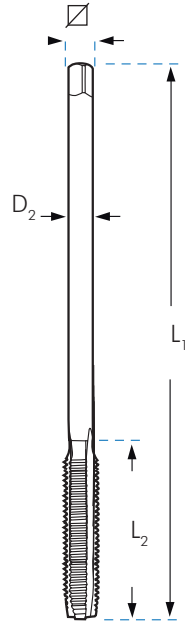

				MTU	
			$L_1 \times L_2 \times D_2 \times \square$ mm	FORMA A	€
M	3x0,50*	2,50	D 70 x 22 x 2,2		22,76
M	4x0,70	3,30	D 90 x 25 x 2,8 x 2,1		22,76
M	5x0,80	4,20	D 100 x 28 x 3,5 x 2,7		22,76
M	6x1,00	5,00	D 110 x 32 x 4,5 x 3,4		22,76
M	8x1,25	6,80	D 125 x 40 x 6,0 x 4,9		27,44
M	10x1,50	8,50	D 140 x 45 x 7,0 x 5,5		26,82
M	12x1,75	10,20	D 180 x 50 x 9,0 x 7,0		32,48
M	14x2,00	12,00	D 200 x 56 x 11,0 x 9,0		51,33
M	16x2,00	14,00	D 200 x 63 x 12,0 x 9,0		63,55
M	18x2,50	15,50	D 220 x 63 x 14,0 x 11,0		85,49
M	20x2,50	17,50	D 250 x 70 x 16,0 x 12,0		120,69
M	22x2,50	19,50	D 280 x 80 x 18,0 x 14,5		148,08
M	24x3,00	21,00	D 280 x 80 x 18,0 x 14,5		201,48

\* Mango cilíndrico

Machos y Terrajas

Rosa

**BLUE-MASTER**  
by CELESA

CONSULTE NUESTRA AMPLIA GAMA DE HERRAMIENTAS  
PARA LA REPARACIÓN DE ROSCAS



**INSERTOS LIBRES**

**INSERTOS SÓLIDOS CON SELLADOR ANAERÓBICO**

**INSERTOS AUTORROSCANTES**

**CASQUILLOS ROSCADOS DE SEGURIDAD**

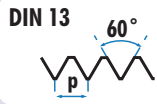
**BROCA MACHO HSSCo**

**HSSCo**  
 5%

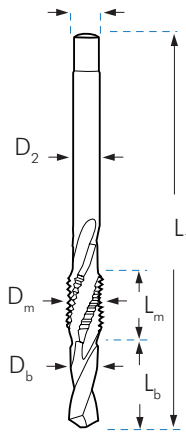
BRILLANTE

**TOL**  
**6H**
**R**  
**MANGO**  
**REFORZADO**
**DIN**  
**371**
**D**  
**MANGO**  
**DELGADO**
**DIN**  
**376**

		L <sub>b</sub> mm	L <sub>m</sub> mm	L <sub>1</sub> mm	D <sub>b</sub> mm	D <sub>m</sub> mm	D <sub>2</sub> mm	∅ mm	M8M €
M 3x0,50	R	9,0	12,5	62,0	2,50	3,0	3,5	2,7	34,90
M 4x0,70	R	10,0	16,0	66,0	3,30	4,0	4,5	3,4	34,90
M 5x0,80	R	12,5	18,0	75,5	4,20	5,0	6,0	4,9	36,26
M 6x1,00	R	14,0	20,0	81,0	5,00	6,0	6,0	4,9	40,05
M 8x1,00	R	20,0	14,0	91,0	7,00	8,0	6,0	4,9	47,01
M 8x1,25	R	20,0	14,0	91,0	6,75	8,0	8,0	6,2	47,86

**MANGO DELGADO**

M 8x1,25	D	20,0	14,0	91,0	6,75	8,0	6,0	4,9	48,77
M 10x1,00	D	20,0	15,0	95,0	9,00	10,0	7,0	5,5	58,35
M 10x1,50	D	25,0	18,0	105,0	8,50	10,0	7,0	5,5	61,93
M 12x1,50	D	24,0	18,0	110,0	10,50	12,0	9,0	7,0	67,59
M 12x1,75	D	28,0	20,0	118,0	10,20	12,0	9,0	7,0	67,20
M 14x1,50	D	28,0	20,0	118,0	12,50	14,0	11,0	9,0	106,96
M 16x2,00	D	28,0	22,0	130,0	12,00	14,0	11,0	9,0	121,66
M 18x2,50	D	40,0	26,0	151,0	15,50	18,0	14,0	11,0	233,38
M 20x2,50	D	45,0	30,0	168,0	17,50	20,0	16,0	12,0	335,15

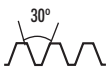
 Nota: Jamás emplee los Broca-Machos en agujeros ciegos o en pasantes más profundos que L<sub>b</sub>
**MACHO DE MÁQUINA ROSCA TRAPEZOIDAL HSS**

**HSS**

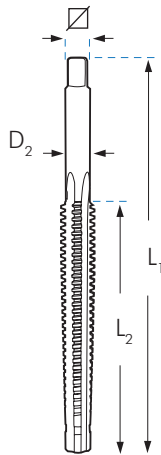
BRILLANTE

**DIN**  
**103**
**TOL**  
**7H**

		∅	L <sub>1</sub> x L <sub>2</sub> x D <sub>2</sub> x ∅ mm	MRTM €
Tr 14 x 3		11,25	160 x 105 x 10,5 x 8,0	538,14
Tr 16 x 4		12,25	205 x 110 x 11,5 x 9,0	560,23
Tr 18 x 4		14,25	215 x 120 x 13,0 x 10,0	590,57
Tr 20 x 4		16,25	230 x 130 x 15,0 x 12,0	593,33
Tr 22 x 5		17,25	270 x 165 x 16,0 x 12,0	781,00
Tr 24 x 5		19,25	280 x 165 x 18,0 x 14,5	885,88
Tr 26 x 5		21,25	290 x 170 x 20,0 x 16,0	916,60
Tr 28 x 5		23,25	300 x 180 x 22,0 x 18,0	1.038,31
Tr 30 x 6		24,25	345 x 200 x 23,0 x 18,0	1.194,95

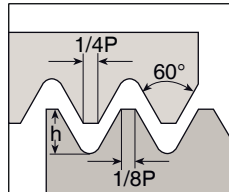
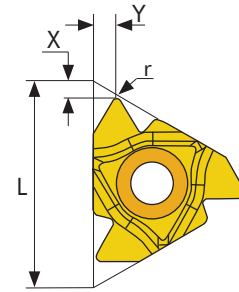
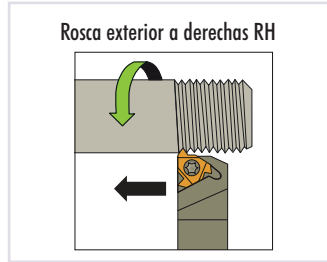
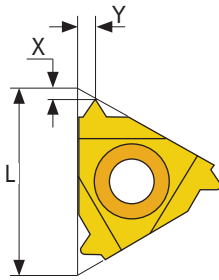
PLAQUITAS PARA ROSCADO DE EXTERIORES



Norma: R262 (DIN 13)  
Tolerancia clase: 6g/6H

Perfil Total

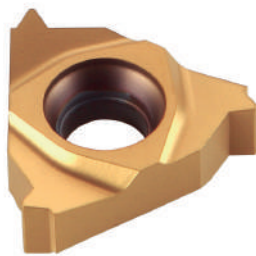
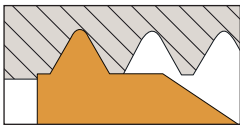

Perfil Parcial

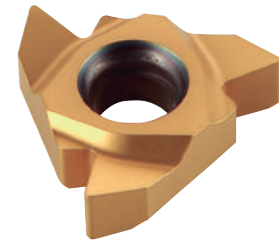
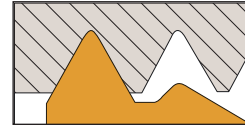

Rosca el perfil completo, terminando el diámetro exterior de la rosca.  
Utilizaremos una plaquita diferente para cada paso.

No termina el diámetro exterior de la rosca.  
La misma plaquita puede ser utilizada para una gama de diferentes pasos, que tengan el mismo ángulo de rosca.

PERFIL TOTAL 60°

ROSCADO EXTERIOR	L	PASO	h	X	Y	€
PRE-16-075	16	0,75	0,46	0,6	0,6	24,11
PRE-16-100		1,00	0,61	0,7	0,7	24,11
PRE-16-125		1,25	0,77	0,8	0,9	24,11
PRE-16-150		1,50	0,92	0,8	1	24,11
PRE-16-175		1,75	1,07	0,9	1,2	24,11
PRE-16-200		2,00	1,23	1	1,3	24,11
PRE-16-250		2,50	1,53	1,1	1,5	24,11
PRE-16-300		3,00	1,84	1,2	1,6	24,11

PERFIL PARCIAL 60°

ROSCADO EXTERIOR	L	RANGOS MÉTRICOS	RANGO PULGADAS	r	X	Y	€
PPRE-16-150	16	0,50-1,50	48 - 16	0,05	0,80	0,90	24,11
PPRE-16-300		1,75-3,00	14 - 8	0,27	1,20	1,70	24,11

PORTAHERRAMIENTAS DE ROSCADO DE EXTERIORES

ROSCADO EXTERIOR	H1=H=B=F	L1	L2	€
PEXT-20-16	20	128	30	154,42
PEXT-25-16	25	153	30	176,29

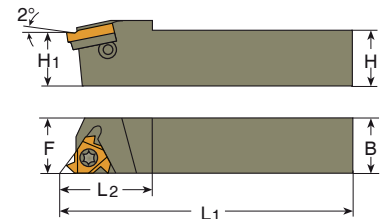

ACERO BLANDO 70 kg/mm <sup>2</sup> BC2	Vc 25 m/min	ALUMINIO BC16	Vc 50 m/min
ACERO TRATADO 120 kg/mm <sup>2</sup> BC5	13 m/min	TITANIO BC42	18 m/min
INOXIDABLE BC50	11 m/min	FUNDICIÓN BC7	25 m/min
		LATÓN BC66	50 m/min

FÓRMULA MATEMÁTICA PARA OBTENER LA VELOCIDAD DE GIRO DE LA PIEZA (RPM)

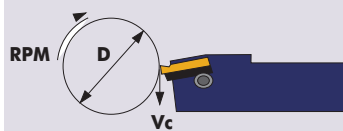

RPM: Revoluciones x minuto  
Vc: Velocidad de Corte (m/min)  
D: Diámetro Pieza (mm)

$$RPM = \frac{1000 \times Vc}{\pi \times D}$$

Las RPM-s se Obtienen en función de Vc y D

## PLAQUITAS PARA ROSCADO DE INTERIORES

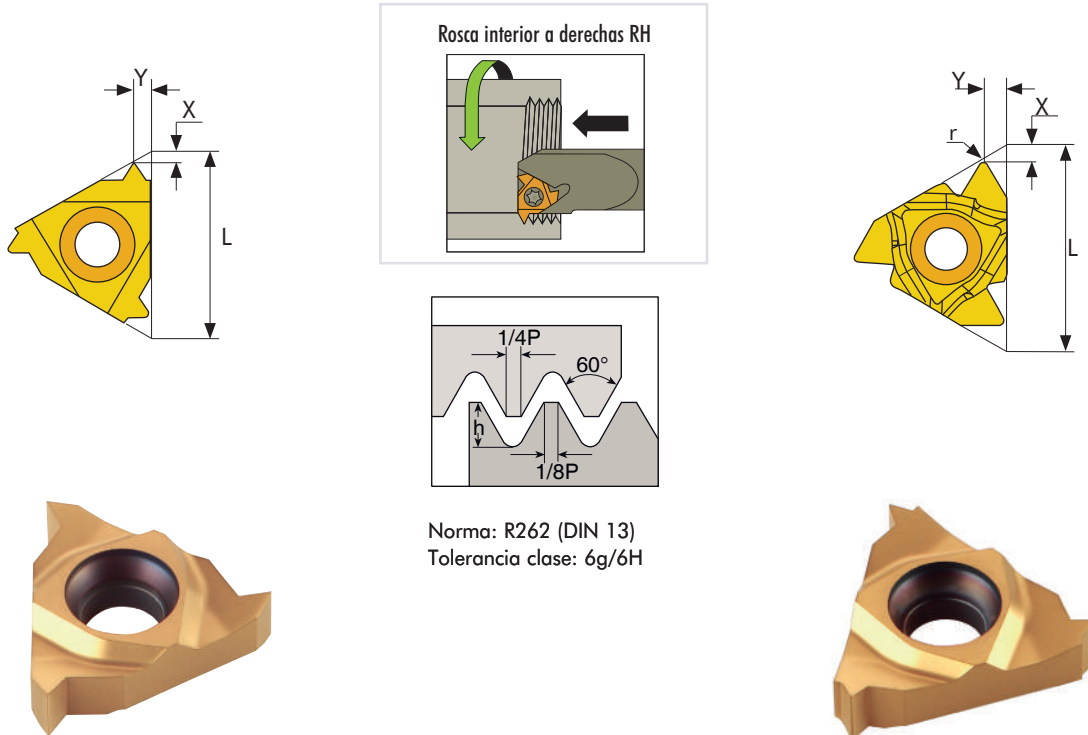

## PERFIL TOTAL 60°

ROSCADO INTERIOR	L	PASO	h	X	Y	€
PRI-16-075	16	0,75	0,43	0,6	0,6	24,11
PRI-16-100		1,00	0,58	0,6	0,7	24,11
PRI-16-125		1,25	0,72	0,8	0,9	24,11
PRI-16-150		1,50	0,87	0,8	1,0	24,11
PRI-16-175		1,75	1,01	0,9	1,2	24,11
PRI-16-200		2,00	1,15	1,0	1,3	24,11
PRI-16-250		2,50	1,44	1,1	1,5	24,11
PRI-16-300		3,00	1,73	1,1	1,5	24,11

## PERFIL PARCIAL 60°

ROSCADO INTERIOR	L	RANGOS MÉTRICOS	RANGO PULGADAS	r	X	Y	€
PPRI-16-150	16	0,50-1,50	48 - 16	0,05	0,80	0,90	24,11
PPRI-16-300		1,75-3,00	14 - 8	0,16	1,20	1,70	24,11

## PORTAHERRAMIENTAS DE ROSCADO DE INTERIORES

ROSCADO INTERIOR	L	L1	D	D1	A	Ø Mín. agujero	€
PINT-20-16	180	40	20	20	18	24	173,75
PINT-25-16	200	45	25	24,6	22,6	29	212,45

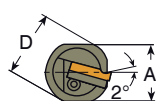
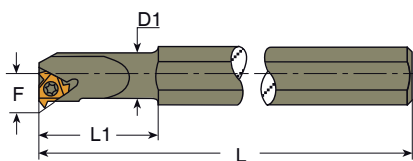



**MACHOS DE MÁQUINA HSSCo EN ESTUCHES METÁLICOS**

**USO  
GENERAL**

**HSSCo  
5%**



Ref. JM6



Ref. JM2





Ref. JM8



Ref. JM4

**CONTENIDO**

	FORMA C	FORMA B	 15°	 35°	 HSS	HSSCo 5% €
JM5	M3 - M4 - M5 - M6 M8 - M10 - M12	-	-	-	-	100,46
JM1	M3 - M4 - M5 - M6 M8 - M10 - M12	-	-	-	2.5 / 3.3 / 4.2 / 5.0 6.8 / 8.5 / 10.2 mm	120,16
JM6	-	M3 - M4 - M5 - M6 M8 - M10 - M12	-	-	-	107,04
JM2	-	M3 - M4 - M5 - M6 M8 - M10 - M12	-	-	2.5 / 3.3 / 4.2 / 5.0 6.8 / 8.5 / 10.2 mm	120,38
JM7	-	-	M3 - M4 - M5 - M6 M8 - M10 - M12	-	-	133,35
JM3	-	-	M3 - M4 - M5 - M6 M8 - M10 - M12	-	2.5 / 3.3 / 4.2 / 5.0 6.8 / 8.5 / 10.2 mm	159,34
JM8	-	-	-	M3 - M4 - M5 - M6 M8 - M10 - M12	-	135,65
JM4	-	-	-	M3 - M4 - M5 - M6 M8 - M10 - M12	2.5 / 3.3 / 4.2 / 5.0 6.8 / 8.5 / 10.2 mm	157,64



## MACHOS DE MÁQUINA EN ESTUCHES METÁLICOS

Plus



Ref. JMPT2

## CONTENIDO

	FORMA B	BRILLANTE	 35°	BRILLANTE	 HSSCo 5%	HSS PM €		TiN €
JMP6	M3 - M4 - M5 - M6 M8 - M10 - M12		-		-	111,54	JMPT6	160,87
JMP2	M3 - M4 - M5 - M6 M8 - M10 - M12		-		2.5 / 3.3 / 4.2 / 5.0 6.8 / 8.5 / 10.2 mm	146,27	JMPT2	195,74
JMP8	-		M3 - M4 - M5 - M6 M8 - M10 - M12		-	160,87	JMPT8	177,18
JMP4	-		M3 - M4 - M5 - M6 M8 - M10 - M12		2.5 / 3.3 / 4.2 / 5.0 6.8 / 8.5 / 10.2 mm	195,74	JMPT4	212,16



INOX

## CONTENIDO

	FORMA B	OX	 35°	OX	 HSSCo 5%	HSS PM €		TiN €
JMX6	M3 - M4 - M5 - M6 M8 - M10 - M12		-		-	143,90	JMXT6	156,97
JMX2	M3 - M4 - M5 - M6 M8 - M10 - M12		-		2.5 / 3.3 / 4.2 / 5.0 6.8 / 8.5 / 10.2 mm	178,77	JMXT2	191,85
JMX8	-		M3 - M4 - M5 - M6 M8 - M10 - M12		-	164,22	JMXT8	181,04
JMX4	-		M3 - M4 - M5 - M6 M8 - M10 - M12		2.5 / 3.3 / 4.2 / 5.0 6.8 / 8.5 / 10.2 mm	199,08	JMXT4	215,90

  
1200  
N/mm<sup>2</sup>

## CONTENIDO

	FORMA B	OX	 35°	OX	 HSSCo 5%	HSS V3 €		TINALOX €
JMMD6	M3 - M4 - M5 - M6 M8 - M10 - M12		-		-	130,80	JMMDT6	185,70
JMMD2	M3 - M4 - M5 - M6 M8 - M10 - M12		-		2.5 / 3.3 / 4.2 / 5.0 6.8 / 8.5 / 10.2 mm	165,67	JMMDT2	220,56
JMMD8	-		M3 - M4 - M5 - M6 M8 - M10 - M12		-	149,28	JMMDT8	214,13
JMMD4	-		M3 - M4 - M5 - M6 M8 - M10 - M12		2.5 / 3.3 / 4.2 / 5.0 6.8 / 8.5 / 10.2 mm	184,14	JMMDT4	248,99

**MACHOS DE MÁQUINA EN ESTUCHES METÁLICOS**



Ref. JMC2

**CONTENIDO**

	FORMA B	TiCN	15°	TiCN	HSSCo 5%	HSS-PM €
JMC6	M3 - M4 - M5 - M6 M8 - M10 - M12		-		-	222,51
JMC2	M3 - M4 - M5 - M6 M8 - M10 - M12		-		2.5 / 3.3 / 4.2 / 5.0 6.8 / 8.5 / 10.2 mm	257,38
JMC8	-		M3 - M4 - M5 - M6 M8 - M10 - M12		-	253,27
JMC4	-		M3 - M4 - M5 - M6 M8 - M10 - M12		2.5 / 3.3 / 4.2 / 5.0 6.8 / 8.5 / 10.2 mm	288,14

**TODO TERRENO**

**CONTENIDO**

	FORMA B	TiN	35°	TiN	HSSCo 5%	HSSCo 5% €
JMD6	M3 - M4 - M5 - M6 M8 - M10 - M12		-		-	201,08
JMD2	M3 - M4 - M5 - M6 M8 - M10 - M12		-		2.5 / 3.3 / 4.2 / 5.0 6.8 / 8.5 / 10.2 mm	235,94
JMD8	-		M3 - M4 - M5 - M6 M8 - M10 - M12		-	226,75
JMD4	-		M3 - M4 - M5 - M6 M8 - M10 - M12		2.5 / 3.3 / 4.2 / 5.0 6.8 / 8.5 / 10.2 mm	261,62

**AI**

**CONTENIDO**

	DIENTE ALTERNO	BRILLANTE	2 CANALES	BRILLANTE	HSS	HSSCo 5% €
JMAL6	M3 - M4 - M5 - M6 M8 - M10 - M12		-		-	159,21
JMAL2	M3 - M4 - M5 - M6 M8 - M10 - M12		-		2.5 / 3.3 / 4.2 / 5.0 6.8 / 8.5 / 10.2 mm	194,07
JMAL8	-		M3 - M4 - M5 - M6 M8 - M10 - M12		-	157,43
JMAL4	-		M3 - M4 - M5 - M6 M8 - M10 - M12		2.5 / 3.3 / 4.2 / 5.0 6.8 / 8.5 / 10.2 mm	192,30

**MACHOS DE MÁQUINA EN ESTUCHES**
**USO  
GENERAL**
**CONTENIDO**

	FORMA B	BRILLANTE	 35°	BRILLANTE	HSSCo 5% €
PT01	M4 - M5 - M6 M8 - M10		M4 - M5 - M6 M8 - M10		122,11



Ref. PT01

**Plus**
**CONTENIDO**

	FORMA B	BRILLANTE	 35°	BRILLANTE	HSS PM €	TiN €
PT02	M4 - M5 - M6 M8 - M10		M4 - M5 - M6 M8 - M10		153,61	225,59
PT03						



Ref. PT03

**INOX**
**CONTENIDO**

	FORMA B	OX	 35°	OX	HSS PM €	TiN €
PT05	M4 - M5 - M6 M8 - M10		M4 - M5 - M6 M8 - M10		201,84	214,80
PT13						



Ref. PT05

**CONTENIDO**

	FORMA B	OX	 35°	OX	HSS V3 €	TINALOX €
PT04	M4 - M5 - M6 M8 - M10		M4 - M5 - M6 M8 - M10		173,22	260,31
PT14						



Ref. PT04

**CONTENIDO**

	FORMA B	TiCN	 15°	TiCN	HSS PM €
PT11	M4 - M5 - M6 M8 - M10		M4 - M5 - M6 M8 - M10		313,81



Ref. PT11

**MACHOS DE MÁQUINA EN ESTUCHES**



Ref. PT06

**CONTENIDO**

	DIENTE ALTERNO	2 CANALES	HSSCo 5% €
PT06	M4 - M5 - M6 M8 - M10	M4 - M5 - M6 M8 - M10	191,50



Ref. PT07

**CONTENIDO**

	FORMA C	HSSCo 5% €
PT07	M4 - M5 - M6 - M8 - M10 M4 - M5 - M6 - M8 - M10	144,73



Ref. PT10

**CONTENIDO**

	FORMA C	HSSCo 5% €
PT10	M4 - M5 - M6 - M8 - M10 M4 - M5 - M6 - M8 - M10	175,93



Ref. PT08

**CONTENIDO**

		HSSCo 5% €
PT08	M4 - M5 - M6 - M8 - M10 M4 - M5 - M6 - M8 - M10	264,88



Ref. PT09

**CONTENIDO**

		HSSCo 5% €
PT09	M4 - M5 - M6 - M8 - M10 M4 - M5 - M6 - M8 - M10	356,84



Ref. PT12

**CONTENIDO**

	FORMA B	35°	HSSCo 5% €
PT12	M4 - M5 - M6 M8 - M10	M4 - M5 - M6 M8 - M10	197,88



**EXPOSITORES DE METACRILATO PARA MACHOS DE MÁQUINA**
**EXPOSITOR DE METACRILATO**

MM-03

Composición: Machos de máquina, Serie Normal

**HSSCo**  
**5%**
**FORMA**

Agujeros pasantes, Ref. M2

**B**

<u>M4</u>	<u>M5</u>	<u>M6</u>	<u>M8</u>	<u>M10</u>	<u>M12</u>	<u>M14</u>
5	10	10	10	10	5	4



35°

Agujeros ciegos, Ref. M4

<u>M4</u>	<u>M5</u>	<u>M6</u>	<u>M8</u>	<u>M10</u>	<u>M12</u>	<u>M14</u>
5	10	10	10	10	5	4

Dimensiones: ancho 240 x fondo 240 x alto 245 mm

1.878,82 €



Ref. MM-03



Ref. MM-04

**EXPOSITOR DE METACRILATO**

MM-04

Composición: Machos de máquina, Serie Plus  
Fabricados en Acero sinterizado PM
**HSS**  
**PM**
*Plus*
**FORMA**

Agujeros pasantes, Ref. M2

**B**

<u>M4</u>	<u>M5</u>	<u>M6</u>	<u>M8</u>	<u>M10</u>	<u>M12</u>	<u>M14</u>
5	10	10	10	10	5	4



35°

Agujeros ciegos, Ref. M4

<u>M4</u>	<u>M5</u>	<u>M6</u>	<u>M8</u>	<u>M10</u>	<u>M12</u>	<u>M14</u>
5	10	10	10	10	5	4

Dimensiones: ancho 240 x fondo 240 x alto 245 mm

2.458,17 €

**EXPOSITOR DE METACRILATO**

MM-05

Composición: Machos de máquina para trabajos especiales

**FORMA**
**B**

Agujeros pasantes, Ref. M2

1200  
N/mm<sup>2</sup>

<u>M4</u>	<u>M5</u>	<u>M6</u>	<u>M8</u>	<u>M10</u>	<u>M12</u>	<u>M14</u>
1	2	2	2	2	1	1

**INOX**

<u>M4</u>	<u>M5</u>	<u>M6</u>	<u>M8</u>	<u>M10</u>	<u>M12</u>	<u>M14</u>
1	2	2	2	2	1	1

**Al**

<u>M4</u>	<u>M5</u>	<u>M6</u>	<u>M8</u>	<u>M10</u>	<u>M12</u>	<u>M14</u>
1	2	2	2	2	1	1

**TiN**

<u>M4</u>	<u>M5</u>	<u>M6</u>	<u>M8</u>	<u>M10</u>	<u>M12</u>	<u>M14</u>
1	2	2	2	2	1	1

1400  
N/mm<sup>2</sup>

<u>M4</u>	<u>M5</u>	<u>M6</u>	<u>M8</u>	<u>M10</u>	<u>M12</u>
1	2	2	2	2	1



35°

Agujeros ciegos, Ref. M4

1200  
N/mm<sup>2</sup>

<u>M4</u>	<u>M5</u>	<u>M6</u>	<u>M8</u>	<u>M10</u>	<u>M12</u>	<u>M14</u>
1	2	2	2	2	1	1

**INOX**

<u>M4</u>	<u>M5</u>	<u>M6</u>	<u>M8</u>	<u>M10</u>	<u>M12</u>	<u>M14</u>
1	2	2	2	2	1	1

**Al**

<u>M4</u>	<u>M5</u>	<u>M6</u>	<u>M8</u>	<u>M10</u>	<u>M12</u>	<u>M14</u>
1	2	2	2	2	1	1

**TiN**

<u>M4</u>	<u>M5</u>	<u>M6</u>	<u>M8</u>	<u>M10</u>	<u>M12</u>	<u>M14</u>
1	2	2	2	2	1	1

1400  
N/mm<sup>2</sup>

<u>M4</u>	<u>M5</u>	<u>M6</u>	<u>M8</u>	<u>M10</u>	<u>M12</u>
1	2	2	2	2	1

Dimensiones: ancho 240 x fondo 240 x alto 245 mm

3.215,54 €