



**75** YEARS  
1947-2022

**Taladrado**   
**Perçage**  
**Drilling**  
**Bohren**

**Herç** / CUTTING  
TOOL  
EXPERTS

Brocas Metal Duro / Forets Carbure / Hard Metal Drill-bits / Hartmetall-Bohrer									
1175	HM-MD	DIN 6537 S	TIALN		3XD    DIN 6535	P M K S	24		
1176	HM-MD	DIN 6537 S	TIALN		3XD	P M K S H	25		
1177	HM-MD	DIN 6537 L	TIALN		5XD	P M K S H	26		
1178	HM-MD	DIN 6537 EL	TIALN		8XD	P M K S H	27		
1184	HM-MD		TIALN		12XD	P M K S	28		
1182	HM-MD		TIN		1XD	H	28		
1120	HM-MD	DIN 6539			2XD	P M K N S	29		
1109	HM-MD	DIN 338N			4XD	P M K N S	30		

Brocas con mango cilíndrico cortas / Forets à queue cylindrique courtes / Short straight shank drill-bits / Kurzer Zylinderschaft-Bohrer (DIN 338)									
1101	HSS	DIN338N				P K N	31		
1101/1	HSS	DIN338N				P K N	33		
1104	HSS	DIN338N				P K N	33		
1104/9	HSS	ANSI				P K N	34		
1501	HSS					P K N	34		
1158	HSS	DIN338NSP				P K N	35		
1158/9	HSS	DIN338NSP				P K N	36		
1108	HSS	DIN338NSP	TIN			P K N	37		
1103	HSS	DIN338H				N	38		
1105	HSSCO	DIN 338N				P K N	39		

Brocas con mango cilíndrico cortas / Forets à queue cylindrique courtes / Short straight shank drill-bits / Kurzer Zylinderschaft-Bohrer (DIN 338)									
1105/9	HSSCO	DIN 338N				P N	K		40
1161	HSSCO	DIN338N	TIALN			P N	K		41
1107	HSSCO	DIN338N				P N	K		41
1107/9	HSSCO	ANSI				P N	K		42
1187	HSSCO	DIN338W				P N	M S		43
1106	HSSCO	DIN338W				M S	N		44
1162	HSSCO	DIN338W	TIALN			M S	N		45
1159	HSSCO	DIN338S				P	N		46
1160	HSSCO	DIN338S	TIALN			P	N		47
1110	WIDIA	DIN338N				P N	K		48

Brocas con mango cilíndrico largos / Forets à queue cylindrique longues / Long straight shank drill-bits / Langer Zylinderschaft-Bohrer									
1112	HSS	DIN 340 N				P N	K		49
1113	HSSCO	DIN 340 N				P N	K		50
1114	HSSCO	DIN 340 S				P	N		51
1164	HSSCO	DIN 340 S	TIALN			P	N		52

Brocas con mango cilíndrico extra largos / Forets à queue cylindrique extra longues / Extra-long straight shank drill-bits / Bohrer mit extra langem Zylinderschaft (DIN 1869)									
1115	HSS	DIN 1869 N				P N	K		53
1165	HSSCO	DIN 1869 S				P	N		54

Brocas con mango cilíndrico extra cortas / Forets à queue cylindrique extra-courtes / Extra-short straight shank drill-bits / Bohrer mit extra kurzem Zylinderschaft (DIN 1897)						
1116	HSS	DIN 1897 N			P, K, N	55
1117	HSS	DIN 1897 N			P, K, N	56
1118	HSSCO	DIN 1897 N			P, K, N	56
1166	HSSCO	DIN 1897 S			P, N	57
1167	HSSCO	DIN 1897 S			P, N	58

Brocas con mango cónico / Forets à queue conique / Taper straight shank drill-bits / Konischer Schaftbohrer						
1121	HSS	DIN 345 N			P, K, N	59
1121/9	HSS	DIN 345 N			P, K, N	61
1123	WIDIA	DIN 345 N			P, K	62
1122	HSSCO	DIN 345 N			P, K, N	63
1181	HSSCO				P, S, H	64
1125	HSS	DIN 341 N			P, K, N	65
1126	HSS	DIN 1870 N			P, K, N	66
1139	HSS	DIN 343			P, K, N	67

Brocas bidiametrales / Forets biétagés / Two-diameter drill-bits / Mehrfasen-Stufenbohrer						
1127	HSS	DIN 8376			P, K, N	68
1128	HSS	DIN 8374			P, K, N	68
1129	HSS	DIN 8377			P, K, N	69
1130	HSS	DIN 8375			P, K, N	69

**Brocas bidiametrales / Forets biétagés / Two-diameter drill-bits / Mehrfasen-Stufenbohrer**





1152	HSS	DIN 8378				P, K N	70
1153	HSS	DIN 8379				P, K N	70
1191	HSSCO					P, M, K N, S	71
1192	HSSCO					P, M, K N, S	71

**Brocas de centrar / Forets à centrer / Centre drill-bits / Zentrierbohrer**













1132	HSS	DIN 333 A			  	P, K N	72
1188	HSS	DIN 333 A	TiN		  	P, K N	72
1193	HM-MD	DIN 333 A			  	P, M, K N, S, H	73
1133	HSS	DIN 333 A			  	P, K N	73
1135	HSS	DIN 333 R			  	P, K N	74
1137	HSS	DIN 333 B			  	P, K N	74
1138	HSSCO				  	P, M, K N, S	75
1155	HSSCO				  	P, M, K N, S	75
1189	HSSCO		TiN		  	P, M, K N, S	76
1190	HSSCO		TiN		  	P, M, K N, S	76
1179	HM-MD				1XD  DIN 6535 HA	P, M, K N, S	77
1180	HM-MD				1XD  DIN 6535 HA	P, M, K N, S	77
1185	HM-MD		TiAlN		1XD  DIN 6535 HA	P, M, K N, S	78
1186	HM-MD		TiAlN		1XD  DIN 6535 HA	P, M, K N, S	78



1119	HSSCO	DIN 1897N				P	79
1194	HSSCO	DIN 1897N	TiAlN			P	79

**Brocas fresa / Forets fraiseur / Mill drills / Fräsbohrer**

5114	HSS					P N	80
5115	HSS		TiN			P N	80

**Accesorios / Accessoires / Accessories/ Zubehör**

6110	<b>Espiga /</b> Queue à tenon / Bit shank / Stift						81
6111	<b>Casquillo DIN 2185 /</b> Douille de réduction / Drill sleeve / Bohrerhülse						81
6114	<b>Contrapunto /</b> Contrepointe / Fixed centre / Reitstock						81
6112	<b>Alargadera /</b> Adaptateur / Extension piece / Verlängerungsstück						82
6113	<b>Expulsor /</b> Éjecteur / Ejector / Auswerfer						82
6115	<b>Punto giratorio /</b> Pointe tournante / Revolving lathe centre / Mittlaufende Drehbankspitze						82
6101	HP1						83
6120	HP1-CM						83
6102	HP2						84
6103	HP3						84
6122	<b>Afilador de Brocas /</b> Affûteuses forets / Twist Drill Sharpener / Bohrschärfer						85
6123	<b>Porta /</b> Mandrins / Chuck / Bohrfutter						85
6124	<b>Muela /</b> Meule / Wheel / Schleifscheibe						85

<b>Estuches / Coffrets / Sets / Hüllen</b>			86
<b>Expositores / Presentoirs / Displays / Verkaufsständer</b>			90



# FORMULARIO BROCAS ESPECIALES

## FICHE TECHNIQUE FORETS SPECIAUX / TECHNICAL ENQUIRY FOR SPECIAL DRILL BITS / SPEZIALBOHRER-FORMULAR

Fecha / Date: .....

Empresa / Entreprise / Company: ..... Contacto / Contact: .....

Dirección / Adresse / Address: ..... Población / Ville / Town: .....

Tel / Fax: ..... E-mail: .....

### TRABAJO A REALIZAR / TRAVAIL DEMANDE / REQUESTED WORK

Material / Matière / Material ..... Norma / Norme / Norm: .....

Dureza / Durété / Hardness ..... HB ..... HRc Resistencia / Résistance / Resistance ..... N/mm<sup>2</sup>

Tipo viruta:  Corta  Larga  Polvo  
 Type copeau Courte Longue Poussière  
 Shaving Short Long Powder

Máquina / Machine ..... Refrigerante / Réfrigérant / Coolant .....

Posición / Position  Horizontal  Vertical  V. Corte  V. avance  
 V. Coupe Avance  
 Cutting Speed Feed

### HERRAMIENTA / OUTIL / TOOL

Descripción / Description ..... Cantidad / Quantité / Quantity .....

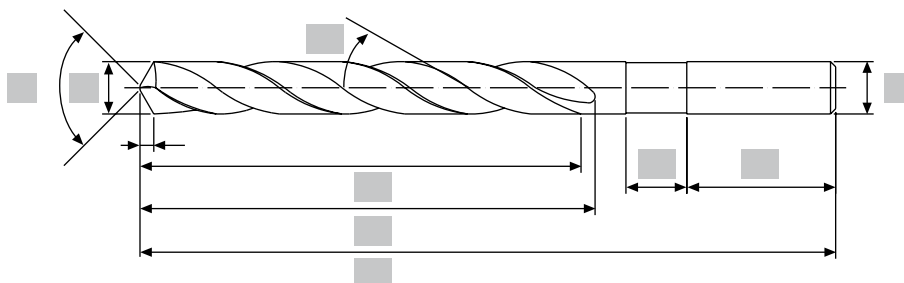

Mango:  Cilíndrico  Weldon  Cónico  Rebajado  
 Queue: Cylindrique Weldon Conique Réduite  
 Shank: Straight Weldon Taper Reduced

Afilado:  Convencional  Corrección de labios  Split Point  Puntos soldadura  Placa carburo  
 Affûtage: Normal Correction de lèvres Affûtage en croix Points de soudure plaquelette carbure  
 Sharpened: Convencional Lip correction Split Point Welding points Carbide sheet

Material / Matière / Material:  HSS  HSSE  HM  HSS-HM

Superficie / Surface:  Brillante  Negra  Recubrimiento  
 Brillant Noire Revêtement  
 Brilliant Black Coating

COMENTARIOS / COMMENTAIRES/ COMMENTS: .....



# TABLA DE APLICACIONES GUIDE D'APPLICATION / APPLICATION GUIDE / ANWENDUNGSÜBERSICHT



$$r.p.m. = \frac{Vc \times 1.000}{\pi \times \phi}$$

Ref./ Réf. / Ref.	1175	1176	1177	1178	1184	1182	1120	1109
Prof./ Prof./Depth	3xd	3xd	5xd	8xd	12xd	1Xd	2xd	4xd
Punta/Poin/Point	140°	140°	140°	140°	140°	120°	118°	118°
Refrig./Réfrig./Cooling	No	Si	Si	Si	Si	No	No	No
Mat.	HM	HM	HM	HM	HM	HM	HM	HM
Rec./Rev./Coat.	TIALN	TIALN	TIALN	TIALN	TIALN	TIN		
DIN	6537S	6537S	6537L	6537L	-	-	6539	338
Gama/Gamme/Range	3-20	3-20	3-20	3-16	3-16	M3-M12	2-13	2-10,20
Pag.	24	25	26	27	28	28	29	30

Mat.	Avance/Feed (mm/rpm)						Vc (m/min)						
	Ø2	Ø5	Ø10	Ø15	Ø20								
P.1	<600	0.10-0.14	0.20-0.28	0.30-0.45	0.38-0.55	0.48-0.68	0 80-110	0 90-120	0 90-120	0 90-120	0 70-90	0 40-70	0 40-70
P.2	<800	0.08-0.12	0.16-0.24	0.25-0.38	0.32-0.48	0.40-0.60	0 40-80	0 50-90	0 50-90	0 50-90	0 40-80	0 30-60	0 30-60
P.3	<1000	0.06-0.10	0.12-0.20	0.20-0.32	0.25-0.40	0.30-0.50	0 35-75	0 40-85	0 40-85	0 40-85	0 35-55	0 25-50	0 25-50
P.4	<1200	0.04-0.08	0.08-0.16	0.12-0.26	0.15-0.32	0.18-0.40	0 30-50	0 35-55	0 35-55	0 35-55	0 30-50	0 20-40	0 20-40
P.5	<1400	0.03-0.06	0.06-0.12	0.08-0.20	0.10-0.25	0.12-0.30	0 25-40	0 30-45	0 30-45	0 30-45	0 25-40	0 15-25	0 15-25
M.1	<950	0.04-0.08	0.08-0.16	0.12-0.26	0.15-0.32	0.18-0.40	0 35-75	0 40-85	0 40-85	0 40-85	0 35-55	0 20-25	0 20-25
M.2		0.04-0.08	0.08-0.16	0.12-0.26	0.15-0.32	0.18-0.40	0 35-75	0 40-85	0 40-85	0 40-85	0 35-55	0 20-25	0 20-25
M.3	<1200	0.03-0.06	0.06-0.12	0.08-0.20	0.10-0.25	0.12-0.30	0 35-55	0 35-55	0 35-55	0 35-55	0 35-55	0 20-25	0 20-25
M.4		0.03-0.06	0.06-0.12	0.08-0.20	0.10-0.25	0.12-0.30	0 30-45	0 30-45	0 30-45	0 30-45	0 30-45	0 20-25	0 20-25
K.1	<500	0.08-0.12	0.16-0.24	0.25-0.38	0.32-0.48	0.40-0.60	0 100-130	0 120-150	0 120-150	0 120-150	0 90-120	0 50-70	0 50-70
K.2		0.08-0.12	0.16-0.24	0.25-0.38	0.32-0.48	0.40-0.60	0 60-80	0 70-90	0 70-90	0 70-90	0 60-80	0 40-50	0 40-50
K.3	<800	0.06-0.10	0.12-0.20	0.20-0.32	0.25-0.40	0.30-0.50	0 80-110	0 90-120	0 90-120	0 90-120	0 70-90	0 40-50	0 40-50
K.4.1		0.06-0.10	0.12-0.20	0.20-0.32	0.25-0.40	0.30-0.50	0 70-90	0 80-110	0 80-110	0 80-110	0 60-80	0 40-50	0 40-50
K.4.2	<1400	0.03-0.06	0.06-0.12	0.08-0.20	0.10-0.25	0.12-0.30	0 40-60	0 50-70	0 50-70	0 50-70	0 30-50	0 40-50	0 40-50
N.1.1	Al	0.08-0.12	0.16-0.24	0.25-0.38	0.32-0.48	0.40-0.60						0 100-140	0 100-140
N.1.2		0.08-0.12	0.16-0.24	0.25-0.38	0.32-0.48	0.40-0.60						0 70-100	0 70-100
N.1.3		0.08-0.12	0.16-0.24	0.25-0.38	0.32-0.48	0.40-0.60						0 60-80	0 60-80
N.2.1	Cu	0.06-0.10	0.12-0.20	0.20-0.32	0.25-0.40	0.30-0.50						0 40-70	0 40-70
N.2.2		0.06-0.10	0.12-0.20	0.20-0.32	0.25-0.40	0.30-0.50						0 40-70	0 40-70
N.2.3		0.06-0.10	0.12-0.20	0.20-0.32	0.25-0.40	0.30-0.50						0 30-60	0 30-60
N.2.4		0.04-0.08	0.08-0.16	0.12-0.26	0.15-0.32	0.18-0.40						0 25-50	0 25-50
N.3.1	Mg/Zn	0.06-0.10	0.12-0.20	0.20-0.32	0.25-0.40	0.30-0.50						0 30-60	0 30-60
N.4.1	Plastic	0.06-0.10	0.12-0.20	0.20-0.32	0.25-0.40	0.30-0.50						0 40-70	0 40-70
N.4.2													
N.4.3													
S.1.1	Ni	0.03-0.05	0.05-0.08	0.08-0.12	0.12-0.16	0.16-0.20	0 20-25	0 25-30	0 25-30	0 25-30	0 20-25	0 10-15	0 10-15
S.1.2		0.03-0.05	0.05-0.08	0.08-0.12	0.12-0.16	0.16-0.20	0 20-25	0 20-25	0 20-25	0 20-25	0 15-20	0 10-15	0 10-15
S.2.1	Ti	0.04-0.08	0.08-0.16	0.12-0.26	0.15-0.32	0.18-0.40	0 35-75	0 40-85	0 40-85	0 40-85	0 40-85	0 15-25	0 15-25
S.2.2		0.03-0.05	0.05-0.08	0.08-0.12	0.12-0.16	0.16-0.20	0 25-35	0 30-40	0 30-40	0 30-40	0 30-40	0 10-15	0 10-15
S.2.3		0.03-0.05	0.05-0.08	0.08-0.12	0.12-0.16	0.16-0.20	0 20-25	0 25-30	0 25-30	0 25-30	0 25-30	0 10-15	0 10-15
H.1	50 HRC	0.03-0.06	0.06-0.12	0.08-0.20	0.10-0.25	0.12-0.30	0 25-35	0 30-40	0 30-40	0 30-40	0 25-30	0 15-25	0 15-25
H.2	55 HRC	0.01-0.04	0.04-0.08	0.06-0.10	0.08-0.12	0.10-0.18	0 15-25	0 20-35	0 20-35	0 20-35	0 15-25	0 10-15	0 10-15
H.3	60 HRC	0.01-0.04	0.04-0.08	0.06-0.10	0.08-0.12	0.10-0.18	0 15-25	0 15-25	0 15-25	0 15-25	0 10-15	0 10-15	0 10-15

● Optima / Optimun ○ Alternativo / Alternative



# TABLA DE APLICACIONES GUIDE D'APPLICATION / APPLICATION GUIDE / ANWENDUNGSÜBERSICHT



$$\text{r.p.m.} = \frac{V_c \times 1.000}{\pi \times \phi}$$

Ref./ Réf. / Ref.	1101	1101/1	1104	1104/9	1501	1158	1158/9	1108	1103	1105	1105/9	1161
DIN	338	338	338	ANSI	338	338	338	338	338	338	338	338
Punta/Poin/Point	118°	118°	118°	118°	118°	118°	118°	118°	118°	135°	135°	135°
Ejec./Exéc./Exec.	N	N	N	N	N	NSP	NSP	NSP	N	NSP	NSP	NSP
Hel./Hél./Spiral	30°	30°-LH	30°	30°	30°	30°	30°	30°	18°	30°	30°	30°
Mat.	HSS	HSS	HSS	HSS	HSS	HSS	HSS	HSS	HSS	HSSCO	HSSCO	HSSCO
Rec./Rev./Coat.								TIN				TIALN
Prof./ Prof./Depth	5xD	5xD	3xD	3xD	5xD	5xD	5xD	5xD	5xD	5xD	5xD	5xD
Gama/Gamme/Range	0,20-20	2-12	10-30	17/32-1"1/8	3-10	1-20	1/16-1/2	1-13	1-13	0,50-20	1/16-1/2	2-13
Pag.	31	33	33	34	34	35	36	37	38	39	40	41

Mat.	Avance/Feed (mm/rpm)					Vc (m/min)												
	Ø2	Ø5	Ø10	Ø15	Ø20	Ø2	Ø5	Ø10	Ø15	Ø20	Ø25	Ø30	Ø35	Ø40	Ø50	Ø60	Ø75	Ø90
P.1	<600	0,04-0,06	0,08-0,12	0,20-0,30	0,30-0,40	0,35-0,46	25-35	25-35	25-35	25-35	25-35	25-35	25-35	35-45	25-35	25-35	35-50	
P.2	<800	0,02-0,06	0,08-0,12	0,12-0,30	0,18-0,40	0,22-0,46	15-30	15-30	15-30	15-30	15-30	15-30	15-30	20-40	15-30	15-30	25-45	
P.3	<1000	0,02-0,03	0,05-0,07	0,12-0,18	0,18-0,24	0,22-0,28								15-30	12-20	12-20	18-30	
P.4	<1200	0,01-0,04	0,04-0,09	0,09-0,18	0,12-0,28	0,14-0,33									6-16	6-16	10-25	
P.5	<1400	0,01-0,04	0,04-0,09	0,09-0,18	0,12-0,28	0,14-0,33												
M.1	<950	0,02-0,04	0,05-0,09	0,18-0,21	0,20-0,28	0,25-0,33											10-14	15-20
M.2		0,01-0,03	0,05-0,07	0,14-0,18	0,20-0,24	0,22-0,28											8-12	12-18
M.3	<1200																	
M.4																		
K.1	<500	0,04-0,06	0,08-0,12	0,20-0,30	0,30-0,40	0,35-0,46	25-30	25-30	25-30	25-30	25-30	25-30	25-30	35-40	25-30	25-30	38-45	
K.2																		
K.3	<800	0,04-0,06	0,08-0,12	0,20-0,30	0,30-0,40	0,35-0,46												
K.4.1		0,04-0,06	0,05-0,09	0,18-0,21	0,20-0,28	0,25-0,33	12-16	12-16	12-16	12-16	12-16	12-16	12-16	15-20	12-16	12-16	18-25	
K.4.2		<1400	0,02-0,04	0,05-0,09	0,18-0,21	0,20-0,28	0,25-0,33											
N.1.1	Al	0,03-0,05	0,08-0,12	0,18-0,24	0,25-0,32	0,30-0,37								75-90				
N.1.2		0,02-0,04	0,05-0,09	0,18-0,21	0,20-0,28	0,25-0,33	50-60	50-60	50-60	50-60	50-60	50-60	50-60	65-75	50-60	50-60	70-80	
N.1.3		0,02-0,04	0,05-0,09	0,18-0,21	0,20-0,28	0,25-0,33												
N.2.1	Cu	0,03-0,05	0,08-0,10	0,18-0,24	0,25-0,32	0,30-0,37									40-60			
N.2.2		0,03-0,05	0,08-0,10	0,18-0,24	0,25-0,32	0,30-0,37									25-60			
N.2.3		0,02-0,04	0,05-0,09	0,18-0,21	0,20-0,28	0,25-0,33	30-60	30-60	30-60	30-60	30-60	30-60	30-60	40-70	30-60	30-60	45-80	
N.2.4																		
N.3.1	Mg/Zn	0,02-0,04	0,05-0,09	0,18-0,21	0,20-0,28	0,25-0,33												
N.4.1	Plastic	0,03-0,04	0,06-0,07	0,12-0,13	0,16-0,17	0,25-0,26	20-25	20-25	20-25	30-35	20-25	20-25	20-25	20-25	20-25	20-25	30-35	
N.4.2		0,03-0,04	0,06-0,07	0,12-0,13	0,16-0,17	0,25-0,26			15-20									
N.4.3																		
S.1.1	Ni	0,01-0,03	0,03-0,05	0,06-0,10	0,10-0,14	0,16-0,20												
S.1.2		0,01-0,03	0,03-0,05	0,06-0,10	0,10-0,14	0,16-0,20												
S.2.1	Ti	0,01-0,03	0,04-0,06	0,08-0,10	0,10-0,14	0,16-0,20												
S.2.2		0,01-0,03	0,03-0,05	0,06-0,10	0,10-0,14	0,16-0,20												
S.2.3		0,01-0,03	0,03-0,05	0,06-0,10	0,10-0,14	0,16-0,20												
H.1	50 HRC	0,02-0,03	0,05-0,07	0,09-0,13	0,14-0,18	0,18-0,22												
H.2	55 HRC																	
H.3	60 HRC																	

● Optima / Optimun ○ Alternativo / Alternative

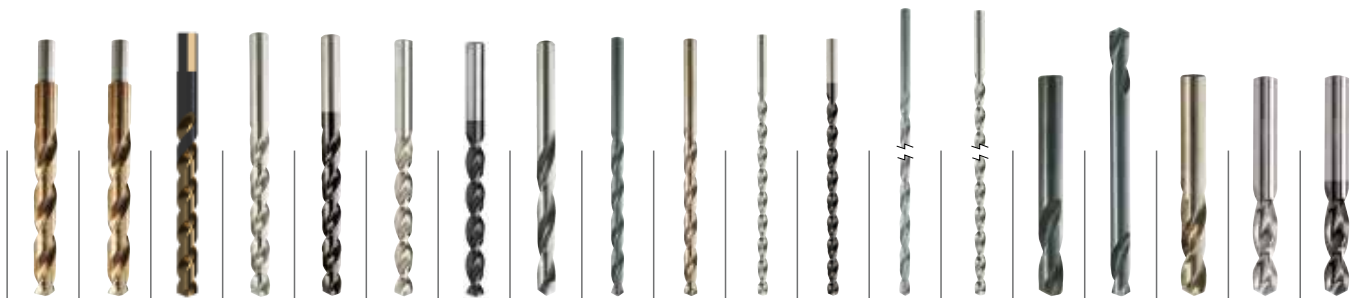

1107	1107/9	1187	1106	1162	1159	1160	1110	1112	1113	1114	1164	1115	1165	1116	1117	1118	1166	1167
338	ANSI	338	338	338	338	338	338	340	340	340	340	1869	1869	1897		1897	1897	1897
135°	135°	135°	135°	135°	135°	135°	118°	118°	135°	135°	135°	118°	135°	118°	118°	135°	135°	135°
NSP	NSP	W	W	W	TS	TS	N	N	NSP	TS	TS	NSP	TS	N	N	NSP	TS	TS
30°	30°	35°	35°	35°	30°	30°	30°	30°	30°	30°	30°	30°	30°	30°	30°	30°	30°	30°
HSSCO	HSSCO	HSSCO	HSSCO	HSSCO	HSSCO	HSSCO	HSS WIDIA	HSS	HSSCO	HSSCO	HSSCO	HSS	HSSCO	HSS	HSS	HSSCO	HSSCO	HSSCO
				TIALN		TIALN						TIALN						TIALN
5xD	3xD	5xD	5xD	5xD	5xD	5xD	5xD	10xD	10xD	10xD	10xD	15-30xD	15-30xD	3xD	3xD	3xD	3xD	3xD
10-20	17/32-13/16	1-13	1-13	1-13	2-13	2-13	1,50-20	1-20	2-13	2-13	2-13	2-13	2-12	1-20	2-8	2-13	2-16	2-16
41	42	43	44	45	46	47	48	49	50	51	52	53	54	55	56	56	57	58

Vc (m/min)

○ 25-35	○ 25-35	● 35-40						● 25-35	○ 25-35			● 25-35		● 25-35	● 25-35	○ 25-35		
● 15-30	● 15-30	● 30-35			● 15-30	● 25-45	● 25-45	● 15-30	● 15-30	● 15-30	● 25-45	● 15-30	● 15-30	● 15-30	● 15-30	● 15-30	● 15-30	● 25-45
● 12-20	● 12-20				● 12-20	● 18-30	● 18-30		● 12-20	● 12-20	● 18-30		● 12-20			● 12-20	● 12-20	● 18-30
● 6-16	● 6-16				● 6-16	● 10-25	● 10-25		● 6-16	● 6-16	● 10-25					● 6-16	● 6-16	● 10-25
								○ 6-9										
○ 10-14	○ 10-14	● 10-14	● 10-14	● 15-20	○ 10-14	○ 15-20			○ 10-14	○ 10-14	○ 15-20		○ 10-14			○ 10-14	○ 10-14	○ 15-20
○ 8-12	○ 8-12	● 8-12	● 8-12	● 12-18	○ 8-12	○ 12-18			○ 8-12	○ 8-12	○ 12-18		○ 8-12			○ 8-12	○ 8-12	○ 12-18
● 25-30	● 25-30							● 25-30	● 25-30			● 25-30		● 25-30	● 25-30	● 25-30	● 25-30	
● 12-16	● 12-16							● 12-16	● 12-16			● 12-16		● 12-16	● 12-16	● 12-16	● 12-16	
							● 15-20											
		○ 60-80	○ 60-80	○ 85-100	○ 60-80	○ 85-100				○ 60-80	○ 85-100		○ 60-80				○ 60-80	○ 85-100
○ 50-60	○ 50-60	○ 50-60	○ 50-60	○ 75-90	○ 50-60	○ 75-90		○ 50-60	○ 50-60	○ 50-60	○ 75-90	○ 50-60	○ 50-60	○ 50-60	○ 50-60	○ 50-60	○ 50-60	○ 75-90
		○ 30-40	○ 30-40	○ 45-60	○ 30-40	○ 45-60				○ 30-40	○ 45-60		○ 30-40					
● 30-60	● 30-60	○ 50-70	○ 50-70					● 30-60	● 30-60			● 30-60		● 30-60	● 30-60	● 30-60	● 30-60	
		○ 50-70	○ 50-70	○ 75-95	○ 50-70	○ 70-90				○ 50-70	○ 70-90		○ 50-70				○ 50-70	○ 70-90
○ 20-25	○ 20-25						○ 30-35	○ 20-25	○ 20-25			○ 20-25		○ 20-25	○ 20-25	○ 20-25	○ 20-25	
		● 8-10	● 8-10	● 12-15														

● Optima / Optimun ○ Alternativo / Alternative

# TABLA DE APLICACIONES GUIDE D'APPLICATION / APPLICATION GUIDE / ANWENDUNGSÜBERSICHT



$$r.p.m. = \frac{Vc \times 1.000}{\pi \times \phi}$$

Ref./ Réf. / Ref.	1121	1121/9	1122	1123	1181	1125	1126	1139
DIN	345	345	345	345	1181	341	1870	343
Punta/Poin/Point	118°	118°	135°	118°	128°	118°	118°	120°
Ejec./Exéc./Exec.	N	N	NSP	N	N	N	N	N
Hel./Hél./Spiral	30°	30°	30°	30°	15°	30°	30°	30°
Mat.	HSS	HSS	HSSCO	HSS WIDIA	HSSCO	HSS	HSS	HSS
Rec./Rev./Coat.								
Prof./ Prof./Depth	5xD	5xD	5xD	5xD	3xD	8xD	10-15xD	5xD
Gama/Gamme/Range	5-80	1/2-2"	10-40	10-30	10-50	5-40	8-50	10-40
Pag.	59	61	62	63	64	65	66	67

Mat.	Avance/Feed (mm/rpm)						Vc (m/min)							
	$\phi 2$	$\phi 5$	$\phi 10$	$\phi 15$	$\phi 20$									
P.1	<600	0,04-0,06	0,08-0,12	0,20-0,30	0,30-0,40	0,35-0,46	• 25-35	• 25-35	• 25-35		• 25-35	• 25-35	• 25-35	
P.2	<800	0,02-0,06	0,08-0,12	0,12-0,30	0,18-0,40	0,22-0,46	• 15-30	• 15-30	• 15-30	• 25-45		• 15-30	• 15-30	• 15-30
P.3	<1000	0,02-0,03	0,05-0,07	0,12-0,18	0,18-0,24	0,22-0,28			○ 12-20	○ 18-30				
P.4	<1200	0,01-0,04	0,04-0,09	0,09-0,18	0,12-0,28	0,14-0,33			○ 6-16	○ 10-25	• 8-10			
P.5	<1400	0,01-0,04	0,04-0,09	0,09-0,18	0,12-0,28	0,14-0,33			○ 6-9	• 6-8				
M.1	<950	0,02-0,04	0,05-0,09	0,18-0,21	0,20-0,28	0,25-0,33			○ 8-12				○ 8-12	
M.2		0,01-0,03	0,05-0,07	0,14-0,18	0,20-0,24	0,22-0,28			○ 10-14				○ 10-14	
M.3	<1200													
M.4														
K.1	<500	0,04-0,06	0,08-0,12	0,20-0,30	0,30-0,40	0,35-0,46	• 25-30	• 25-30	• 25-30			• 25-30	• 25-30	• 25-30
K.2														
K.3	<800	0,04-0,06	0,08-0,12	0,20-0,30	0,30-0,40	0,35-0,46				○ 30-40				
K.4.1		0,04-0,06	0,05-0,09	0,18-0,21	0,20-0,28	0,25-0,33	• 12-16	• 12-16	• 12-16			• 12-16	• 12-16	• 12-16
K.4.2	<1400	0,02-0,04	0,05-0,09	0,18-0,21	0,20-0,28	0,25-0,33				○ 15-20				
N.1.1	Al	0,03-0,05	0,08-0,12	0,18-0,24	0,25-0,32	0,30-0,37								
N.1.2		0,02-0,04	0,05-0,09	0,18-0,21	0,20-0,28	0,25-0,33	○ 50-60	○ 50-60	○ 50-60			○ 50-60	○ 50-60	○ 50-60
N.1.3		0,02-0,04	0,05-0,09	0,18-0,21	0,20-0,28	0,25-0,33								
N.2.1	Cu	0,03-0,05	0,08-0,10	0,18-0,24	0,25-0,32	0,30-0,37								
N.2.2		0,03-0,05	0,08-0,10	0,18-0,24	0,25-0,32	0,30-0,37								
N.2.3		0,02-0,04	0,05-0,09	0,18-0,21	0,20-0,28	0,25-0,33	○ 30-60	○ 30-60	○ 30-60			○ 30-60	○ 30-60	○ 30-60
N.2.4														
N.3.1	Mg/Zn	0,02-0,04	0,05-0,09	0,18-0,21	0,20-0,28	0,25-0,33								
N.4.1	Plastic	0,03-0,04	0,06-0,07	0,12-0,13	0,16-0,17	0,25-0,26	○ 20-25	○ 20-25	○ 20-25	○ 30-35		○ 20-25	○ 20-25	○ 20-25
N.4.2		0,03-0,04	0,06-0,07	0,12-0,13	0,16-0,17	0,25-0,26			○ 15-20					
N.4.3														
S.1.1	Ni	0,01-0,03	0,03-0,05	0,06-0,10	0,10-0,14	0,16-0,20					○ 5-7			
S.1.2		0,01-0,03	0,03-0,05	0,06-0,10	0,10-0,14	0,16-0,20					○ 4-6			
S.2.1	Ti	0,01-0,03	0,04-0,06	0,08-0,10	0,10-0,14	0,16-0,20								
S.2.2		0,01-0,03	0,03-0,05	0,06-0,10	0,10-0,14	0,16-0,20								
S.2.3		0,01-0,03	0,03-0,05	0,06-0,10	0,10-0,14	0,16-0,20								
H.1	50 HRC	0,02-0,03	0,05-0,07	0,09-0,13	0,14-0,18	0,18-0,22					○ 4-6			
H.2	55 HRC													
H.3	60 HRC													

● Optima / Optimun ○ Alternativo / Alternative



A series of horizontal dotted lines spanning the width of the page, providing a template for writing or drawing.

# TABLA DE APLICACIONES GUIDE D'APPLICATION / APPLICATION GUIDE / ANWENDUNGSÜBERSICHT

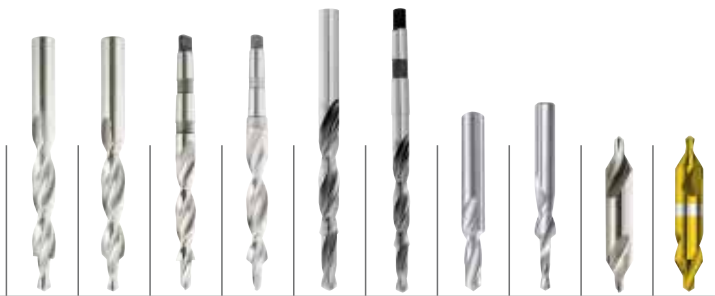

$$r.p.m. = \frac{Vc \times 1.000}{\pi \times \phi}$$

Ref./ Réf. / Ref.	1127	1128	1129	1130	1152	1153	1191	1192	1132	1188
DIN	8376	8374	8377	8375	8378	8379			333	333
Punta/Poin/Point	180°	90°	180°	90°	90°	90°	90°	90°	60°	60°
Ejec./Exéc./Exec.									A	A
Hel./Hél./Spiral										
Mat.	HSS	HSS	HSS	HSS	HSS	HSS	HSSCo	HSSCo	HSS	HSS
Rec./Rev./Coat.										TIN
Prof./ Prof./Depth										
Gama/Gamme/Range	M3-M10	M3-M10	M8-M20	M5-M10	M3-M12	M8-M20	M3-M12	M4-M10	1-12,5	1-12
Pag.	68	68	69	69	70	70	71	71	72	72

Avance/Feed (mm/rpm) HSS/HSSCo - HM=x2							Vc (m/min)																	
Mat.	Ø2	Ø5	Ø10	Ø15	Ø20		●	●	●	●	●	●	●	●	●	●	●	●	●	●	●	●	●	●
P.1	<600	0.04-0.06	0.08-0.12	0.20-0.30	0.30-0.40	0.35-0.46	20-25	20-25	20-25	20-25	20-25	20-25	20-25	20-25	20-25	20-25	20-25	20-25	20-25	20-25	20-25	20-25	20-25	35-40
P.2	<800	0.02-0.06	0.08-0.12	0.12-0.30	0.18-0.40	0.22-0.46	15-20	15-20	15-20	15-20	15-20	15-20	15-20	15-20	15-20	20-25	20-25	20-25	20-25	20-25	20-25	20-25	20-25	30-35
P.3	<1000	0.02-0.03	0.05-0.07	0.12-0.18	0.18-0.24	0.22-0.28	8-10	8-10	8-10	8-10	8-10	8-10	8-10	8-10	8-10	12-18	12-18	12-18	12-18	12-18	12-18	12-18	12-18	12-16
P.4	<1200	0.01-0.04	0.04-0.09	0.09-0.18	0.12-0.28	0.14-0.33										0	0	0	0	0	0	0	0	0
P.5	<1400	0.01-0.04	0.04-0.09	0.09-0.18	0.12-0.28	0.14-0.33																		
M.1	<950	0.02-0.04	0.05-0.09	0.18-0.21	0.20-0.28	0.25-0.33										4-10	4-10	4-10	4-10	4-10	4-10	4-10	4-10	4-10
M.2	<950	0.01-0.03	0.05-0.07	0.14-0.18	0.20-0.24	0.22-0.28										4-10	4-10	4-10	4-10	4-10	4-10	4-10	4-10	4-10
M.3	<1200	0.03-0.04	0.04-0.06	0.08-0.10	0.12-0.14	0.16-0.18																		
M.4	<1200	0.02-0.03	0.03-0.05	0.06-0.08	0.10-0.12	0.14-0.16																		
K.1	<500	0.04-0.06	0.08-0.12	0.20-0.30	0.30-0.40	0.35-0.46	30-35	30-35	30-35	30-35	30-35	30-35	30-35	30-35	30-35	20-25	20-25	20-25	20-25	20-25	20-25	20-25	20-25	30-35
K.2	<500	0.04-0.06	0.08-0.12	0.20-0.30	0.30-0.40	0.35-0.46	30-35	30-35	30-35	30-35	30-35	30-35	30-35	30-35	30-35	20-25	20-25	20-25	20-25	20-25	20-25	20-25	20-25	30-35
K.3	<800	0.04-0.06	0.08-0.12	0.20-0.30	0.30-0.40	0.35-0.46	25-30	25-30	25-30	25-30	25-30	25-30	25-30	25-30	25-30	10-15	10-15	10-15	10-15	10-15	10-15	10-15	10-15	20-30
K.4.1	<800	0.04-0.06	0.05-0.09	0.18-0.21	0.20-0.28	0.25-0.33	25-30	25-30	25-30	25-30	25-30	25-30	25-30	25-30	25-30	10-15	10-15	10-15	10-15	10-15	10-15	10-15	10-15	20-30
K.4.2	<1400	0.02-0.04	0.05-0.09	0.18-0.21	0.20-0.28	0.25-0.33	14-18	14-18	14-18	14-18	14-18	14-18	14-18	14-18	14-18	14-18	14-18	14-18	14-18	14-18	14-18	14-18	14-18	14-18
N.1.1	Al	0.03-0.05	0.08-0.12	0.18-0.24	0.25-0.32	0.30-0.37										50-80	50-80	50-80	50-80	50-80	50-80	50-80	50-80	50-80
N.1.2	Al	0.02-0.04	0.05-0.09	0.18-0.21	0.20-0.28	0.25-0.33										30-50	30-50	30-50	30-50	30-50	30-50	30-50	30-50	30-50
N.1.3	Al	0.02-0.04	0.05-0.09	0.18-0.21	0.20-0.28	0.25-0.33	20-25	20-25	20-25	20-25	20-25	20-25	20-25	20-25	20-25	15-30	15-30	15-30	15-30	15-30	15-30	15-30	15-30	20-30
N.2.1	Cu	0.03-0.05	0.08-0.10	0.18-0.24	0.25-0.32	0.30-0.37										25-35	25-35	25-35	25-35	25-35	25-35	25-35	25-35	25-35
N.2.2	Cu	0.03-0.05	0.08-0.10	0.18-0.24	0.25-0.32	0.30-0.37	30-35	30-35	30-35	30-35	30-35	30-35	30-35	30-35	30-35	40-60	40-60	40-60	40-60	40-60	40-60	40-60	40-60	35-40
N.2.3	Cu	0.02-0.04	0.05-0.09	0.18-0.21	0.20-0.28	0.25-0.33	30-35	30-35	30-35	30-35	30-35	30-35	30-35	30-35	30-35	30-50	30-50	30-50	30-50	30-50	30-50	30-50	30-50	30-50
N.2.4	Cu	0.02-0.04	0.05-0.09	0.18-0.21	0.20-0.28	0.25-0.33																		
N.3.1	Mg/Zn	0.02-0.04	0.05-0.09	0.18-0.21	0.20-0.28	0.25-0.33										60-90	60-90	60-90	60-90	60-90	60-90	60-90	60-90	60-90
N.4.1	Plastic	0.03-0.04	0.06-0.07	0.12-0.13	0.16-0.17	0.25-0.26	15-20	15-20	15-20	15-20	15-20	15-20	15-20	15-20	20-25	35-70	35-70	35-70	35-70	35-70	35-70	35-70	35-70	10-15
N.4.2	Plastic	0.03-0.04	0.06-0.07	0.12-0.13	0.16-0.17	0.25-0.26										12-24	12-24	12-24	12-24	12-24	12-24	12-24	12-24	12-24
N.4.3	Plastic	0.03-0.04	0.06-0.07	0.12-0.13	0.16-0.17	0.25-0.26																		
S.1.1	Ni	0.01-0.03	0.03-0.05	0.06-0.10	0.10-0.14	0.16-0.20										0	0	0	0	0	0	0	0	0
S.1.2	Ni	0.01-0.03	0.03-0.05	0.06-0.10	0.10-0.14	0.16-0.20										0	0	0	0	0	0	0	0	0
S.2.1	Ti	0.01-0.03	0.04-0.06	0.08-0.10	0.10-0.14	0.16-0.20										6-10	6-10	6-10	6-10	6-10	6-10	6-10	6-10	6-10
S.2.2	Ti	0.01-0.03	0.03-0.05	0.06-0.10	0.10-0.14	0.16-0.20										0	0	0	0	0	0	0	0	0
S.2.3	Ti	0.01-0.03	0.03-0.05	0.06-0.10	0.10-0.14	0.16-0.20										0	0	0	0	0	0	0	0	0
H.1	50 HRC	0.02-0.03	0.05-0.07	0.09-0.13	0.14-0.18	0.18-0.22																		
H.2	55 HRC	0.02-0.03	0.05-0.07	0.09-0.13	0.14-0.18	0.18-0.22																		
H.3	60 HRC	0.02-0.03	0.05-0.07	0.09-0.13	0.14-0.18	0.18-0.22																		

● Optima / Optimun ○ Alternativo / Alternative

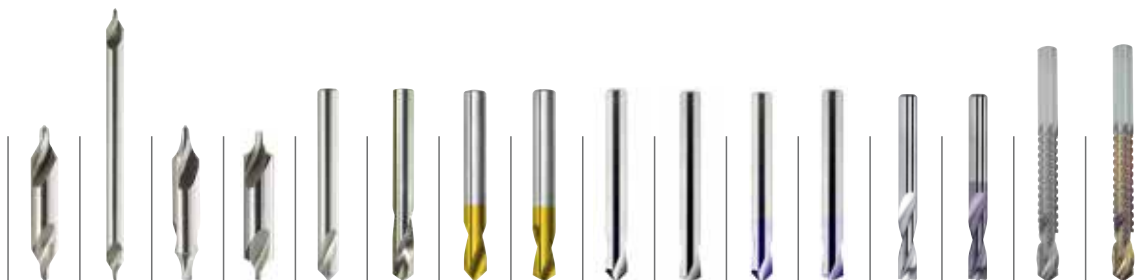

1193	1133	1135	1137	1138	1155	1189	1190	1179	1180	1185	1186	1119	1194	5114	5115
333	333	333	333	CNC	CNC	CNC	CNC	CNC	CNC	CNC	CNC	1897	1897		
60°	60°	Radial	60°-120°	90°	120°	90°	120°	90°	120°	90°	120°	168°-172°	168°-172°	118°	118°
A	A	R	B												
												30°	30°		
HM	HSS	HSS	HSS	HSSCo	HSSCo	HSSCo	HSSCo	HM	HM	HM	HM	HSSCo	HSSCo	HSS	HSS
						TIN	TIN			TIAlN	TIAlN		TIAlN		TIN
1-6,30	1-5	1-12,5	1-6,30	3-20	3-20	3-20	3-20	6-12	6-12	6-12	6-12	6-10	6-10	6-8	6-8
73	73	74	74	75	75	76	76	77	77	78	78	79	79	80	80
Vc (m/min)															
○ 55-60	● 20-30	● 20-30	● 20-30	● 20-30	● 20-30	● 35-40	● 35-40	● 60-80	● 60-80	● 80-100	● 80-100	○ 25-30	○ 35-40	● 20-25	● 25-35
○ 45-60	○ 20-25	○ 20-25	○ 20-25	○ 20-25	○ 20-25	○ 30-35	○ 30-35	○ 55-70	○ 55-70	○ 70-90	○ 70-90	○ 20-25	○ 30-35	○ 10-15	○ 15-20
● 40-55	● 8-12	● 8-12	● 8-12	● 8-12	● 8-12	● 12-16	● 12-16	● 40-55	● 40-55	● 55-75	● 55-75	● 12-18	● 16-20		
● 25-30				● 6-10	● 6-10	● 10-14	● 10-14	● 35-45	● 35-45	● 50-60	● 50-60	● 6-10	● 8-14		
● 20-25															
● 40-55	○ 10-14	○ 10-14	○ 10-14	○ 15-20	○ 10-14	○ 15-20		○ 10-14	○ 10-14	○ 15-20			○ 10-14		
● 40-55	○ 8-12	○ 8-12	○ 8-12	○ 12-18	○ 8-12	○ 12-18		○ 8-12	○ 8-12	○ 12-18			○ 8-12		
● 25-30															
● 25-30															
● 40-55	● 20-25	● 20-25	● 20-25	● 20-25	● 20-25	● 30-35	● 30-35	● 60-80	● 60-80	● 80-100	● 80-100				
● 40-55	● 20-25	● 20-25	● 20-25	● 20-25	● 20-25	● 30-35	● 30-35	● 60-80	● 60-80	● 80-100	● 80-100				
● 35-45	● 15-20	● 15-20	● 15-20	● 15-20	● 15-20	● 20-25	● 20-25	● 40-60	● 40-60	● 55-80	● 55-80				
● 35-45	● 15-20	● 15-20	● 15-20	● 15-20	● 15-20	● 20-25	● 20-25	● 40-60	● 40-60	● 55-80	● 55-80				
● 20-25															
● 110-130								● 120-160	● 120-160	● 160-200	● 160-200				
● 100-110								● 100-130	● 100-130	● 140-180	● 140-180				
● 80-100	● 15-20	● 15-20	● 15-20	● 15-20	● 15-20	● 20-25	● 20-25	● 70-90	● 70-90	● 100-120	● 100-120			● 15-20	● 20-25
○ 40-55								○ 60-80	○ 60-80	○ 80-100	○ 80-100				
● 55-65	● 25-30	● 25-30	● 25-30	● 25-30	● 25-30	● 35-40	● 35-40	● 100-120	● 100-120	● 140-160	● 140-160				
● 45-55								● 80-100	● 80-100	● 110-140	● 110-140				
○ 25-30															
● 100-110															
○ 150-200	○ 10-15	○ 10-15	○ 10-15	● 25-30	● 25-30	● 35-40	● 35-40	○ 50-70	○ 50-70	○ 50-70	○ 50-70			● 25-30	● 35-40
● 70-100															
● 20-30															
● 25-30				● 10-12	● 10-12	● 12-16	● 12-16	● 20-30	● 20-30	● 25-35	● 25-35				
○ 25-25															
○ 15-20															
● 15-20															
● 10-15															
○ 4-6															

● Optima / Optimun ○ Alternativo / Alternative

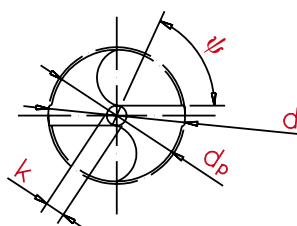
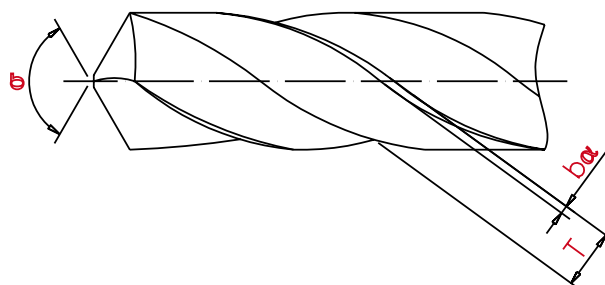
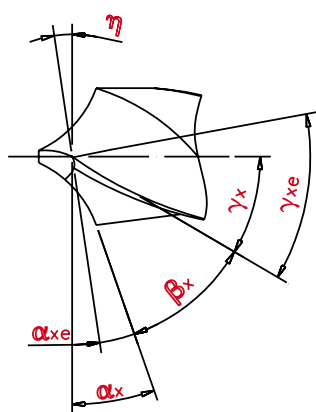
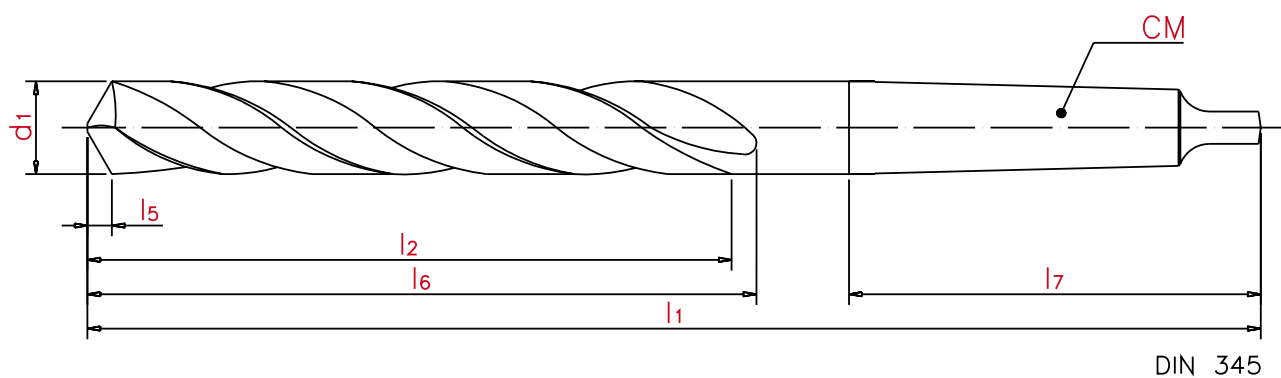
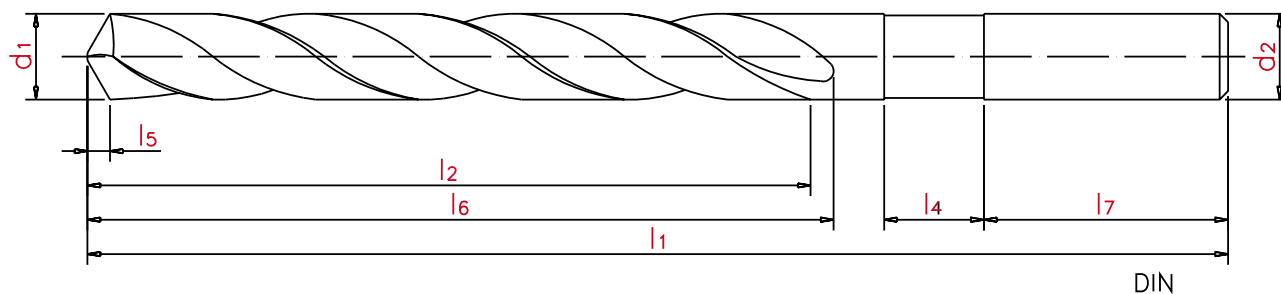



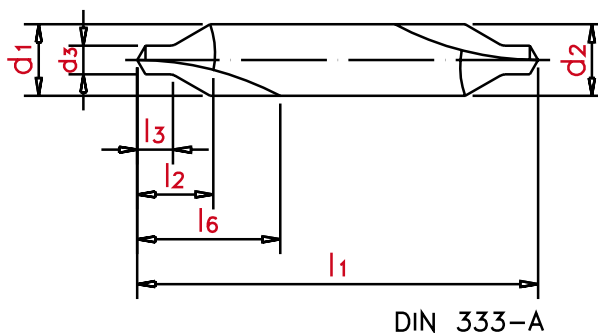
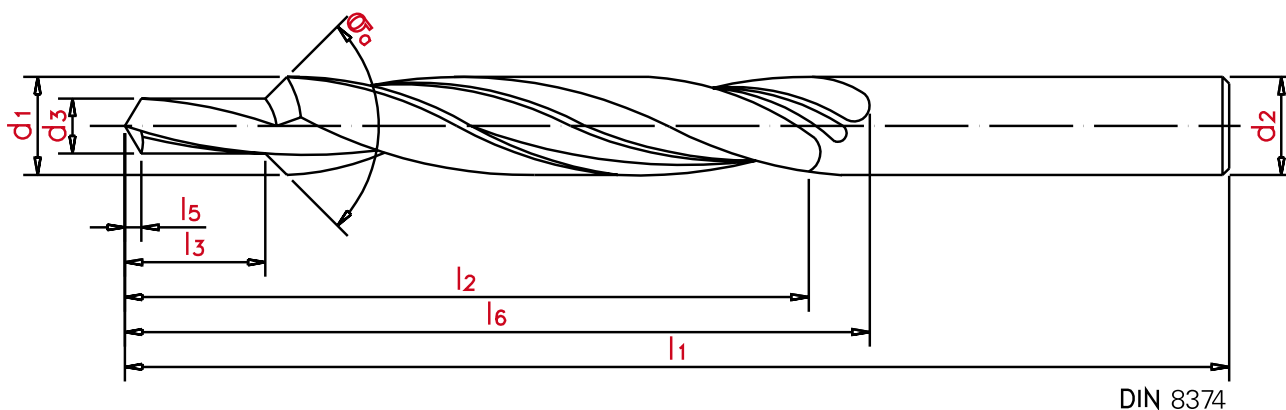

<b>l1</b>	Longitud total / Longueur totale / Total length
<b>l2</b>	Longitud de corte / Longueur de coupe / Length of cut
<b>l3</b>	Longitud de corte del diámetro menor / Longueur de coupe du plus petit diamètre / Length of cut of the smaller diameter
<b>l7</b>	Longitud del mango-del cono / Longueur de la queue du cône / Length of cone shank
<b>l5</b>	Longitud de punta / Longueur de pointe / Length of tip
<b>l6</b>	Longitud de ranura / Longueur de rainure / Length of groove
<b>l4</b>	Diámetro de broca / Diamètre de foret / Drill-bit diameter
<b>d1</b>	Longitud de sangrado / Longueur d'indentation / Bled length
<b>d3</b>	Diámetro inicial / Diamètre initial / Initial diameter
<b>d2</b>	Diámetro de mango / Diamètre de queue / Shank diameter
<b>CM</b>	Tamaño del cono morse / Taille du cône morse / Morse taper size
<b>dp</b>	Diámetro posterior / Diamètre postérieur / Rear diameter
<b>b<math>\alpha</math></b>	Ancho de fase / Largeur de phase / Phase width
<b>T</b>	Ancho de alma / Largeur d'âme / Core width
<b>k</b>	Espesor del núcleo / Épaisseur du noyau / Thickness of nucleus
$\sigma$	Ángulo de la punta / Angle de la pointe / Tip angle
<b><math>\sigma\alpha</math></b>	Ángulo de avellanado / Angle de chanfreinage / Countersink angle
$\psi$	Ángulo de corte transversal / Angle de coupe transversale / Transversal cut angle
<b><math>\gamma_{xe}</math></b>	Ángulo de corte lateral efectivo / Angle de coupe latérale effectif / Effective lateral cut angle
<b><math>\gamma_x</math></b>	Ángulo de corte lateral / Angle de coupe latérale / Lateral cut angle
<b><math>\alpha_{xe}</math></b>	Ángulo de incidencia lateral efectivo / Angle d'incidence latérale effectif / Effective lateral angle of incidence
<b><math>\alpha_x</math></b>	Ángulo de incidencia lateral / Angle d'incidence latérale / Lateral angle of incidence
<b><math>\beta_x</math></b>	Ángulo ortogonal de la herramienta / Angle orthogonal de l'outil / Orthogonal angle of the tool
<b><math>\eta</math></b>	Ángulo del sentido efectivo del corte / Angle du sens effectif de la coupe / Effective direction of cut angle

**1175**

**HM-MD DIN 6537 S**

**3XD**



DIN 6535 HA

TIALN

P				M		K			N				S		H		
<800	<1.000	<1.200	<1.400	<950	<1.200	<500	<800	<1.400	Al	Cu	Mg/Zn	Plastic	Ni	Ti	50 HRC	55 HRC	60 HRC
●	●	●	●	●	●	●	●	●					○	●	○	○	
40-110	35-75	30-50	25-40	35-75		60-100	70-110	40-60					20-25	20-75	25-35	15-25	

Vc (m/min). ● Optima / Optimun ○ Alternativo / Alternative

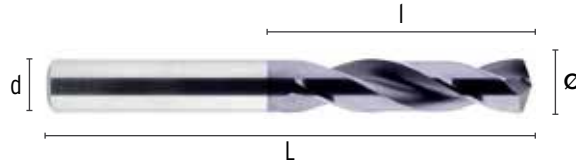

ø mm	d mm	€	L mm	l mm		ø mm	d mm	€	L mm	l mm	
3,00	6,00	36,04	20,00	62,00	1	8,80	10,00	65,13	47,00	89,00	1
3,10	6,00	36,04	20,00	62,00	1	8,90	10,00	65,13	47,00	89,00	1
3,20	6,00	36,04	20,00	62,00	1	9,00	10,00	65,13	47,00	89,00	1
3,30	6,00	36,04	20,00	62,00	1	9,10	10,00	65,13	47,00	89,00	1
3,40	6,00	36,04	20,00	62,00	1	9,20	10,00	65,13	47,00	89,00	1
3,50	6,00	36,04	20,00	62,00	1	9,30	10,00	65,13	47,00	89,00	1
3,60	6,00	36,04	20,00	62,00	1	9,40	10,00	65,13	47,00	89,00	1
3,70	6,00	36,04	20,00	62,00	1	9,50	10,00	65,13	47,00	89,00	1
3,80	6,00	36,04	24,00	66,00	1	9,60	10,00	65,13	47,00	89,00	1
3,90	6,00	36,04	24,00	66,00	1	9,70	10,00	65,13	47,00	89,00	1
4,00	6,00	36,04	24,00	66,00	1	9,80	10,00	65,13	47,00	89,00	1
4,10	6,00	36,04	24,00	66,00	1	9,90	10,00	65,13	47,00	89,00	1
4,20	6,00	36,04	24,00	66,00	1	10,00	10,00	65,13	47,00	89,00	1
4,30	6,00	36,04	24,00	66,00	1	10,10	12,00	98,25	55,00	102,00	1
4,40	6,00	36,04	24,00	66,00	1	10,20	12,00	98,25	55,00	102,00	1
4,50	6,00	36,04	24,00	66,00	1	10,30	12,00	98,25	55,00	102,00	1
4,60	6,00	36,04	24,00	66,00	1	10,40	12,00	98,25	55,00	102,00	1
4,70	6,00	36,04	24,00	66,00	1	10,50	12,00	98,25	55,00	102,00	1
4,80	6,00	36,04	28,00	66,00	1	10,60	12,00	98,25	55,00	102,00	1
4,90	6,00	36,04	28,00	66,00	1	10,70	12,00	98,25	55,00	102,00	1
5,00	6,00	36,04	28,00	66,00	1	10,80	12,00	98,25	55,00	102,00	1
5,10	6,00	36,04	28,00	66,00	1	10,90	12,00	98,25	55,00	102,00	1
5,20	6,00	36,04	28,00	66,00	1	11,00	12,00	98,25	55,00	102,00	1
5,30	6,00	36,04	28,00	66,00	1	11,20	12,00	98,25	55,00	102,00	1
5,40	6,00	36,04	28,00	66,00	1	11,30	12,00	98,25	55,00	102,00	1
5,50	6,00	36,04	28,00	66,00	1	11,50	12,00	98,25	55,00	102,00	1
5,60	6,00	36,04	28,00	66,00	1	11,60	12,00	98,25	55,00	102,00	1
5,70	6,00	36,04	28,00	66,00	1	11,80	12,00	98,25	55,00	102,00	1
5,80	6,00	36,04	28,00	66,00	1	12,00	12,00	98,25	55,00	102,00	1
5,90	6,00	36,04	28,00	66,00	1	12,20	14,00	130,18	60,00	107,00	1
6,00	6,00	36,04	28,00	66,00	1	12,30	14,00	130,18	60,00	107,00	1
6,10	8,00	48,90	34,00	79,00	1	12,50	14,00	130,18	60,00	107,00	1
6,20	8,00	48,90	34,00	79,00	1	12,80	14,00	130,18	60,00	107,00	1
6,30	8,00	48,90	34,00	79,00	1	13,00	14,00	130,18	60,00	107,00	1
6,40	8,00	48,90	34,00	79,00	1	13,30	14,00	130,18	60,00	107,00	1
6,50	8,00	48,90	34,00	79,00	1	13,50	14,00	130,18	60,00	107,00	1
6,60	8,00	48,90	34,00	79,00	1	13,80	14,00	130,18	60,00	107,00	1
6,70	8,00	48,90	34,00	79,00	1	14,00	14,00	130,18	60,00	107,00	1
6,80	8,00	48,90	34,00	79,00	1	14,50	16,00	164,50	65,00	115,00	1
6,90	8,00	48,90	34,00	79,00	1	14,80	16,00	164,50	65,00	115,00	1
7,00	8,00	48,90	34,00	79,00	1	15,00	16,00	164,50	65,00	115,00	1
7,10	8,00	48,90	41,00	79,00	1	15,20	16,00	164,50	65,00	115,00	1
7,20	8,00	48,90	41,00	79,00	1	15,30	16,00	164,50	65,00	115,00	1
7,30	8,00	48,90	41,00	79,00	1	15,40	16,00	164,50	65,00	115,00	1
7,40	8,00	48,90	41,00	79,00	1	15,50	16,00	164,50	65,00	115,00	1
7,50	8,00	48,90	41,00	79,00	1	15,80	16,00	164,50	65,00	115,00	1
7,60	8,00	48,90	41,00	79,00	1	16,00	16,00	164,50	65,00	115,00	1
7,70	8,00	48,90	41,00	79,00	1	16,50	18,00	225,39	73,00	123,00	1
7,80	8,00	48,90	41,00	79,00	1	16,80	18,00	225,39	73,00	123,00	1
7,90	8,00	48,90	41,00	79,00	1	17,00	18,00	225,39	73,00	123,00	1
8,00	8,00	48,90	41,00	79,00	1	17,50	18,00	225,39	73,00	123,00	1
8,10	10,00	65,13	47,00	89,00	1	17,80	18,00	225,39	73,00	123,00	1
8,20	10,00	65,13	47,00	89,00	1	18,00	18,00	225,39	73,00	123,00	1
8,30	10,00	65,13	47,00	89,00	1	18,50	20,00	286,26	79,00	131,00	1
8,40	10,00	65,13	47,00	89,00	1	18,80	20,00	286,26	79,00	131,00	1
8,50	10,00	65,13	47,00	89,00	1	19,00	20,00	286,26	79,00	131,00	1
8,60	10,00	65,13	47,00	89,00	1	19,50	20,00	286,26	79,00	131,00	1
8,70	10,00	65,13	47,00	89,00	1	20,00	20,00	286,26	79,00	131,00	1

1176

**HM-MD DIN 6537 S**

3XD



DIN 6535 HA

TIALN

P				M		K			N				S		H		
<800	<1.000	<1.200	<1.400	<950	<1.200	<500	<800	<1.400	Al	Cu	Mg/Zn	Plastic	Ni	Ti	50 HRC	55 HRC	60 HRC
●	●	●	●	●	○	●	●	●					●	●			○
50-120	40-85	35-55	30-45	40-85	30-55	70-150	80-120	50-70					25-30	25-40	30-40	20-35	15-25

Vc (m/min). ● Optima / Optimun ○ Alternativo / Alternative

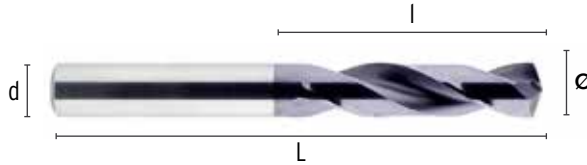

ø mm	d mm	€	L mm	l mm		ø mm	d mm	€	L mm	l mm	
3,00	6,00	57,51	20,00	62,00	1	8,80	10,00	93,75	47,00	89,00	1
3,10	6,00	57,51	20,00	62,00	1	8,90	10,00	93,75	47,00	89,00	1
3,20	6,00	57,51	20,00	62,00	1	9,00	10,00	93,75	47,00	89,00	1
3,30	6,00	57,51	20,00	62,00	1	9,10	10,00	93,75	47,00	89,00	1
3,40	6,00	57,51	20,00	62,00	1	9,20	10,00	93,75	47,00	89,00	1
3,50	6,00	57,51	20,00	62,00	1	9,30	10,00	93,75	47,00	89,00	1
3,60	6,00	57,51	20,00	62,00	1	9,40	10,00	93,75	47,00	89,00	1
3,70	6,00	57,51	20,00	62,00	1	9,50	10,00	93,75	47,00	89,00	1
3,80	6,00	57,51	24,00	66,00	1	9,60	10,00	93,75	47,00	89,00	1
3,90	6,00	57,51	24,00	66,00	1	9,70	10,00	93,75	47,00	89,00	1
4,00	6,00	62,15	24,00	66,00	1	9,80	10,00	93,75	47,00	89,00	1
4,10	6,00	62,15	24,00	66,00	1	9,90	10,00	93,75	47,00	89,00	1
4,20	6,00	62,15	24,00	66,00	1	10,00	10,00	93,75	47,00	89,00	1
4,30	6,00	62,15	24,00	66,00	1	10,10	12,00	132,50	55,00	102,00	1
4,40	6,00	62,15	24,00	66,00	1	10,20	12,00	132,50	55,00	102,00	1
4,50	6,00	62,15	24,00	66,00	1	10,30	12,00	132,50	55,00	102,00	1
4,60	6,00	62,15	24,00	66,00	1	10,40	12,00	132,50	55,00	102,00	1
4,70	6,00	62,15	24,00	66,00	1	10,50	12,00	132,50	55,00	102,00	1
4,80	6,00	62,15	28,00	66,00	1	10,60	12,00	132,50	55,00	102,00	1
4,90	6,00	62,15	28,00	66,00	1	10,70	12,00	132,50	55,00	102,00	1
5,00	6,00	62,15	28,00	66,00	1	10,80	12,00	132,50	55,00	102,00	1
5,10	6,00	62,15	28,00	66,00	1	10,90	12,00	132,50	55,00	102,00	1
5,20	6,00	62,15	28,00	66,00	1	11,00	12,00	132,50	55,00	102,00	1
5,30	6,00	62,15	28,00	66,00	1	11,20	12,00	132,50	55,00	102,00	1
5,40	6,00	62,15	28,00	66,00	1	11,30	12,00	132,50	55,00	102,00	1
5,50	6,00	62,15	28,00	66,00	1	11,50	12,00	132,50	55,00	102,00	1
5,60	6,00	62,15	28,00	66,00	1	11,60	12,00	132,50	55,00	102,00	1
5,70	6,00	62,15	28,00	66,00	1	11,80	12,00	132,50	55,00	102,00	1
5,80	6,00	62,15	28,00	66,00	1	12,00	12,00	132,50	55,00	102,00	1
5,90	6,00	62,15	28,00	66,00	1	12,20	14,00	168,07	60,00	107,00	1
6,00	6,00	62,15	28,00	66,00	1	12,30	14,00	168,07	60,00	107,00	1
6,10	8,00	74,73	34,00	79,00	1	12,50	14,00	168,07	60,00	107,00	1
6,20	8,00	74,73	34,00	79,00	1	12,80	14,00	168,07	60,00	107,00	1
6,30	8,00	74,73	34,00	79,00	1	13,00	14,00	168,07	60,00	107,00	1
6,40	8,00	74,73	34,00	79,00	1	13,30	14,00	168,07	60,00	107,00	1
6,50	8,00	74,73	34,00	79,00	1	13,50	14,00	168,07	60,00	107,00	1
6,60	8,00	74,73	34,00	79,00	1	13,80	14,00	168,07	60,00	107,00	1
6,70	8,00	74,73	34,00	79,00	1	14,00	14,00	168,07	60,00	107,00	1
6,80	8,00	74,73	34,00	79,00	1	14,50	16,00	209,02	65,00	115,00	1
6,90	8,00	74,73	34,00	79,00	1	14,80	16,00	209,02	65,00	115,00	1
7,00	8,00	74,73	34,00	79,00	1	15,00	16,00	209,02	65,00	115,00	1
7,10	8,00	74,73	41,00	79,00	1	15,20	16,00	209,02	65,00	115,00	1
7,20	8,00	74,73	41,00	79,00	1	15,30	16,00	209,02	65,00	115,00	1
7,30	8,00	74,73	41,00	79,00	1	15,40	16,00	209,02	65,00	115,00	1
7,40	8,00	74,73	41,00	79,00	1	15,50	16,00	209,02	65,00	115,00	1
7,50	8,00	74,73	41,00	79,00	1	15,80	16,00	209,02	65,00	115,00	1
7,60	8,00	74,73	41,00	79,00	1	16,00	16,00	209,02	65,00	115,00	1
7,70	8,00	74,73	41,00	79,00	1	16,50	18,00	333,43	73,00	123,00	1
7,80	8,00	74,73	41,00	79,00	1	16,80	18,00	333,43	73,00	123,00	1
7,90	8,00	74,73	41,00	79,00	1	17,00	18,00	333,43	73,00	123,00	1
8,00	8,00	74,73	41,00	79,00	1	17,50	18,00	333,43	73,00	123,00	1
8,10	10,00	93,75	47,00	89,00	1	17,80	18,00	333,43	73,00	123,00	1
8,20	10,00	93,75	47,00	89,00	1	18,00	18,00	333,43	73,00	123,00	1
8,30	10,00	93,75	47,00	89,00	1	18,50	20,00	362,05	79,00	131,00	1
8,40	10,00	93,75	47,00	89,00	1	18,80	20,00	362,05	79,00	131,00	1
8,50	10,00	93,75	47,00	89,00	1	19,00	20,00	362,05	79,00	131,00	1
8,60	10,00	93,75	47,00	89,00	1	19,50	20,00	362,05	79,00	131,00	1
8,70	10,00	93,75	47,00	89,00	1	20,00	20,00	362,05	79,00	131,00	1

**P** Aceros Aciers Steels Stähle

**M** Aceros Inox Aciers Inox Stainless Steels Edelstahl

**K** Fundición Fonte Cast Iron Gusseisen

**N** Metales no ferrosos Métal non Ferraux Non Ferrous metals NE-Metalle

**S** Titanio y Superalloys Titanium et Superalloys Titanium and Superalloys Titan und Superlegierungen

**H** Materiales Duros Matériels Durs Hard materials Hartmaterialien



# BROCAS METAL DURO FORETS CARBURE / HARD METAL DRILL-BITS / HARTMETALL-BOHRER

1177

HM-MD DIN 6537 L

5XD



P				M		K			N				S		H		
<800	<1.000	<1.200	<1.400	<950	<1.200	<500	<800	<1.400	Al	Cu	Mg/Zn	Plastic	Ni	Ti	50 HRC	55 HRC	60 HRC
●	●	●	●	●	○	●	●	●					●	●	●	●	○
50-120	40-85	35-55	30-45	40-85	30-55	70-150	80-120	50-70					25-30	25-40	30-40	20-35	15-25

Vc (m/min). ● Optima / Optimun ○ Alternativo / Alternative

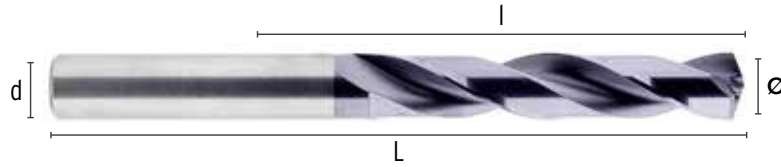

ø mm	d mm	€	L mm	l mm		ø mm	d mm	€	L mm	l mm	
3,00	6,00	66,19	28,00	66,00	1	8,80	10,00	98,64	61,00	103,00	1
3,10	6,00	66,19	28,00	66,00	1	8,90	10,00	98,64	61,00	103,00	1
3,20	6,00	66,19	28,00	66,00	1	9,00	10,00	98,64	61,00	103,00	1
3,30	6,00	66,19	28,00	66,00	1	9,10	10,00	98,64	61,00	103,00	1
3,40	6,00	66,19	28,00	66,00	1	9,20	10,00	98,64	61,00	103,00	1
3,50	6,00	66,19	28,00	66,00	1	9,30	10,00	98,64	61,00	103,00	1
3,60	6,00	66,19	28,00	66,00	1	9,40	10,00	98,64	61,00	103,00	1
3,70	6,00	66,19	28,00	66,00	1	9,50	10,00	98,64	61,00	103,00	1
3,80	6,00	66,19	36,00	74,00	1	9,60	10,00	98,64	61,00	103,00	1
3,90	6,00	66,19	36,00	74,00	1	9,70	10,00	98,64	61,00	103,00	1
4,00	6,00	70,36	36,00	74,00	1	9,80	10,00	98,64	61,00	103,00	1
4,10	6,00	70,36	36,00	74,00	1	9,90	10,00	98,64	61,00	103,00	1
4,20	6,00	70,36	36,00	74,00	1	10,00	10,00	98,64	61,00	103,00	1
4,30	6,00	70,36	36,00	74,00	1	10,10	12,00	139,72	71,00	118,00	1
4,40	6,00	70,36	36,00	74,00	1	10,20	12,00	139,72	71,00	118,00	1
4,50	6,00	70,36	36,00	74,00	1	10,30	12,00	139,72	71,00	118,00	1
4,60	6,00	70,36	36,00	74,00	1	10,40	12,00	139,72	71,00	118,00	1
4,70	6,00	70,36	36,00	74,00	1	10,50	12,00	139,72	71,00	118,00	1
4,80	6,00	70,36	44,00	82,00	1	10,60	12,00	139,72	71,00	118,00	1
4,90	6,00	70,36	44,00	82,00	1	10,70	12,00	139,72	71,00	118,00	1
5,00	6,00	70,36	44,00	82,00	1	10,80	12,00	139,72	71,00	118,00	1
5,10	6,00	70,36	44,00	82,00	1	10,90	12,00	139,72	71,00	118,00	1
5,20	6,00	70,36	44,00	82,00	1	11,00	12,00	139,72	71,00	118,00	1
5,30	6,00	70,36	44,00	82,00	1	11,20	12,00	139,72	71,00	118,00	1
5,40	6,00	70,36	44,00	82,00	1	11,30	12,00	139,72	71,00	118,00	1
5,50	6,00	70,36	44,00	82,00	1	11,50	12,00	139,72	71,00	118,00	1
5,60	6,00	70,36	44,00	82,00	1	11,60	12,00	139,72	71,00	118,00	1
5,70	6,00	70,36	44,00	82,00	1	11,80	12,00	139,72	71,00	118,00	1
5,80	6,00	70,36	44,00	82,00	1	12,00	12,00	139,72	71,00	118,00	1
5,90	6,00	70,36	44,00	82,00	1	12,20	14,00	186,70	77,00	124,00	1
6,00	6,00	70,36	44,00	82,00	1	12,30	14,00	186,70	77,00	124,00	1
6,10	8,00	78,64	53,00	91,00	1	12,50	14,00	186,70	77,00	124,00	1
6,20	8,00	78,64	53,00	91,00	1	12,80	14,00	186,70	77,00	124,00	1
6,30	8,00	78,64	53,00	91,00	1	13,00	14,00	186,70	77,00	124,00	1
6,40	8,00	78,64	53,00	91,00	1	13,30	14,00	186,70	77,00	124,00	1
6,50	8,00	78,64	53,00	91,00	1	13,50	14,00	186,70	77,00	124,00	1
6,60	8,00	78,64	53,00	91,00	1	13,80	14,00	186,70	77,00	124,00	1
6,70	8,00	78,64	53,00	91,00	1	14,00	14,00	186,70	77,00	124,00	1
6,80	8,00	78,64	53,00	91,00	1	14,50	16,00	232,20	83,00	133,00	1
6,90	8,00	78,64	53,00	91,00	1	14,80	16,00	232,20	83,00	133,00	1
7,00	8,00	78,64	53,00	91,00	1	15,00	16,00	232,20	83,00	133,00	1
7,10	8,00	78,64	53,00	91,00	1	15,20	16,00	232,20	83,00	133,00	1
7,20	8,00	78,64	53,00	91,00	1	15,30	16,00	232,20	83,00	133,00	1
7,30	8,00	78,64	53,00	91,00	1	15,40	16,00	232,20	83,00	133,00	1
7,40	8,00	78,64	53,00	91,00	1	15,50	16,00	232,20	83,00	133,00	1
7,50	8,00	78,64	53,00	91,00	1	15,80	16,00	232,20	83,00	133,00	1
7,60	8,00	78,64	53,00	91,00	1	16,00	16,00	232,20	83,00	133,00	1
7,70	8,00	78,64	53,00	91,00	1	16,50	18,00	370,27	93,00	143,00	1
7,80	8,00	78,64	53,00	91,00	1	16,80	18,00	370,27	93,00	143,00	1
7,90	8,00	78,64	53,00	91,00	1	17,00	18,00	370,27	93,00	143,00	1
8,00	8,00	78,64	53,00	91,00	1	17,50	18,00	370,27	93,00	143,00	1
8,10	10,00	98,64	61,00	103,00	1	17,80	18,00	370,27	93,00	143,00	1
8,20	10,00	98,64	61,00	103,00	1	18,00	18,00	370,27	93,00	143,00	1
8,30	10,00	98,64	61,00	103,00	1	18,50	20,00	402,67	101,00	153,00	1
8,40	10,00	98,64	61,00	103,00	1	18,80	20,00	402,67	101,00	153,00	1
8,50	10,00	98,64	61,00	103,00	1	19,00	20,00	402,67	101,00	153,00	1
8,60	10,00	98,64	61,00	103,00	1	19,50	20,00	402,67	101,00	153,00	1
8,70	10,00	98,64	61,00	103,00	1	20,00	20,00	402,67	101,00	153,00	1

**1178**

**HM-MD DIN 6537 EL**

**8XD**



P				M		K			N				S		H		
<800	<1.000	<1.200	<1.400	<950	<1.200	<500	<800	<1.400	Al	Cu	Mg/Zn	Plastic	Ni	Ti	50 HRC	55 HRC	60 HRC
●	●	●	●	●	○	●	●	●					●	●	●	●	○
50-120	40-85	35-55	30-45	40-85	30-55	70-150	80-120	50-70					25-30	25-40	30-40	20-35	15-25

Vc (m/min). ● Optima / Optimun ○ Alternativo / Alternative

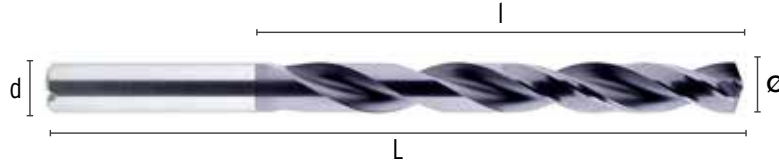

Ø mm	d mm	€	L mm	l mm	Icon	Ø mm	d mm	€	L mm	l mm	Icon
3,00	6,00	157,28	30,00	70,00	1	8,40*	10,00	220,22	87,00	131,00	1
3,10*	6,00	157,28	30,00	70,00	1	8,50	10,00	220,22	87,00	131,00	1
3,20*	6,00	157,28	30,00	70,00	1	8,60*	10,00	220,22	87,00	131,00	1
3,30	6,00	157,28	30,00	70,00	1	8,70*	10,00	220,22	87,00	131,00	1
3,40*	6,00	157,28	35,00	75,00	1	8,80*	10,00	220,22	87,00	131,00	1
3,50	6,00	157,28	35,00	75,00	1	8,90*	10,00	220,22	87,00	131,00	1
3,60*	6,00	157,28	35,00	75,00	1	9,00	10,00	220,22	87,00	131,00	1
3,70	6,00	157,28	35,00	75,00	1	9,10*	10,00	220,22	95,00	139,00	1
3,80*	6,00	157,28	37,00	75,00	1	9,20*	10,00	220,22	95,00	139,00	1
3,90*	6,00	157,28	37,00	75,00	1	9,30*	10,00	220,22	95,00	139,00	1
4,00	6,00	157,28	37,00	75,00	1	9,40*	10,00	220,22	95,00	139,00	1
4,10*	6,00	157,28	37,00	75,00	1	9,50	10,00	220,22	95,00	139,00	1
4,20	6,00	157,28	37,00	75,00	1	9,60*	10,00	220,22	95,00	139,00	1
4,30*	6,00	157,28	45,00	85,00	1	9,70*	10,00	220,22	95,00	139,00	1
4,40*	6,00	157,28	45,00	85,00	1	9,80*	10,00	220,22	95,00	139,00	1
4,50	6,00	157,28	45,00	85,00	1	9,90*	10,00	220,22	95,00	139,00	1
4,60*	6,00	157,28	45,00	85,00	1	10,00	10,00	220,22	95,00	139,00	1
4,70*	6,00	157,28	45,00	85,00	1	10,10*	12,00	300,78	106,00	155,00	1
4,80*	6,00	157,28	50,00	90,00	1	10,20	12,00	300,78	106,00	155,00	1
4,90*	6,00	157,28	50,00	90,00	1	10,30*	12,00	300,78	106,00	155,00	1
5,00	6,00	157,28	50,00	90,00	1	10,40*	12,00	300,78	106,00	155,00	1
5,10*	6,00	157,28	50,00	90,00	1	10,50	12,00	300,78	106,00	155,00	1
5,20*	6,00	157,28	50,00	90,00	1	10,60*	12,00	300,78	106,00	155,00	1
5,30*	6,00	157,28	50,00	90,00	1	10,70*	12,00	300,78	106,00	155,00	1
5,40*	6,00	157,28	57,00	97,00	1	10,80*	12,00	300,78	106,00	155,00	1
5,50	6,00	157,28	57,00	97,00	1	10,90*	12,00	300,78	106,00	155,00	1
5,60*	6,00	157,28	57,00	97,00	1	11,00	12,00	300,78	106,00	155,00	1
5,70*	6,00	157,28	57,00	97,00	1	11,20*	12,00	300,78	114,00	163,00	1
6,00	6,00	157,28	57,00	97,00	1	11,30*	12,00	300,78	114,00	163,00	1
6,10*	8,00	182,79	66,00	106,00	1	11,40*	12,00	300,78	114,00	163,00	1
6,20*	8,00	182,79	66,00	106,00	1	11,50*	12,00	300,78	114,00	163,00	1
6,30*	8,00	182,79	66,00	106,00	1	11,60*	12,00	300,78	114,00	163,00	1
6,40*	8,00	182,79	66,00	106,00	1	11,80*	12,00	300,78	114,00	163,00	1
6,50	8,00	182,79	66,00	106,00	1	12,00	12,00	300,78	114,00	163,00	1
6,60*	8,00	182,79	66,00	106,00	1	12,20*	14,00	428,18	133,00	182,00	1
6,70*	8,00	182,79	66,00	106,00	1	12,30*	14,00	428,18	133,00	182,00	1
6,80	8,00	182,79	66,00	106,00	1	12,50*	14,00	428,18	133,00	182,00	1
6,90*	8,00	182,79	76,00	116,00	1	13,00	14,00	428,18	133,00	182,00	1
7,00	8,00	182,79	76,00	116,00	1	13,50*	14,00	428,18	133,00	182,00	1
7,10*	8,00	182,79	76,00	116,00	1	14,00	14,00	428,18	133,00	182,00	1
7,20*	8,00	182,79	76,00	116,00	1	14,50*	16,00	533,71	152,00	204,00	1
7,30*	8,00	182,79	76,00	116,00	1	15,00	16,00	533,71	152,00	204,00	1
7,40*	8,00	182,79	76,00	116,00	1	15,50*	16,00	533,71	152,00	204,00	1
7,50	8,00	182,79	76,00	116,00	1	16,00	16,00	533,71	152,00	204,00	1
7,60*	8,00	182,79	76,00	116,00	1	16,50*	18,00	596,42	171,00	223,00	1
7,70*	8,00	182,79	76,00	116,00	1	17,00*	18,00	596,42	171,00	223,00	1
7,80*	8,00	182,79	76,00	116,00	1	17,50*	18,00	666,49	171,00	223,00	1
7,90*	8,00	182,79	76,00	116,00	1	18,00*	18,00	666,49	171,00	223,00	1
8,00	8,00	182,79	76,00	116,00	1	18,50*	20,00	943,93	190,00	244,00	1
8,10*	10,00	220,22	87,00	131,00	1	19,00*	20,00	943,93	190,00	244,00	1
8,20*	10,00	220,22	87,00	131,00	1	19,50*	20,00	943,93	190,00	244,00	1
8,30*	10,00	220,22	87,00	131,00	1	20,00*	20,00	943,93	190,00	244,00	1

\* Bajo demanda / Sur demande / Upon request / Auf nachfrage

**1184** **HM-MD**

**12XD**

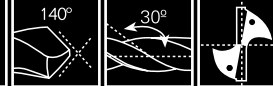

DIN 6535 HA

**TIALN**

P				M		K			N				S		H		
<800	<1.000	<1.200	<1.400	<950	<1.200	<500	<800	<1.400	Al	Cu	Mg/Zn	Plastic	Ni	Ti	50 HRC	55 HRC	60 HRC
●	●	●	●	●	●	●	●	●					●				
40-90	35-55	30-50	25-40	35-55		60-120	60-90	30-50					15-25				

Vc (m/min). ● Optima / Optimun ○ Alternativo / Alternative

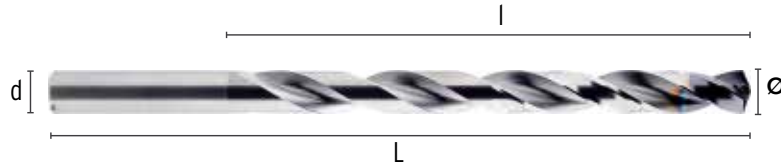

∅ mm	d mm	€	L mm	l mm	
3,00	6	211,27	90	50	1
3,30	6	211,27	90	50	1
3,50	6	211,27	90	50	1
3,70	6	211,27	90	50	1
4,00	6	211,27	102	64	1
4,20	6	211,27	102	64	1
4,50	6	211,27	102	64	1
4,70	6	211,27	102	64	1
5,00	6	211,27	116	78	1
5,50	6	211,27	116	78	1
6,00	6	211,27	116	78	1
6,50	8	260,43	146	108	1
6,80	8	260,43	146	108	1
7,00	8	260,43	146	108	1

∅ mm	d mm	€	L mm	l mm	
7,50	8	260,43	146	108	1
8,00	8	260,43	146	108	1
8,50	10	328,34	162	120	1
9,00	10	328,34	162	120	1
9,50	10	328,34	162	120	1
10,00	10	328,34	162	120	1
10,20	12	435,66	204	156	1
10,50	12	435,66	204	156	1
11,00	12	435,66	204	156	1
12,00	12	435,66	204	156	1
13,00	14	539,74	230	182	1
14,00	14	539,74	230	182	1
15,00	16	763,79	260	208	1
16,00	16	763,79	260	208	1

**1182** **HM-MD**

**1XD**

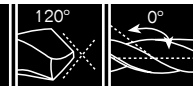

**TIN**

P				M		K			N				S		H		
<800	<1.000	<1.200	<1.400	<950	<1.200	<500	<800	<1.400	Al	Cu	Mg/Zn	Plastic	Ni	Ti	50 HRC	55 HRC	60 HRC
															●	●	●
															25-30	15-25	10-15

Vc (m/min). ● Optima / Optimun ○ Alternativo / Alternative

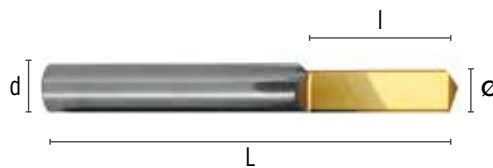

**"Sacar Machos rotos"**  
**"Enlever Taraud cassés"**  
**"Remove Broken Taps"**

∅ mm	M	€	L mm	l mm	d mm
2,5	M3	87,32	38	10	3
3,3	M4	120,11	46	14	4
4,2	M5	135,18	50	19	5
5	M6	150,12	50	23	6

∅ mm	M	€	L mm	l mm	d mm
6,8	M8	165,19	60	23	8
8,5	M10	210,18	80	25	10
10,2	M12	313,08	80	35	12

**1120**

**HM-MD DIN 6539 N**

**2XD**



P				M		K			N				S		H		
<800	<1.000	<1.200	<1.400	<950	<1.200	<500	<800	<1.400	Al	Cu	Mg/Zn	Plastic	Ni	Ti	50 HRC	55 HRC	60 HRC
●	●	●	●	●		●	●		●	●	●	●	○	○			
30-70	25-50	20-40	15-25	20-25		50-70	40-50		60-140	25-70	30-60	40-70	10-15	10-25			

Vc (m/min). ● Optima / Optimun ○ Alternativo / Alternative



Ø mm	€	L mm	l mm		Ø mm	€	L mm	l mm	
2,00	7,29	38	12	1	6,40	29,10	70	31	1
2,10	7,95	38	12	1	6,50	29,10	70	31	1
2,20	7,95	40	13	1	6,60	35,21	70	31	1
2,30	7,95	40	13	1	6,70	35,21	70	31	1
2,40	7,95	43	14	1	6,80	35,21	74	34	1
2,50	7,95	43	14	1	6,90	35,21	74	34	1
2,60	7,95	43	14	1	7,00	34,00	74	34	1
2,70	10,67	46	16	1	7,10	41,38	74	34	1
2,80	10,88	46	16	1	7,20	41,38	74	34	1
2,90	10,88	46	16	1	7,30	41,38	74	34	1
3,00	10,67	46	16	1	7,40	41,38	74	34	1
3,10	10,88	49	18	1	7,50	41,38	74	34	1
3,20	10,88	49	18	1	7,60	50,70	79	37	1
3,30	10,88	49	18	1	7,70	50,70	79	37	1
3,40	12,15	52	20	1	7,80	50,70	79	37	1
3,50	12,15	52	20	1	7,90	50,70	79	37	1
3,60	13,41	52	20	1	8,00	46,09	79	37	1
3,70	13,41	52	20	1	8,10	58,28	79	37	1
3,80	13,97	52	20	1	8,20	58,28	79	37	1
3,90	13,97	55	22	1	8,30	58,28	79	37	1
4,00	13,97	55	22	1	8,40	58,28	79	37	1
4,10	15,22	55	22	1	8,50	58,28	79	37	1
4,20	15,22	55	22	1	8,60	61,87	84	40	1
4,30	15,98	58	24	1	8,70	61,87	84	40	1
4,40	15,98	58	24	1	8,80	61,87	84	40	1
4,50	15,98	58	24	1	8,90	61,87	84	40	1
4,60	15,98	58	24	1	9,00	59,60	84	40	1
4,70	16,99	58	24	1	9,10	59,60	84	40	1
4,80	16,99	62	26	1	9,20	61,37	84	40	1
4,90	16,99	62	26	1	9,30	61,37	84	40	1
5,00	16,99	62	26	1	9,40	61,37	84	40	1
5,10	22,56	62	26	1	9,50	65,61	84	40	1
5,20	22,56	62	26	1	9,60	65,61	89	43	1
5,30	24,65	62	26	1	9,70	65,61	89	43	1
5,40	24,65	66	28	1	9,80	65,61	89	43	1
5,50	22,56	66	28	1	9,90	65,61	89	43	1
5,60	26,05	66	28	1	10,00	82,76	89	43	1
5,70	26,05	66	28	1	10,20	84,39	89	43	1
5,80	23,67	66	28	1	10,50	99,71	89	43	1
5,90	26,05	66	28	1	11,00	106,69	95	47	1
6,00	23,67	66	28	1	11,50	113,69	95	47	1
6,10	29,10	70	31	1	12,00	113,69	102	51	1
6,20	29,10	70	31	1	13,00	170,34	102	51	1
6,30	29,10	70	31	1					



**1109** **HM-MD DIN 338 N**

**4XD**

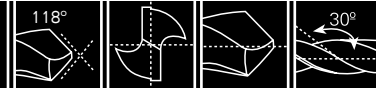

P				M		K			N				S		H		
<800	<1.000	<1.200	<1.400	<950	<1.200	<500	<800	<1.400	Al	Cu	Mg/Zn	Plastic	Ni	Ti	50 HRC	55 HRC	60 HRC
●	●	●	●	●		●	●		●	●	●	●	○	○			
30-70	25-50	20-40	15-25	20-25		50-70	40-50		60-140	25-70	30-60	40-70	10-15	10-25			

Vc (m/min). ● Optima / Optimun ○ Alternativo / Alternative

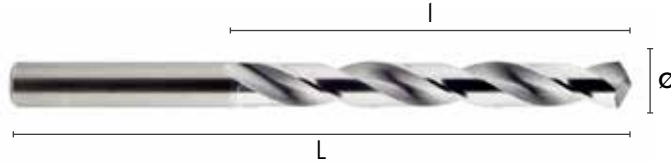

Ø mm	€	L mm	l mm	Icon	Ø mm	€	L mm	l mm	Icon
2,00	9,82	49	24	1	4,60	28,74	80	47	1
2,10	11,59	49	24	1	4,70	28,74	80	47	1
2,20	12,19	53	27	1	4,80	28,74	86	52	1
2,30	12,19	53	27	1	4,90	28,74	86	52	1
2,40	12,19	57	30	1	5,00	28,74	86	52	1
2,50	12,19	57	30	1	5,10	35,26	86	52	1
2,60	14,47	57	30	1	5,20	35,26	86	52	1
2,70	14,87	61	33	1	5,30	35,26	86	52	1
2,80	14,87	61	33	1	5,40	35,26	93	57	1
2,90	14,87	61	33	1	5,50	35,26	93	57	1
3,00	14,87	61	33	1	5,60	37,90	93	57	1
3,10	15,18	65	36	1	5,70	37,90	93	57	1
3,20	15,78	65	36	1	5,80	37,90	93	57	1
3,30	15,88	65	36	1	5,90	37,90	93	57	1
3,40	17,71	70	39	1	6,00	37,90	93	57	1
3,50	17,10	70	39	1	6,10	47,70	101	63	1
3,60	18,37	70	39	1	6,20	47,70	101	63	1
3,70	18,37	70	39	1	6,30	47,70	101	63	1
3,80	18,56	75	43	1	6,40	47,70	101	63	1
3,90	19,28	75	43	1	6,50	47,70	101	63	1
4,00	19,48	75	43	1	6,80	59,35	109	69	1
4,10	24,49	75	43	1	7,00	59,35	109	69	1
4,20	24,49	75	43	1	8,00	81,86	117	75	1
4,30	24,49	80	47	1	8,50	93,95	117	75	1
4,40	24,49	80	47	1	10,00	151,87	113	87	1
4,50	24,43	80	47	1	10,20	151,87	113	87	1



# BROCAS CON MANGO CILÍNDRICO CORTAS FORETS À QUEUE CYLINDRIQUE COURTES / SHORT STRAIGHT SHANK DRILL-BITS / KURZER ZYLINDERSCHAFT-BOHRER

## 1101 HSS DIN 338 N



P				M		K			N				S		H		
<800	<1.000	<1.200	<1.400	<950	<1.200	<500	<800	<1.400	Al	Cu	Mg/Zn	Plastic	Ni	Ti	50 HRC	55 HRC	60 HRC
●						●	●		○	●		○					
15-35						25-30	12-16		50-60	30-60		20-25					



Vc (m/min). ● Optima / Optimun ○ Alternativo / Alternative



Ø mm	€	L mm	l mm	Icon	Ø mm	€	L mm	l mm	Icon
0,20	2,69	19	2,50	10	2,70	1,19	61	33	10
0,25	2,69	19	3	10	2,75	1,06	61	33	10
0,30	2,69	19	3	10	2,80	1,19	61	33	10
0,35	2,69	19	3	10	2,85	1,30	61	33	10
0,40	2,69	20	5	10	2,90	1,19	61	33	10
0,45	2,69	22	6	10	2,95	1,30	61	33	10
0,50	1,99	22	6	10	3,00	0,83	61	33	10
0,55	2,02	24	7	10	3,05	1,38	65	36	10
0,60	2,02	24	7	10	3,10	1,18	65	36	10
0,65	2,02	26	8	10	3,15	1,38	65	36	10
0,70	2,02	28	9	10	3,20	1,18	65	36	10
0,75	1,91	28	9	10	3,25	1,04	65	36	10
0,80	1,91	30	10	10	3,30	1,25	65	36	10
0,85	1,91	30	10	10	3,35	1,38	70	39	10
0,90	1,91	32	11	10	3,40	1,25	70	39	10
0,95	1,91	32	11	10	3,45	1,38	70	39	10
1,00	1,14	34	12	10	3,50	1,04	70	39	10
1,05	1,43	34	12	10	3,55	1,54	70	39	10
1,10	1,30	36	14	10	3,60	1,38	70	39	10
1,15	1,30	36	14	10	3,65	1,54	70	39	10
1,20	1,30	38	16	10	3,70	1,38	70	39	10
1,25	1,06	38	16	10	3,75	1,26	70	39	10
1,30	1,19	38	16	10	3,80	1,38	75	43	10
1,35	1,30	40	18	10	3,90	1,38	75	43	10
1,40	1,19	40	18	10	3,95	1,53	75	43	10
1,45	1,24	40	18	10	4,00	1,07	75	43	10
1,50	0,96	40	18	10	4,05	1,64	75	43	10
1,55	1,24	43	20	10	4,10	1,49	75	43	10
1,60	1,14	43	20	10	4,15	1,64	75	43	10
1,65	1,24	43	20	10	4,20	1,49	75	43	10
1,70	1,14	43	20	10	4,25	1,38	75	43	10
1,75	1,06	46	22	10	4,30	1,63	80	47	10
1,80	1,14	46	22	10	4,40	1,63	80	47	10
1,85	1,14	46	22	10	4,50	1,38	80	47	10
1,90	1,14	46	22	10	4,55	2,02	80	47	10
1,95	1,24	49	24	10	4,60	1,84	80	47	10
2,00	0,94	49	24	10	4,65	2,02	80	47	10
2,05	1,24	49	24	10	4,70	1,84	80	47	10
2,10	1,14	49	24	10	4,75	1,70	80	47	10
2,15	1,24	53	27	10	4,80	1,84	86	52	10
2,20	1,14	53	27	10	4,90	1,84	86	52	10
2,25	1,04	53	27	10	5,00	1,36	86	52	10
2,30	1,14	53	27	10	5,10	2,05	86	52	10
2,35	1,14	53	27	10	5,20	2,26	86	52	10
2,40	1,14	57	30	10	5,25	1,73	86	52	10
2,45	1,24	57	30	10	5,30	2,05	86	52	10
2,50	0,94	57	30	10	5,40	2,05	93	57	10
2,55	1,30	57	30	10	5,50	1,73	93	57	10
2,60	1,19	57	30	10	5,60	2,36	93	57	10
2,65	1,19	57	30	10	5,70	2,36	93	57	10

**BROCAS CON MANGO CILÍNDRICO CORTAS**  
**FORETS À QUEUE CYLINDRIQUE COURTES / SHORT STRAIGHT SHANK DRILL-BITS /**  
**KURZER ZYLINDERSCHAFT-BOHRER**

(continúa Ref.11010 / suite Réf.11010 / Ref.11010 cont'd)

Ø mm	€	L mm	l mm		Ø mm	€	L mm	l mm	
5,75	2,15	93	57	10	10,10	7,34	133	87	5
5,80	2,36	93	57	10	10,20	7,34	133	87	5
5,85	2,59	93	57	10	10,25	6,75	133	87	5
5,90	2,36	93	57	10	10,30	7,34	133	87	5
6,00	1,82	93	57	10	10,40	7,34	133	87	5
6,10	2,77	101	63	10	10,50	6,14	133	87	5
6,20	2,77	101	63	10	10,60	8,19	133	87	5
6,25	2,54	101	63	10	10,70	8,19	142	94	5
6,30	2,77	101	63	10	10,75	7,52	142	94	5
6,35	3,05	101	63	10	10,80	8,19	142	94	5
6,40	2,77	101	63	10	10,90	8,19	142	94	5
6,50	2,34	101	63	10	11,00	6,82	142	94	5
6,60	3,20	101	63	10	11,10	9,11	142	94	5
6,70	3,20	101	63	10	11,20	9,11	142	94	5
6,75	2,94	109	69	10	11,25	8,36	142	94	5
6,80	3,20	109	69	10	11,30	9,11	142	94	5
6,90	3,20	109	69	10	11,40	9,11	142	94	5
6,95	3,54	109	69	10	11,50	7,56	142	94	5
7,00	2,69	109	69	10	11,60	9,58	142	94	5
7,10	3,64	109	69	10	11,70	9,58	142	94	5
7,20	3,64	109	69	10	11,75	8,80	142	94	5
7,25	3,35	109	69	10	11,80	9,58	142	94	5
7,30	3,64	109	69	10	11,90	9,58	151	101	5
7,35	3,99	109	69	10	12,00	8,01	151	101	5
7,40	3,64	109	69	10	12,10	10,80	151	101	5
7,50	3,03	109	69	10	12,20	10,80	151	101	5
7,60	3,98	117	75	10	12,25	9,88	151	101	5
7,65	4,38	117	75	10	12,30	10,80	151	101	5
7,70	3,98	117	75	10	12,40	10,80	151	101	5
7,75	3,65	117	75	10	12,50	8,97	151	101	5
7,80	3,98	117	75	10	12,60	11,79	151	101	5
7,90	3,98	117	75	10	12,70	11,79	151	101	5
7,95	4,38	117	75	10	12,75	10,80	151	101	5
8,00	3,17	117	75	10	12,80	11,79	151	101	5
8,10	4,74	117	75	10	12,90	11,79	151	101	5
8,15	5,22	117	75	10	13,00	9,86	151	101	5
8,20	4,74	117	75	10	13,25	13,75	160	108	4
8,25	4,37	117	75	10	13,50	12,51	160	108	4
8,30	4,74	117	75	10	13,75	14,88	160	108	4
8,40	4,74	117	75	10	14,00	13,53	160	108	4
8,45	5,22	117	75	10	14,25	16,96	169	114	4
8,50	3,98	117	75	10	14,50	15,42	169	114	4
8,60	5,18	125	81	10	14,75	19,40	169	114	4
8,65	5,70	125	81	10	15,00	17,63	169	114	4
8,70	5,18	125	81	10	15,25	23,38	178	120	1
8,75	4,74	125	81	10	15,50	21,27	178	120	1
8,80	5,18	125	81	10	15,75	23,38	178	120	1
8,90	5,70	125	81	10	16,00	21,27	178	120	1
8,95	5,70	125	81	10	16,25	30,24	184	125	1
9,00	4,36	125	81	10	16,50	27,46	184	125	1
9,05	6,17	125	81	10	16,75	30,24	184	125	1
9,10	5,82	125	81	10	17,00	27,46	184	125	1
9,20	5,82	125	81	10	17,25	33,64	191	130	1
9,25	5,82	125	81	10	17,50	30,59	191	130	1
9,30	5,82	125	81	10	17,75	33,64	191	130	1
9,35	6,43	125	81	10	18,00	30,59	191	130	1
9,40	5,82	125	81	10	18,25	37,55	198	135	1
9,45	6,43	125	81	10	18,50	34,13	198	135	1
9,50	4,89	125	81	10	18,75	37,55	198	135	1
9,60	6,52	133	87	10	19,00	34,13	198	135	1
9,70	6,52	133	87	10	19,25	45,01	205	140	1
9,75	5,97	133	87	10	19,50	40,93	205	140	1
9,80	6,52	133	87	10	19,75	45,00	205	140	1
9,90	6,52	133	87	10	20,00	40,93	205	140	1
10,00	4,97	133	87	5					

# BROCAS CON MANGO CILÍNDRICO CORTAS FORETS À QUEUE CYLINDRIQUE COURTES / SHORT STRAIGHT SHANK DRILL-BITS / KURZER ZYLINDERSCHAFT-BOHRER

## 1101/1 HSS DIN 338 N Izquierda / A gauche / Left hand

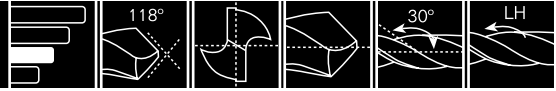

P				M		K			N				S		H		
<800	<1.000	<1.200	<1.400	<950	<1.200	<500	<800	<1.400	Al	Cu	Mg/Zn	Plastic	Ni	Ti	50 HRC	55 HRC	60 HRC
●						●	●		○	●		○					
15-35						25-30	12-16		50-60	30-60		20-25					

Vc (m/min). ● Optima / Optimun ○ Alternativo / Alternative

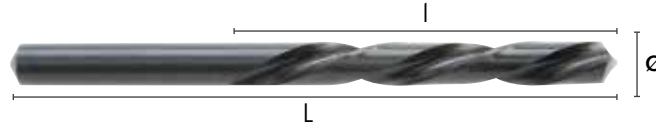

Ø mm	€	L mm	l mm	📦
2,00	4,57	49	24	10
2,25	5,05	53	27	10
2,50	4,57	57	30	10
2,75	5,22	61	33	10
3,00	4,07	61	33	10
3,25	5,09	65	36	10
3,50	5,09	70	39	10
3,75	6,28	70	39	10
4,00	5,25	75	43	10
4,50	6,68	80	47	10
5,00	6,64	86	52	10
5,25	8,45	86	52	10
5,50	8,45	93	57	10

Ø mm	€	L mm	l mm	📦
6,00	8,96	93	57	10
6,50	11,37	101	63	10
7,00	13,15	109	69	10
7,50	14,97	109	69	10
8,00	15,53	117	75	10
8,50	19,56	117	75	10
9,00	21,26	125	81	10
9,50	23,86	125	81	10
10,00	24,39	133	87	5
10,50	30,64	133	87	5
11,00	34,09	142	94	5
11,50	37,79	142	94	5
12,00	39,30	151	101	5

## 1104 HSS DIN 338 N MR



P				M		K			N				S		H		
<800	<1.000	<1.200	<1.400	<950	<1.200	<500	<800	<1.400	Al	Cu	Mg/Zn	Plastic	Ti	Ni	50 HRC	55 HRC	60 HRC
●						●	●		○	●		○					
15-35						25-30	12-16		50-60	30-60		20-25					

Vc (m/min). ● Optima / Optimun ○ Alternativo / Alternative

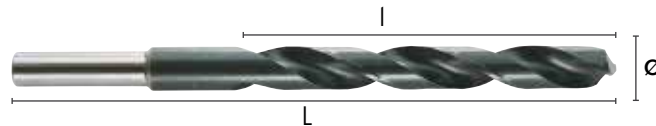

Ø mm	d mm	€	L mm	l mm	📦
10,00	8	8,47	133	87	1
10,50	8	9,73	133	87	1
11,00	8	9,73	142	94	1
11,50	8	10,88	142	94	1
12,00	8	10,88	151	101	1
12,50	8	12,00	151	101	1
13,00	10	13,23	151	101	1
13,25	10	16,86	160	108	1
13,50	10	16,86	160	108	1
13,75	10	18,33	160	108	1
14,00	10	16,86	160	108	1
14,25	10	21,14	169	114	1
14,40	10	20,83	169	114	1
14,50	10	20,75	169	114	1
14,75	10	29,75	169	114	1
15,00	10	20,75	169	114	1
15,25	10	27,51	178	120	1
15,50	10	24,57	178	120	1

Ø mm	d mm	€	L mm	l mm	📦
15,75	10	27,02	178	120	1
16,00	12	24,57	178	120	1
16,25	12	34,98	184	125	1
16,40	12	31,67	184	125	1
16,50	12	30,80	184	125	1
16,75	12	33,92	184	125	1
17,00	12	30,80	184	125	1
17,25	12	37,74	191	130	1
17,50	12	34,08	191	130	1
17,75	12	37,47	191	130	1
18,00	12	34,08	191	130	1
18,25	12	41,81	198	135	1
18,50	12	38,27	198	135	1
18,60	12	41,49	198	135	1
18,75	12	42,06	198	135	1
19,00	12	38,27	198	135	1
19,25	12	50,45	205	140	1
19,50	12	45,13	205	140	1



# BROCAS CON MANGO CILÍNDRICO CORTAS FORETS À QUEUE CYLINDRIQUE COURTES / SHORT STRAIGHT SHANK DRILL-BITS / KURZER ZYLINDERSCHAFT-BOHRER

Ø mm	d mm	€	L mm	l mm	📦
19,75	12	49,61	205	149	1
20,00	13	45,13	205	140	1
20,50	13	52,53	212	145	1
20,60	13	43,25	212	145	1
21,00	13	52,53	212	145	1
21,50	13	57,23	219	150	1
22,00	13	57,23	219	150	1
22,50	13	60,52	226	155	1
22,60	13	54,74	226	155	1
23,00	13	60,52	226	155	1
23,50	13	67,37	226	155	1
24,00	13	67,37	233	160	1

Ø mm	d mm	€	L mm	l mm	📦
24,50	13	68,32	233	160	1
25,00	13	68,32	233	160	1
25,50	13	88,71	240	165	1
26,00	13	88,71	240	165	1
26,50	13	95,77	240	165	1
27,00	13	95,77	247	170	1
27,50	13	97,21	247	170	1
28,00	13	97,21	247	170	1
28,50	13	120,83	254	175	1
29,00	13	120,83	254	175	1
29,50	13	126,08	254	175	1
30,00	13	126,08	254	175	1

## 1104/9 HSS ANSI



P				M		K			N				S		H		
<800	<1.000	<1.200	<1.400	<950	<1.200	<500	<800	<1.400	Al	Cu	Mg/Zn	Plastic	Ti	Ni	50 HRC	55 HRC	60 HRC
●						●	●		○	●							
15-35						25-30	12-16		50-60	30-60		20-25					

Vc (m/min). ● Optima / Optimun ○ Alternativo / Alternative



Ø mm	d mm	€	L mm	l mm	📦
17/32"	1/2"	16,86	152	76	1
9/16"	1/2"	16,86	152	76	1
19/32"	1/2"	20,75	152	76	1
5/8"	1/2"	24,57	152	76	1
21/32"	1/2"	30,80	152	76	1
11/16"	1/2"	34,08	152	76	1
23/32"	1/2"	34,08	152	76	1
3/4"	1/2"	38,27	152	76	1
25/32"	1/2"	45,13	152	76	1

Ø mm	d mm	€	L mm	l mm	📦
13/16"	1/2"	43,25	152	76	1
27/32"	1/2"	52,53	152	76	1
7/8"	1/2"	57,24	152	76	1
29/32"	1/2"	60,52	152	76	1
15/16"	1/2"	67,37	152	76	1
31/32"	1/2"	68,32	152	76	1
1"	1/2"	68,32	152	76	1
1-1/16"	1/2"	95,77	152	76	1
1-1/8"	1/2"	120,83	152	76	1

## 1501 HSS Hex.



P				M		K			N				S		H		
<800	<1.000	<1.200	<1.400	<950	<1.200	<500	<800	<1.400	Al	Cu	Mg/Zn	Plastic	Ti	Ni	50 HRC	55 HRC	60 HRC
●						●	●		○	●							
15-35						25-30	12-16		50-60	30-60		20-25					

Vc (m/min). ● Optima / Optimun ○ Alternativo / Alternative



Ø mm	L mm	l mm	€	📦
3,00	61	33	3,72	1
4,00	75	43	4,09	1
5,00	86	52	4,27	1
6,00	93	57	4,60	1

Ø mm	L mm	l mm	€	📦
7,00	109	69	4,74	1
8,00	117	75	5,00	1
9,00	125	81	5,07	1
10,00	133	87	6,38	1

# BROCAS CON MANGO CILÍNDRICO CORTAS FORETS À QUEUE CYLINDRIQUE COURTES / SHORT STRAIGHT SHANK DRILL-BITS / KURZER ZYLINDERSCHAFT-BOHRER

1158

HSS DIN 338 NSP



P				M		K			N				S		H		
<800	<1.000	<1.200	<1.400	<950	<1.200	<500	<800	<1.400	Al	Cu	Mg/Zn	Plastic	Ni	Ti	50 HRC	55 HRC	60 HRC
●						●	●		○	●		○					
15-35						25-30	12-16		50-60	30-60		20-25					

Vc (m/min). ● Optima / Optimun ○ Alternativo / Alternative





Ø mm	€	L mm	l mm	Icon	Ø mm	€	L mm	l mm	Icon
1,00	1,25	34	12	Icon	5,30	2,73	86	52	Icon
1,10	1,56	36	14	Icon	5,40	2,73	93	57	Icon
1,20	1,56	38	16	Icon	5,50	1,90	93	57	Icon
1,30	1,38	38	16	Icon	5,60	2,87	93	57	Icon
1,40	1,38	40	18	Icon	5,70	2,87	93	57	Icon
1,50	1,08	40	18	Icon	5,75	2,39	93	57	Icon
1,60	1,33	43	20	Icon	5,80	2,73	93	57	Icon
1,70	1,33	43	20	Icon	5,90	2,73	93	57	Icon
1,80	1,18	46	22	Icon	6,00	2,02	93	57	Icon
1,90	1,18	46	22	Icon	6,10	3,14	101	63	Icon
2,00	1,03	49	24	Icon	6,20	3,14	101	63	Icon
2,10	1,14	49	24	Icon	6,25	2,83	101	63	Icon
2,20	1,14	53	27	Icon	6,30	3,32	101	63	Icon
2,25	1,14	53	27	Icon	6,40	3,37	101	63	Icon
2,30	1,37	53	27	Icon	6,50	2,57	101	63	Icon
2,40	1,37	57	30	Icon	6,60	4,14	101	63	Icon
2,50	1,03	57	30	Icon	6,70	4,14	101	63	Icon
2,60	1,38	57	30	Icon	6,75	3,24	109	69	Icon
2,70	1,38	61	33	Icon	6,80	3,13	109	69	Icon
2,75	1,18	61	33	Icon	6,90	4,58	109	69	Icon
2,80	1,38	61	33	Icon	7,00	2,97	109	69	Icon
2,90	1,38	61	33	Icon	7,10	4,87	109	69	Icon
3,00	0,93	61	33	Icon	7,20	4,87	109	69	Icon
3,10	1,18	65	36	Icon	7,25	3,71	109	69	Icon
3,20	1,18	65	36	Icon	7,30	4,87	109	69	Icon
3,25	1,14	65	36	Icon	7,40	4,87	109	69	Icon
3,30	1,18	65	36	Icon	7,50	3,37	109	69	Icon
3,40	1,51	70	39	Icon	7,60	5,71	117	75	Icon
3,50	1,14	70	39	Icon	7,70	5,71	117	75	Icon
3,60	1,57	70	39	Icon	7,75	4,05	117	75	Icon
3,70	1,57	70	39	Icon	7,80	5,79	117	75	Icon
3,75	1,40	70	39	Icon	7,90	5,79	117	75	Icon
3,80	1,65	75	43	Icon	8,00	3,49	117	75	Icon
3,90	1,65	75	43	Icon	8,10	5,87	117	75	Icon
4,00	1,18	75	43	Icon	8,20	5,87	117	75	Icon
4,10	1,45	75	43	Icon	8,25	4,82	117	75	Icon
4,20	1,45	75	43	Icon	8,30	6,16	117	75	Icon
4,25	1,49	75	43	Icon	8,40	6,16	117	75	Icon
4,30	1,95	80	47	Icon	8,50	4,41	117	75	Icon
4,40	1,95	80	47	Icon	8,60	7,74	125	81	Icon
4,50	1,49	80	47	Icon	8,70	7,74	125	81	Icon
4,60	1,99	80	47	Icon	8,75	5,25	125	81	Icon
4,70	1,99	80	47	Icon	8,80	7,78	125	81	Icon
4,75	1,87	80	47	Icon	8,90	7,78	125	81	Icon
4,80	2,16	86	52	Icon	9,00	4,81	125	81	Icon
4,90	2,13	86	52	Icon	9,10	7,80	125	81	Icon
5,00	1,49	86	52	Icon	9,20	7,80	125	81	Icon
5,10	2,17	86	52	Icon	9,25	6,44	125	81	Icon
5,20	2,17	86	52	Icon	9,30	7,27	125	81	Icon
5,25	1,90	86	52	Icon	9,40	7,27	125	81	Icon



# BROCAS CON MANGO CILÍNDRICO CORTAS FORETS À QUEUE CYLINDRIQUE COURTES / SHORT STRAIGHT SHANK DRILL-BITS / KURZER ZYLINDERSCHAFT-BOHRER

(continúa Ref.1158 / suite Réf.1158 / Ref.1158 cont'd)

Ø mm	€	L mm	l mm	
9,50	5,38	125	81	10
9,60	9,31	133	87	10
9,70	9,31	133	87	10
9,75	6,59	133	87	10
9,80	9,17	133	87	10
9,90	9,17	133	87	10
10,00	5,48	133	87	5
10,50	6,77	133	87	5
11,00	7,54	142	94	5
11,50	8,36	142	94	5
12,00	8,85	151	101	5
12,50	9,92	151	101	5
13,00	10,85	151	101	5
13,50	13,74	151	101	4

Ø mm	€	L mm	l mm	
14,00	14,88	169	108	4
14,50	16,96	169	114	4
15,00	19,38	169	114	4
15,50	23,37	178	120	1
16,00	23,37	178	120	1
16,50	30,19	184	125	1
17,00	30,19	184	125	1
17,50	33,63	191	130	1
18,00	33,63	191	130	1
18,50	37,53	198	125	1
19,00	37,53	198	125	1
19,50	44,98	205	140	1
20,00	44,98	205	140	1

## 1158/9 HSS DIN 338 NSP



P				M		K			N				S		H		
<800	<1.000	<1.200	<1.400	<950	<1.200	<500	<800	<1.400	Al	Cu	Mg/Zn	Plastic	Ti	Ni	50 HRC	55 HRC	60 HRC
● 15-35						● 25-30	● 12-16		○ 50-60	● 30-60		○ 20-25					

Vc (m/min). ● Optima / Optimun ○ Alternativo / Alternative



Ø mm	€	L mm	l mm	
1/16"	1,08	43	20	10
5/64"	1,03	49	24	10
3/32"	1,03	57	30	10
7/64"	1,18	61	33	10
1/8"	0,93	65	36	10
9/64"	1,14	70	39	10
5/32"	1,18	75	43	10
11/64"	1,49	80	47	10
3/16"	1,49	86	52	10
13/64"	1,49	86	52	10
7/32"	1,90	93	57	10
15/64"	2,02	93	57	10
1/4"	2,57	101	63	10
17/64"	2,97	109	69	10
9/32"	2,97	109	69	10

Ø mm	€	L mm	l mm	
19/64"	3,37	117	75	10
5/16"	3,49	117	75	10
21/64"	4,41	117	75	10
11/32"	4,81	125	81	10
23/64"	4,81	125	81	10
3/8"	5,38	133	87	10
25/64"	5,48	133	87	10
13/32"	6,77	133	87	5
27/64"	7,11	142	94	5
7/16"	7,54	142	94	5
29/64"	8,36	142	94	5
15/32"	8,85	151	101	5
31/64"	9,92	151	101	5
1/2"	10,85	151	101	5

# BROCAS CON MANGO CILÍNDRICO CORTAS FORETS À QUEUE CYLINDRIQUE COURTES / SHORT STRAIGHT SHANK DRILL-BITS / KURZER ZYLINDERSCHAFT-BOHRER

**1108 HSS DIN 338 NSP**



P				M		K			N				S		H		
<800	<1.000	<1.200	<1.400	<950	<1.200	<500	<800	<1.400	Al	Cu	Mg/Zn	Plastic	Ni	Ti	50 HRC	55 HRC	60 HRC
●	●					●	●		○	●	○	○					
20-45	15-30					35-40	15-20		65-90	40-70	65-90	25-35					

Vc (m/min). ● Optima / Optimun ○ Alternativo / Alternative





Ø mm	€	L mm	l mm	📦	Ø mm	€	L mm	l mm	📦
1,00	2,54	34	12	10	5,30	3,64	86	52	10
1,10	2,27	36	14	10	5,40	3,64	93	57	10
1,20	2,27	38	16	10	5,50	3,64	93	57	10
1,30	2,27	38	16	10	5,60	4,02	93	57	10
1,40	2,27	40	18	10	5,70	4,02	93	57	10
1,50	1,97	40	18	10	5,75	4,02	93	57	10
1,60	2,27	43	20	10	5,80	4,02	93	57	10
1,70	2,27	43	20	10	5,90	4,02	93	57	10
1,80	2,27	46	22	10	6,00	4,02	93	57	10
1,90	2,27	46	22	10	6,10	4,94	101	63	10
2,00	1,97	49	24	10	6,20	4,94	101	63	10
2,10	2,27	49	24	10	6,25	4,94	101	63	10
2,20	2,27	53	27	10	6,30	4,94	101	63	10
2,25	2,27	53	27	10	6,40	4,94	101	63	10
2,30	2,27	53	27	10	6,50	4,94	101	63	10
2,40	2,27	57	30	10	6,60	5,71	101	63	10
2,50	1,97	57	30	10	6,70	5,71	101	63	10
2,60	2,27	57	30	10	6,75	5,73	109	69	10
2,70	2,27	61	33	10	6,80	6,60	109	69	10
2,75	1,97	61	33	10	6,90	6,60	109	69	10
2,80	2,27	61	33	10	7,00	6,60	109	69	10
2,90	2,27	61	33	10	7,10	6,60	109	69	10
3,00	2,15	61	33	10	7,20	6,60	109	69	10
3,10	2,53	65	36	10	7,25	7,16	109	69	10
3,20	2,53	65	36	10	7,30	7,16	109	69	10
3,25	2,19	65	36	10	7,40	7,16	109	69	10
3,30	2,53	65	36	10	7,50	7,16	109	69	10
3,40	2,53	70	39	10	7,60	7,47	117	75	10
3,50	2,39	70	39	10	7,70	7,47	117	75	10
3,60	2,80	70	39	10	7,75	7,47	117	75	10
3,70	2,80	70	39	10	7,80	7,54	117	75	10
3,75	2,47	70	39	10	7,90	7,54	117	75	10
3,80	2,80	75	43	10	8,00	7,54	117	75	10
3,90	2,80	75	43	10	8,10	8,71	117	75	10
4,00	2,69	75	43	10	8,20	8,71	117	75	10
4,10	3,37	75	43	10	8,25	8,71	117	75	10
4,20	3,37	75	43	10	8,30	8,71	117	75	10
4,25	2,94	75	43	10	8,40	8,71	117	75	10
4,30	2,94	80	47	10	8,50	8,71	117	75	10
4,40	2,94	80	47	10	8,60	9,50	125	81	10
4,50	2,94	80	47	10	8,70	9,50	125	81	10
4,60	2,94	80	47	10	8,75	9,51	125	81	10
4,70	2,94	80	47	10	8,80	9,50	125	81	10
4,75	3,17	80	47	10	8,90	9,50	125	81	10
4,80	3,17	86	52	10	9,00	9,51	125	81	10
4,90	3,18	86	52	10	9,10	10,73	125	81	10
5,00	3,03	86	52	10	9,20	10,73	125	81	10
5,10	3,64	86	52	10	9,25	10,72	125	81	10
5,20	3,64	86	52	10	9,30	10,73	125	81	10
5,25	3,64	86	52	10	9,40	10,73	125	81	10

(continúa Ref.1108 / suite Réf.1108 / Ref.1108 cont'd)

# BROCAS CON MANGO CILÍNDRICO CORTAS FORETS À QUEUE CYLINDRIQUE COURTES / SHORT STRAIGHT SHANK DRILL-BITS / KURZER ZYLINDERSCHAFT-BOHRER

(continúa Ref. 1108 / suite Réf.1108 / Ref.1108 cont'd)

Ø mm	€	L mm	l mm	
9,50	10,72	125	81	10
9,60	11,94	133	87	10
9,75	11,94	133	87	10
9,80	11,94	133	87	10
9,90	11,94	133	87	10
10,00	11,94	133	87	5

Ø mm	€	L mm	l mm	
10,50	13,79	133	87	5
11,00	15,42	142	94	5
11,50	17,12	142	94	5
12,00	19,66	151	101	5
12,50	20,78	151	101	5
13,00	22,68	151	101	5

**1103**

**HSS DIN 338 H**

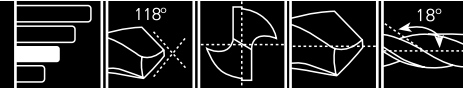

P				M		K			N				S		H		
<800	<1.000	<1.200	<1.400	<950	<1.200	<500	<800	<1.400	Al	Cu	Mg/Zn	Plastic	Ti	Ni	50 HRC	55 HRC	60 HRC
										25-60							

Vc (m/min). ● Optima / Optimun ○ Alternativo / Alternative



Ø mm	€	L mm	l mm	
1,00	4,06	34	12	1
1,25	4,58	38	16	1
1,50	3,98	40	18	1
1,75	4,46	46	22	1
2,00	3,64	49	24	1
2,25	4,26	53	27	1
2,50	3,71	57	30	1
2,75	4,98	61	33	1
3,00	4,06	61	33	1
3,25	4,98	65	36	1
3,50	4,38	70	39	1
3,75	6,46	70	39	1
4,00	4,70	75	43	1
4,25	7,03	75	43	1
4,50	5,79	80	47	1
4,75	7,93	80	47	1
5,00	6,30	86	52	1
5,25	9,49	86	52	1
5,50	7,62	93	57	1
5,75	11,60	93	57	1
6,00	8,26	93	57	1
6,25	11,60	101	63	1

Ø mm	€	L mm	l mm	
6,50	9,20	101	63	1
6,75	13,97	109	69	1
7,00	9,72	109	69	1
7,25	18,44	109	69	1
7,50	11,43	109	69	1
7,75	21,34	117	75	1
8,00	12,18	117	75	1
8,25	22,79	117	75	1
8,50	14,11	117	75	1
8,75	23,86	125	81	1
9,00	14,82	125	81	1
9,25	30,75	125	81	1
9,50	17,34	125	81	1
9,75	34,03	133	87	1
10,00	18,12	133	87	1
10,50	21,71	133	87	1
11,00	24,24	142	94	1
11,50	29,31	142	94	1
12,00	31,60	151	101	1
12,50	35,82	151	101	1
13,00	38,34	151	101	1



# BROCAS CON MANGO CILÍNDRICO CORTAS FORETS À QUEUE CYLINDRIQUE COURTES / SHORT STRAIGHT SHANK DRILL-BITS / KURZER ZYLINDERSCHAFT-BOHRER

## 1105 HSSCO DIN 338 N



P				M		K			N				S		H		
<800	<1.000	<1.200	<1.400	<950	<1.200	<500	<800	<1.400	Al	Cu	Mg/Zn	Plastic	Ni	Ti	50 HRC	55 HRC	60 HRC
●	●	●		○		●	●		○	●		○					
15-35	12-20	6-16		8-14		25-30	12-16		50-60	30-60		20-25					

Vc (m/min). ● Optima / Optimun ○ Alternativo / Alternative





Ø mm	€	L mm	l mm	Icon	Ø mm	€	L mm	l mm	Icon
0,50	2,97	22	6	10	4,80	2,83	86	52	10
0,60	2,41	24	7	10	4,90	2,85	86	52	10
0,70	2,34	28	9	10	5,00	2,35	86	52	10
0,75	2,34	28	9	10	5,10	2,88	86	52	10
0,80	2,12	30	10	10	5,20	2,89	86	52	10
0,90	2,12	32	11	10	5,25	2,95	86	52	10
1,00	1,86	34	12	10	5,30	2,95	86	52	10
1,10	1,61	36	14	10	5,40	3,40	93	57	10
1,20	1,79	38	16	10	5,50	3,72	93	57	10
1,25	2,12	38	16	10	5,60	3,72	93	57	10
1,30	1,70	38	16	10	5,70	3,72	93	57	10
1,40	1,60	40	18	10	5,75	3,72	93	57	10
1,50	1,70	40	18	10	5,80	3,72	93	57	10
1,60	1,77	43	20	10	5,90	3,72	93	57	10
1,70	1,63	43	20	10	6,00	3,18	93	57	10
1,75	2,39	46	22	10	6,10	4,13	101	63	10
1,80	1,63	46	22	10	6,20	4,17	101	63	10
1,90	1,69	46	22	10	6,25	4,17	101	63	10
2,00	1,74	49	24	10	6,30	4,17	101	63	10
2,10	1,90	49	24	10	6,40	4,48	101	63	10
2,20	1,90	53	27	10	6,50	4,13	101	63	10
2,25	2,75	53	27	10	6,60	4,48	101	63	10
2,30	1,90	53	27	10	6,70	4,48	101	63	10
2,40	1,91	57	30	10	6,75	4,82	109	69	10
2,50	1,86	57	30	10	6,80	4,82	109	69	10
2,60	1,99	57	30	10	6,90	4,82	109	69	10
2,70	1,99	61	33	10	7,00	4,36	109	69	10
2,75	2,05	61	33	10	7,10	5,88	109	69	10
2,80	2,01	61	33	10	7,20	5,88	109	69	10
2,90	2,05	61	33	10	7,25	5,88	109	69	10
3,00	1,55	61	33	10	7,30	5,88	109	69	10
3,10	2,05	65	36	10	7,40	5,88	109	69	10
3,20	2,05	65	36	10	7,50	4,63	109	69	10
3,25	2,07	65	36	10	7,60	7,13	117	75	10
3,30	2,16	65	36	10	7,70	7,13	117	75	10
3,40	2,19	70	39	10	7,75	7,13	117	75	10
3,50	2,05	70	39	10	7,80	7,13	117	75	10
3,60	2,25	70	39	10	7,90	7,13	117	75	10
3,70	2,27	70	39	10	8,00	5,79	117	75	10
3,75	2,46	70	39	10	8,10	7,13	117	75	10
3,80	2,29	75	43	10	8,20	7,13	117	75	10
3,90	2,35	75	43	10	8,25	6,84	117	75	10
4,00	2,01	75	43	10	8,30	7,13	117	75	10
4,10	2,39	75	43	10	8,40	7,13	117	75	10
4,20	2,41	75	43	10	8,50	5,68	117	75	10
4,25	2,35	75	43	10	8,60	8,36	125	81	10
4,30	2,57	80	47	10	8,70	8,36	125	81	10
4,40	2,63	80	47	10	8,75	8,69	125	81	10
4,50	2,46	80	47	10	8,80	8,69	125	81	10
4,60	2,69	80	47	10	8,90	8,69	125	81	10
4,70	2,75	80	47	10	9,00	7,19	125	81	10
4,75	2,73	80	47	10	9,10	9,31	125	81	10



# BROCAS CON MANGO CILÍNDRICO CORTAS FORETS À QUEUE CYLINDRIQUE COURTES / SHORT STRAIGHT SHANK DRILL-BITS / KURZER ZYLINDERSCHAFT-BOHRER

(continúa Ref.1105 / suite Réf.1105 / Ref.1105 cont'd)

Ø mm	€	L mm	l mm		Ø mm	€	L mm	l mm	
9,20	9,31	125	81	10	11,75	21,81	142	94	5
9,25	9,59	125	81	10	11,80	21,81	142	94	5
9,30	10,25	125	81	10	11,90	21,81	151	101	5
9,40	10,25	125	81	10	12,00	16,72	151	101	5
9,50	9,07	125	81	10	12,10	26,04	151	101	5
9,60	11,48	133	87	10	12,20	26,04	151	101	5
9,70	11,76	133	87	10	12,25	26,04	151	101	5
9,75	11,32	133	87	10	12,30	26,04	151	101	5
9,80	11,77	133	87	10	12,40	26,04	151	101	5
9,90	11,77	133	87	10	12,50	22,93	151	101	5
10,00	9,07	133	87	5	12,60	27,19	151	101	5
10,10	14,88	133	87	5	12,70	27,19	151	101	5
10,20	14,88	133	87	5	12,75	27,19	151	101	5
10,25	14,88	133	87	5	12,80	27,19	151	101	5
10,30	14,88	133	87	5	12,90	27,19	151	101	5
10,40	14,88	133	87	5	13,00	23,24	151	101	5
10,50	12,09	133	87	5	13,50	25,62	160	108	4
10,60	17,31	133	87	5	14,00	25,32	160	108	4
10,70	17,31	142	94	5	14,50	35,88	169	114	4
10,75	17,31	142	94	5	15,00	36,47	169	114	4
10,80	17,31	142	94	5	15,50	42,15	178	120	1
10,90	17,31	142	94	5	16,00	43,73	178	120	1
11,00	13,31	142	94	5	16,50	50,02	184	125	1
11,10	20,29	142	94	5	17,00	50,02	184	125	1
11,20	20,29	142	94	5	17,50	55,36	191	130	1
11,25	20,29	142	94	5	18,00	60,35	191	130	1
11,30	20,29	142	94	5	18,50	66,61	198	125	1
11,40	20,29	142	94	5	19,00	66,61	198	125	1
11,50	17,07	142	94	5	19,50	73,87	205	140	1
11,60	21,81	142	94	5	20,00	85,35	205	140	1
11,70	21,81	142	94	5					

1105/9

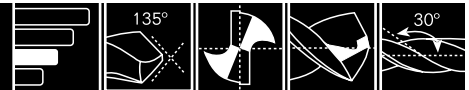

**HSSCO DIN 338 N**



P				M		K			N				S		H		
<800	<1.000	<1.200	<1.400	<950	<1.200	<500	<800	<1.400	Al	Cu	Mg/Zn	Plastic	Ti	Ni	50 HRC	55 HRC	60 HRC
● 15-35	● 12-20	● 6-16		○ 8-14		● 25-30	● 12-16		○ 50-60	● 30-60		○ 20-25					

Vc (m/min). ● Optima / Optimun ○ Alternativo / Alternative



Ø mm	€	L mm	l mm		Ø mm	€	L mm	l mm	
1/16"	1,69	43	20	10	19/64"	4,63	117	75	10
5/64"	1,74	49	24	10	5/16"	5,79	117	75	10
3/32"	1,86	57	30	10	21/64"	5,68	117	75	10
7/64"	2,05	61	33	10	11/32"	8,69	125	81	10
1/8"	1,55	65	36	10	23/64"	7,19	125	81	10
9/64"	2,05	70	39	10	3/8"	9,07	133	87	10
5/32"	2,01	75	43	10	25/64"	9,07	133	87	10
11/64"	2,46	80	47	10	13/32"	12,09	133	87	5
3/16"	2,46	86	52	10	27/64"	17,31	142	94	5
13/64"	2,35	86	52	10	7/16"	13,31	142	94	5
7/32"	3,72	93	57	10	29/64"	17,07	142	94	5
15/64"	3,18	93	57	10	15/32"	16,72	151	101	5
1/4"	4,13	101	63	10	31/64"	22,93	151	101	5
17/64"	4,82	109	69	10	1/2"	23,24	151	101	5
9/32"	4,36	109	69	10					

# BROCAS CON MANGO CILÍNDRICO CORTAS FORETS À QUEUE CYLINDRIQUE COURTES / SHORT STRAIGHT SHANK DRILL-BITS / KURZER ZYLINDERSCHAFT-BOHRER

1161

**HSSCO DIN 338 N**



P				M		K			N				S		H		
<800	<1.000	<1.200	<1.400	<950	<1.200	<500	<800	<1.400	Al	Cu	Mg/Zn	Plastic	Ni	Ti	50 HRC	55 HRC	60 HRC
● 25-50	● 18-30	● 10-25		○ 12-20		● 38-45	● 18-25		○ 70-80	● 45-80		○ 30-35					

Vc (m/min). ● Optima / Optimun ○ Alternativo / Alternative



Ø mm	€	L mm	l mm	
2,00	3,69	49	24	1
2,50	3,69	57	30	1
3,00	3,65	61	33	1
3,10	4,59	65	36	1
3,25	4,59	65	36	1
3,30	4,59	65	36	1
3,40	4,78	70	39	1
3,50	4,58	70	39	1
4,00	4,73	75	43	1
4,10	4,97	75	43	1
4,20	4,97	75	43	1
4,25	4,97	75	43	1
4,30	5,01	80	47	1
4,50	5,04	80	47	1
5,00	5,12	86	52	1
5,10	5,50	86	52	1
5,25	5,55	86	52	1

Ø mm	€	L mm	l mm	
5,50	5,80	93	57	1
6,00	6,02	93	57	1
6,50	11,08	101	63	1
7,00	11,73	109	69	1
7,50	12,02	109	69	1
8,00	12,82	117	75	1
8,50	14,28	117	75	1
9,00	15,84	125	81	1
9,50	16,10	125	81	1
10,00	16,90	133	87	1
10,50	29,11	133	87	1
11,00	30,33	142	94	1
11,50	32,19	142	94	1
12,00	33,27	151	101	1
12,50	41,14	151	101	1
13,00	41,82	151	101	1

1107

**HSSCO DIN 338 MR**



P				M		K			N				S		H		
<800	<1.000	<1.200	<1.400	<950	<1.200	<500	<800	<1.400	Al	Cu	Mg/Zn	Plastic	Ti	Ni	50 HRC	55 HRC	60 HRC
● 15-35	● 12-20	● 6-16		○ 8-14		● 25-30	● 12-16		○ 50-60	● 30-60		○ 20-25					

Vc (m/min). ● Optima / Optimun ○ Alternativo / Alternative

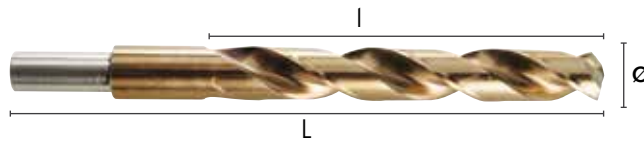

Ø mm	d mm	€	L mm	l mm	
10,00	8	10,78	133	87	1
10,50	8	14,43	133	87	1
11,00	8	15,55	142	94	1
11,50	8	19,09	142	94	1
12,00	8	20,24	151	101	1
12,50	8	24,56	151	101	1
13,00	10	24,90	151	101	1
13,50	10	27,13	160	108	1
14,00	10	26,85	160	108	1
14,50	10	36,77	169	114	1
15,00	10	37,29	169	114	1

Ø mm	d mm	€	L mm	l mm	
15,50	10	42,60	178	120	1
16,00	12	44,12	178	120	1
16,50	12	50,01	184	125	1
17,00	12	50,01	184	125	1
17,50	12	55,02	191	130	1
18,00	12	59,69	191	130	1
18,50	12	65,61	191	130	1
19,00	12	65,61	191	130	1
19,50	12	72,41	191	130	1
20,00	12	83,18	191	130	1

**BROCAS CON MANGO CILÍNDRICO CORTAS**  
**FORETS À QUEUE CYLINDRIQUE COURTES / SHORT STRAIGHT SHANK DRILL-BITS /**  
**KURZER ZYLINDERSCHAFT-BOHRER**

1107/9

**HSSCO ANSI**



P				M		K			N				S		H		
<800	<1.000	<1.200	<1.400	<950	<1.200	<500	<800	<1.400	Al	Cu	Mg/Zn	Plastic	Ni	Ti	50 HRC	55 HRC	60 HRC
●	●	●		○		●	●		○	●		○					
15-35	12-20	6-16		8-14		25-30	12-16		50-60	30-60		20-25					

Vc (m/min). ● Optima / Optimun ○ Alternativo / Alternative

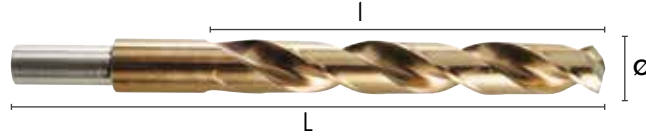

Ø mm	d mm	€	L mm	l mm	
17/32"	1/2"	27,13	152	76	1
9/16"	1/2"	26,85	152	76	1
19/32"	1/2"	37,29	152	76	1
5/8"	1/2"	44,12	152	76	1

Ø mm	d mm	€	L mm	l mm	
11/16"	1/2"	55,02	152	76	1
23/32"	1/2"	59,79	152	76	1
3/4"	1/2"	65,61	152	76	1
13/16"	1/2"	83,18	152	76	1

**BROCAS CON MANGO CILÍNDRICO CORTAS**  
**FORETS À QUEUE CYLINDRIQUE COURTES / SHORT STRAIGHT SHANK DRILL-BITS /**  
**KURZER ZYLINDERSCHAFT-BOHRER**

**1187**

**HSSCO DIN 338W**



P			M		K			N				S		H			
<800	<1.000	<1.200	<1.400	<950	<1.200	<500	<800	<1.400	Al	Cu	Mg/Zn	Plastic	Ni	Ti	50 HRC	55 HRC	60 HRC
●				●					○	○	○			●			
30-40				8-14					30-80	50-70	50-70			8-10			

Vc (m/min). ● Optima / Optimun ○ Alternativo / Alternative

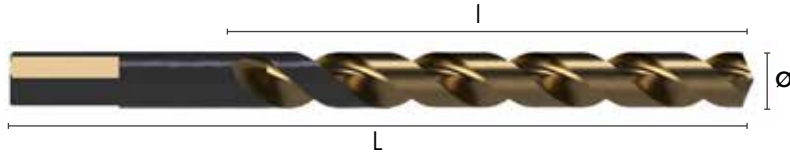

Ø mm	€	L mm	l mm	
1,00	3,06	34	12	10
1,25	3,66	38	16	10
1,50	2,92	40	18	10
1,75	3,66	46	22	10
2,00	2,92	49	24	10
2,25	3,23	53	27	10
2,50	2,66	57	30	10
2,75	3,23	61	33	10
3,00	2,60	61	33	10
3,20	3,19	65	36	10
3,25	3,19	65	36	10
3,30	3,19	65	36	10
3,50	3,14	70	39	10
3,75	3,78	70	39	10
4,00	3,41	75	43	10
4,20	3,78	75	43	10
4,25	3,78	75	43	10
4,50	3,78	80	47	10
4,75	4,23	80	47	10
5,00	4,06	86	52	10
5,20	5,04	86	52	10
5,25	4,75	86	52	10

Ø mm	€	L mm	l mm	
5,50	5,14	93	57	10
5,75	5,75	93	57	10
6,00	5,47	93	57	10
6,25	6,29	101	63	10
6,50	6,40	101	63	10
6,75	7,49	109	69	10
6,80	7,47	109	69	10
7,00	6,97	109	69	10
7,50	7,42	109	69	10
8,00	8,68	117	75	10
8,50	9,06	117	75	10
9,00	11,54	125	81	10
9,50	11,94	125	81	10
10,00	13,18	133	87	5
10,20	17,77	133	87	5
10,50	17,77	133	87	5
11,00	19,62	142	94	5
11,50	22,57	142	94	5
12,00	24,20	151	101	5
12,50	26,93	151	101	5
13,00	27,34	151	101	5

# BROCAS CON MANGO CILÍNDRICO CORTAS FORETS À QUEUE CYLINDRIQUE COURTES / SHORT STRAIGHT SHANK DRILL-BITS / KURZER ZYLINDERSCHAFT-BOHRER

1106

**HSSCO DIN 338 W**



P				M		K			N				S		H		
<800	<1.000	<1.200	<1.400	<950	<1.200	<500	<800	<1.400	Al	Cu	Mg/Zn	Plastic	Ni	Ti	50 HRC	55 HRC	60 HRC
				●					○	○	○			●			
				8-14					30-80	50-70	50-70			8-10			

Vc (m/min). ● Optima / Optimun ○ Alternativo / Alternative

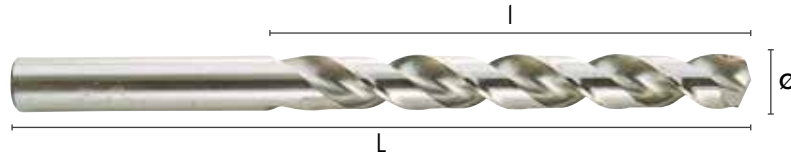

Ø mm	€	L mm	l mm	Icon	Ø mm	€	L mm	l mm	Icon
1,00	3,13	34	12	10	5,25	6,16	86	52	10
1,25	3,70	38	16	10	5,50	6,02	93	57	10
1,50	2,98	40	18	10	5,75	6,82	93	57	10
2,00	2,98	49	24	10	6,00	6,69	93	57	10
2,25	3,60	53	27	10	6,25	7,03	101	63	10
2,50	2,97	57	30	10	6,50	7,96	101	63	10
2,75	4,61	61	33	10	6,75	8,38	109	69	10
3,00	3,30	61	33	10	7,00	9,25	109	69	10
3,10	3,58	65	36	10	7,25	10,68	109	69	10
3,20	3,58	65	36	10	7,50	10,54	109	69	10
3,25	3,65	65	36	10	8,00	11,43	117	75	10
3,30	4,57	65	36	10	8,25	12,34	117	75	10
3,50	3,58	70	39	10	8,50	13,77	117	75	10
3,75	4,23	70	39	10	9,00	14,94	125	81	10
4,00	4,06	75	43	10	9,50	16,91	125	81	10
4,10	5,07	75	43	10	10,00	18,59	133	87	5
4,20	5,07	75	43	10	10,25	25,91	133	87	5
4,25	4,71	75	43	10	10,50	22,01	133	87	5
4,50	4,71	80	47	10	11,00	23,47	142	94	5
4,75	4,67	80	47	10	11,50	27,53	142	94	5
5,00	4,95	86	52	10	12,00	27,53	151	101	5
5,10	6,30	86	52	10	12,50	34,52	151	101	5
5,20	5,63	86	52	10	13,00	34,52	151	101	5

**BROCAS CON MANGO CILÍNDRICO CORTAS**  
**FORETS À QUEUE CYLINDRIQUE COURTES / SHORT STRAIGHT SHANK DRILL-BITS /**  
**KURZER ZYLINDERSCHAFT-BOHRER**

**1162**

**HSSCO DIN 338 W**



P				M		K			N				S		H		
<800	<1.000	<1.200	<1.400	<950	<1.200	<500	<800	<1.400	Al	Cu	Mg/Zn	Plastic	Ni	Ti	50 HRC	55 HRC	60 HRC
				●					○		○			●			
				12-20					45-100		75-95			12-15			

Vc (m/min). ● Optima / Optimun ○ Alternativo / Alternative

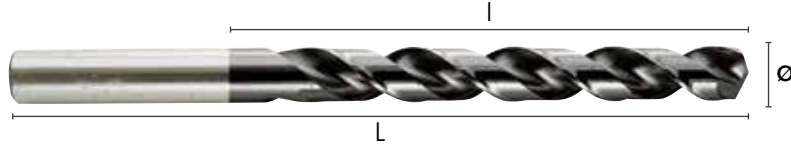

Ø mm	€	L mm	l mm	
1,00	5,95	34	12	1
1,25	7,05	38	16	1
1,50	5,66	40	18	1
2,00	5,66	49	24	1
2,25	6,86	53	27	1
2,50	5,64	57	30	1
2,75	8,78	61	33	1
3,00	6,29	61	33	1
3,10	6,83	65	36	1
3,20	6,83	65	36	1
3,25	6,94	65	36	1
3,30	8,66	65	36	1
3,50	6,84	70	39	1
3,75	8,07	70	39	1
4,00	7,74	75	43	1
4,10	9,61	75	43	1
4,20	9,61	75	43	1
4,25	8,98	75	43	1
4,50	8,98	80	47	1
4,75	8,89	80	47	1
5,00	9,42	86	52	1
5,10	11,99	86	52	1
5,20	10,72	86	52	1

Ø mm	€	L mm	l mm	
5,25	11,73	86	52	1
5,50	11,48	93	57	1
5,75	12,97	93	57	1
6,00	12,74	93	57	1
6,25	13,36	101	63	1
6,50	15,18	101	63	1
6,75	15,94	109	69	1
7,00	17,61	109	69	1
7,25	20,34	109	69	1
7,50	20,08	109	69	1
8,00	21,78	117	75	1
8,25	23,51	117	75	1
8,50	26,24	117	75	1
9,00	28,45	125	81	1
9,50	32,20	125	81	1
10,00	35,38	133	87	1
10,25	49,33	133	87	1
10,50	41,90	133	87	1
11,00	44,71	142	94	1
11,50	52,43	142	94	1
12,00	52,43	151	101	1
12,50	65,73	151	101	1
13,00	65,73	151	101	1



**BROCAS CON MANGO CILÍNDRICO CORTAS**  
**FORETS À QUEUE CYLINDRIQUE COURTES / SHORT STRAIGHT SHANK DRILL-BITS /**  
**KURZER ZYLINDERSCHAFT-BOHRER**

**1159 HSSCO DIN 338 S**



P				M		K			N				S		H		
<800	<1.000	<1.200	<1.400	<950	<1.200	<500	<800	<1.400	Al	Cu	Mg/Zn	Plastic	Ni	Ti	50 HRC	55 HRC	60 HRC
●	●	●		○					●		●						
15-30	12-20	6-16		8-14					30-80		50-70						

Vc (m/min). ● Optima / Optimun ○ Alternativo / Alternative

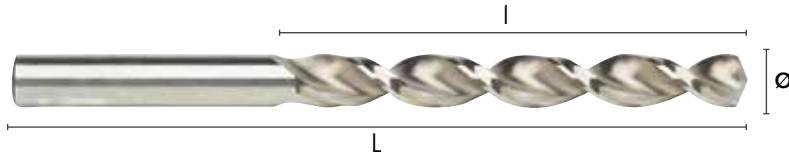

Ø mm	€	L mm	l mm	Icon	Ø mm	€	L mm	l mm	Icon
2,00	3,99	49	24	10	6,00	8,64	93	57	10
2,10	3,83	49	24	10	6,10	9,59	101	63	10
2,20	3,83	53	27	10	6,20	9,59	101	63	10
2,30	3,83	53	27	10	6,30	9,65	101	63	10
2,40	3,83	57	30	10	6,40	9,65	101	63	10
2,50	3,99	57	30	10	6,50	9,65	101	63	10
2,60	4,12	57	30	10	6,60	11,05	101	63	10
2,70	4,12	61	33	10	6,70	11,05	101	63	10
2,80	4,36	61	33	10	6,80	11,05	109	69	10
2,90	4,36	61	33	10	6,90	11,05	109	69	10
3,00	4,36	61	33	10	7,00	11,05	109	69	10
3,10	4,44	65	36	10	7,10	13,39	109	69	10
3,20	4,44	65	36	10	7,20	13,39	109	69	10
3,30	4,44	65	36	10	7,30	13,39	109	69	10
3,40	4,44	70	39	10	7,40	13,39	109	69	10
3,50	4,96	70	39	10	7,50	11,97	109	69	10
3,60	4,85	70	39	10	7,60	18,27	117	75	10
3,70	4,85	70	39	10	7,70	18,27	117	75	10
3,80	5,61	75	43	10	7,80	18,27	117	75	10
3,90	5,61	75	43	10	7,90	18,27	117	75	10
4,00	5,43	75	43	10	8,00	14,11	117	75	10
4,10	5,61	75	43	10	8,10	18,27	117	75	10
4,20	5,61	75	43	10	8,20	16,00	117	75	10
4,30	5,73	80	47	10	8,30	17,18	117	75	10
4,40	5,73	80	47	10	8,40	17,18	117	75	10
4,50	5,79	80	47	10	8,50	15,54	117	75	10
4,60	6,18	80	47	10	8,60	19,71	125	81	10
4,70	6,18	80	47	10	8,70	19,71	125	81	10
4,80	6,37	86	52	10	8,80	19,71	125	81	10
4,90	6,37	86	52	10	8,90	19,71	125	81	10
5,00	6,13	86	52	10	9,00	18,27	125	81	10
5,10	6,92	86	52	10	9,50	19,68	125	81	10
5,20	7,24	86	52	10	9,80	24,70	133	87	10
5,30	7,24	86	52	10	10,00	22,45	133	87	5
5,40	7,24	93	57	10	10,50	27,62	133	87	5
5,50	8,20	93	57	10	11,00	34,20	142	94	5
5,60	8,66	93	57	10	11,50	41,48	142	94	5
5,70	9,65	93	57	10	12,00	42,79	151	101	5
5,80	8,66	93	57	10	12,50	46,69	151	101	5
5,90	8,66	93	57	10	13,00	46,69	151	101	5



**BROCAS CON MANGO CILÍNDRICO CORTAS**  
**FORETS À QUEUE CYLINDRIQUE COURTES / SHORT STRAIGHT SHANK DRILL-BITS /**  
**KURZER ZYLINDERSCHAFT-BOHRER**

**1160**

**HSSCO DIN 338 S**

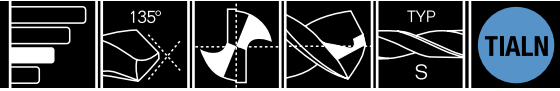

P				M		K			N				S		H		
<800	<1.000	<1.200	<1.400	<950	<1.200	<500	<800	<1.400	Al	Cu	Mg/Zn	Plastic	Ni	Ti	50 HRC	55 HRC	60 HRC
●	●	●		○					●		●						
25-45	18-30	10-25		12-20					45-100		70-90						

Vc (m/min). ● Optima / Optimun ○ Alternativo / Alternative



Ø mm	€	L mm	l mm		Ø mm	€	L mm	l mm	
2,00	5,59	49	24	1	6,00	12,09	93	57	1
2,10	5,37	49	24	1	6,10	13,42	101	63	1
2,20	5,37	53	27	1	6,20	13,42	101	63	1
2,30	5,37	53	27	1	6,30	13,49	101	63	1
2,40	5,37	57	30	1	6,40	13,49	101	63	1
2,50	5,59	57	30	1	6,50	13,49	101	63	1
2,60	5,76	57	30	1	6,60	15,47	101	63	1
2,70	5,76	61	33	1	6,70	15,47	101	63	1
2,80	6,10	61	33	1	6,80	15,47	109	69	1
2,90	6,10	61	33	1	6,90	15,47	109	69	1
3,00	6,10	61	33	1	7,00	15,16	109	69	1
3,10	6,23	65	36	1	7,10	18,74	109	69	1
3,20	6,23	65	36	1	7,20	18,74	109	69	1
3,30	6,23	65	36	1	7,30	18,74	109	69	1
3,40	6,23	70	39	1	7,40	18,74	109	69	1
3,50	6,93	70	39	1	7,50	16,75	109	69	1
3,60	6,81	70	39	1	7,60	25,60	117	75	1
3,70	6,81	70	39	1	7,70	25,60	117	75	1
3,80	7,85	75	43	1	7,80	25,60	117	75	1
3,90	7,85	75	43	1	7,90	25,60	117	75	1
4,00	7,59	75	43	1	8,00	19,76	117	75	1
4,10	7,85	75	43	1	8,10	25,60	117	75	1
4,20	7,85	75	43	1	8,20	22,39	117	75	1
4,30	8,02	80	47	1	8,30	25,60	117	75	1
4,40	8,12	80	47	1	8,40	25,60	117	75	1
4,50	8,12	80	47	1	8,50	21,74	117	75	1
4,60	8,65	80	47	1	8,60	27,60	125	81	1
4,70	8,65	80	47	1	8,70	27,60	125	81	1
4,80	8,93	86	52	1	8,80	27,60	125	81	1
4,90	8,93	86	52	1	8,90	27,60	125	81	1
5,00	8,56	86	52	1	9,00	25,60	125	81	1
5,10	9,69	86	52	1	9,50	27,56	125	81	1
5,20	10,15	86	52	1	9,80	34,59	133	87	1
5,30	10,15	86	52	1	10,00	31,42	133	87	1
5,40	10,15	93	57	1	10,50	38,68	133	87	1
5,50	11,49	93	57	1	11,00	47,86	142	94	1
5,60	12,15	93	57	1	11,50	58,08	142	94	1
5,70	13,49	93	57	1	12,00	59,89	151	101	1
5,80	12,15	93	57	1	12,50	62,06	151	101	1
5,90	12,15	93	57	1	13,00	65,38	151	101	1

**BROCAS CON MANGO CILÍNDRICO CORTAS**  
**FORETS À QUEUE CYLINDRIQUE COURTES / SHORT STRAIGHT SHANK DRILL-BITS /**  
**KURZER ZYLINDERSCHAFT-BOHRER**

**1110 HSS DIN 338 N - WIDIA**

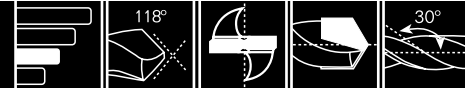

P				M		K			N				S		H		
<800	<1.000	<1.200	<1.400	<950	<1.200	<500	<800	<1.400	Al	Cu	Mg/Zn	Plastic	Ni	Ti	50 HRC	55 HRC	60 HRC
●	●	●	○				●	●				○					
25-45	18-30	10-25	6-9				30-40	15-20				30-35					

Vc (m/min). ● Optima / Optimun ○ Alternativo / Alternative

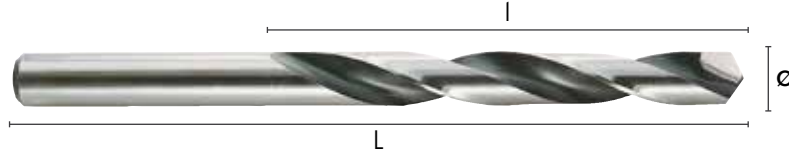

Ø mm	€	L mm	l mm	
1,50	28,67	40	18	1
2,00	21,78	49	24	1
2,50	21,78	57	30	1
3,00	21,78	61	33	1
3,50	21,78	70	39	1
4,00	21,78	75	43	1
4,50	22,27	80	47	1
5,00	22,27	86	52	1
5,50	23,55	93	57	1
6,00	24,70	93	57	1
6,50	29,31	101	63	1
7,00	29,31	109	69	1
7,50	30,48	109	69	1
8,00	30,48	117	75	1
8,50	33,35	117	75	1

Ø mm	€	L mm	l mm	
9,00	33,35	125	81	1
9,50	36,45	125	81	1
10,00	36,45	133	87	1
10,50	46,98	133	87	1
11,00	46,98	142	97	1
12,00	54,06	151	101	1
13,00	64,59	151	101	1
14,00	75,26	160	108	1
15,00	85,71	169	114	1
16,00	98,69	178	120	1
17,00	108,05	184	125	1
18,00	116,34	191	130	1
19,00	144,48	198	135	1
20,00	164,47	205	140	1

# BROCAS CON MANGO CILÍNDRICO LARGAS FORETS À QUEUE CYLINDRIQUE LONGUES / LONG STRAIGHT SHANK DRILL-BITS / LANGER ZYLINDERSCHAFT-BOHRER

## 1112 HSS DIN 340 N



P				M		K			N				S		H		
<800	<1.000	<1.200	<1.400	<950	<1.200	<500	<800	<1.400	Al	Cu	Mg/Zn	Plastic	Ni	Ti	50 HRC	55 HRC	60 HRC
●				●		●	●		○	●		○					
15-35						25-30	12-16		50-60	30-60		20-25					

Vc (m/min). ● Optima / Optimun ○ Alternativo / Alternative

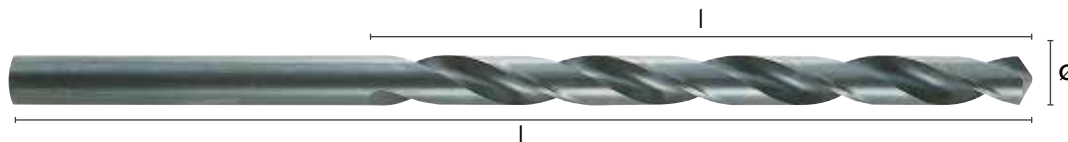



Ø mm	€	L mm	l mm	📦	Ø mm	€	L mm	l mm	📦
1,00	3,42	56	33	10	5,25	5,81	132	87	10
1,10	4,14	60	37	10	5,30	6,39	132	87	10
1,20	4,14	65	41	10	5,40	6,39	139	91	10
1,25	3,76	65	41	10	5,50	5,25	139	91	10
1,30	4,14	65	41	10	5,60	6,39	139	91	10
1,40	4,14	70	45	10	5,70	6,39	139	91	10
1,50	3,42	70	45	10	5,75	5,81	139	91	10
1,60	3,52	76	50	10	5,80	6,39	139	91	10
1,70	3,21	76	50	10	5,90	6,39	139	91	10
1,75	3,21	80	53	10	6,00	5,14	139	91	10
1,80	3,52	80	53	10	6,10	8,11	148	97	10
1,90	3,52	80	53	10	6,20	8,11	148	97	10
2,00	2,94	85	56	10	6,25	7,37	148	97	10
2,10	3,52	85	56	10	6,30	8,11	148	97	10
2,20	3,52	85	56	10	6,40	8,84	148	97	10
2,25	3,21	90	59	10	6,50	6,71	148	97	10
2,30	3,52	90	59	10	6,60	8,11	148	97	10
2,40	3,52	95	62	10	6,70	8,11	148	97	10
2,50	2,94	95	62	10	6,75	7,37	156	102	10
2,60	3,52	100	66	10	6,80	9,37	156	102	10
2,70	3,52	100	66	10	6,90	9,37	156	102	10
2,75	3,21	100	66	10	7,00	6,71	156	102	10
2,80	3,52	100	66	10	7,10	9,91	156	102	10
2,90	3,52	100	66	10	7,20	9,91	156	102	10
3,00	2,66	100	66	10	7,25	9,03	156	102	10
3,10	4,20	106	69	10	7,30	9,91	156	102	10
3,20	4,20	106	69	10	7,40	9,91	156	102	10
3,25	3,82	106	69	10	7,50	8,19	156	102	10
3,30	4,20	106	69	10	7,60	9,91	165	109	10
3,40	4,20	112	73	10	7,70	9,91	165	109	10
3,50	3,47	112	73	10	7,75	9,03	165	109	10
3,60	4,20	112	73	10	7,80	9,91	165	109	10
3,70	4,20	112	73	10	7,90	9,91	165	109	10
3,75	3,82	112	73	10	8,00	8,19	165	109	10
3,80	4,20	119	78	10	8,10	12,22	165	109	10
3,90	4,20	119	78	10	8,20	12,22	165	109	10
4,00	3,24	119	78	10	8,25	11,11	165	109	10
4,10	5,36	119	78	10	8,30	12,22	165	109	10
4,20	5,36	119	78	10	8,40	12,22	165	109	10
4,25	4,89	119	78	10	8,50	10,08	165	109	10
4,30	5,36	126	82	10	8,75	11,11	175	115	10
4,40	5,36	126	82	10	8,80	12,22	175	115	10
4,50	4,52	126	82	10	8,90	12,74	175	115	10
4,60	5,36	126	82	10	9,00	10,08	175	115	10
4,70	5,36	126	82	10	9,25	12,91	175	115	10
4,75	4,89	126	82	10	9,30	14,24	175	115	10
4,80	5,36	132	87	10	9,40	14,24	175	115	10
4,90	5,36	132	87	10	9,50	11,78	175	115	10
5,00	4,18	132	87	10	9,70	14,24	184	121	10
5,10	6,39	132	87	10	9,75	12,91	184	121	10
5,20	6,39	132	87	10	9,90	14,24	184	121	10

(continúa Ref.1112 / suite Réf.1112 / Ref.1112 cont'd)

# BROCAS CON MANGO CILÍNDRICO LARGAS FORETS À QUEUE CYLINDRIQUE LONGUES / LONG STRAIGHT SHANK DRILL-BITS / LANGER ZYLINDERSCHAFT-BOHRER

(continúa Ref.1112 / suite Réf.1112 / Ref.1112 cont'd)

∅ mm	€	L mm	l mm	
10,00	11,78	184	121	5
10,25	17,66	184	121	5
10,30	25,13	184	121	5
10,40	19,44	184	121	5
10,50	16,08	184	121	5
10,75	17,66	195	128	5
11,00	16,08	195	128	5
11,10	23,04	195	128	5
11,20	23,04	195	128	5
11,25	20,96	195	128	5
11,50	19,06	195	128	5
11,75	20,96	195	128	5
12,00	19,06	205	134	5
12,25	25,21	205	134	5
12,50	22,91	205	134	5
12,75	25,21	205	134	5
13,00	22,91	205	134	5

∅ mm	€	L mm	l mm	
13,25	31,48	214	140	1
13,50	28,62	214	140	1
13,75	31,48	214	140	1
14,00	28,62	214	140	1
14,50	31,88	220	144	1
15,00	31,88	220	144	1
15,50	34,84	227	149	1
16,00	34,84	227	149	1
16,50	47,82	235	154	1
17,00	47,82	235	154	1
17,50	52,76	241	158	1
18,00	52,76	241	158	1
18,50	60,08	247	162	1
19,00	60,08	247	162	1
19,50	64,94	254	166	1
20,00	64,94	254	166	1

1113

**HSSCO DIN 340 N**



P				M		K			N				S		H		
<800	<1.000	<1.200	<1.400	<950	<1.200	<500	<800	<1.400	Al	Cu	Mg/Zn	Plastic	Ni	Ti	50 HRC	55 HRC	60 HRC
● 15-35	● 12-20	● 6-16		○ 8-14		● 25-30	● 12-16		○ 50-60	● 30-60		○ 20-25					

Vc (m/min). ● Optima / Optimun ○ Alternativo / Alternative

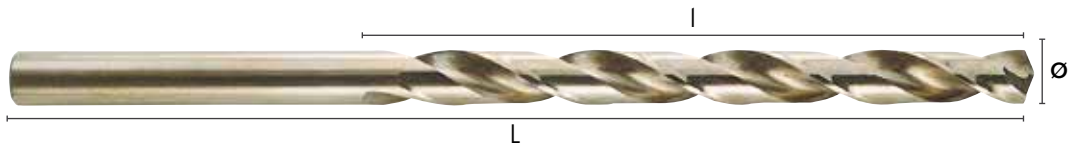

∅ mm	€	L mm	l mm	
2,00	6,97	85	56	10
2,50	6,97	95	62	10
3,00	6,97	100	66	10
3,25	12,16	106	69	10
3,50	8,28	112	73	10
3,75	8,28	112	73	10
4,00	8,28	119	78	10
4,25	9,61	119	78	10
4,50	10,61	126	82	10
4,75	13,18	126	82	10
5,00	10,61	132	87	10
5,25	23,12	132	87	10
5,50	11,62	139	91	10
5,75	15,71	139	91	10
6,00	11,62	139	91	10

∅ mm	€	L mm	l mm	
6,50	14,74	148	97	10
7,00	16,03	156	102	10
7,50	19,62	156	102	10
8,00	18,02	165	109	10
8,50	22,27	165	109	10
9,00	22,27	175	115	10
9,50	25,92	175	115	10
10,00	34,93	184	121	5
10,50	43,97	184	121	5
11,00	45,63	195	128	5
11,50	59,18	195	128	5
12,00	49,03	205	134	5
12,50	62,55	205	134	5
13,00	62,55	204	134	5

# BROCAS CON MANGO CILÍNDRICO LARGAS FORETS À QUEUE CYLINDRIQUE LONGUES / LONG STRAIGHT SHANK DRILL-BITS / LANGER ZYLINDERSCHAFT-BOHRER

1114

**HSSCO DIN 340 S**



P				M		K			N				S		H		
<800	<1.000	<1.200	<1.400	<950	<1.200	<500	<800	<1.400	Al	Cu	Mg/Zn	Plastic	Ni	Ti	50 HRC	55 HRC	60 HRC
● 15-30	● 12-20	● 6-16		○ 8-14					● 30-80		● 50-70						

Vc (m/min). ● Optima / Optimun ○ Alternativo / Alternative



Ø mm	€	L mm	l mm	
2,00	9,65	85	56	1
2,10	8,96	85	56	1
2,30	9,31	90	59	1
2,50	9,65	95	62	1
2,70	9,82	100	66	1
3,00	10,01	100	66	1
3,10	11,49	106	69	1
3,20	11,49	106	69	1
3,30	11,49	106	69	1
3,50	11,13	112	73	1
3,60	12,14	112	73	1
3,70	12,42	112	73	1
4,00	11,05	119	78	1
4,10	14,28	119	78	1
4,20	14,28	119	78	1
4,30	16,05	126	82	1
4,50	12,78	126	82	1
4,70	15,88	126	82	1
4,80	16,61	132	87	1
5,00	13,75	132	87	1
5,10	17,27	132	87	1
5,20	17,24	132	87	1
5,50	15,93	139	91	1

Ø mm	€	L mm	l mm	
5,60	20,44	139	91	1
5,80	20,94	139	91	1
6,00	16,95	139	91	1
6,20	25,91	148	97	1
6,50	21,02	148	97	1
6,80	32,97	156	102	1
7,00	25,96	156	102	1
7,20	32,50	156	102	1
7,50	29,85	156	102	1
8,00	29,85	165	109	1
8,20	35,33	165	109	1
8,50	34,76	165	109	1
8,80	37,68	175	115	1
9,00	36,23	175	115	1
9,50	47,44	175	115	1
9,80	65,00	184	121	1
10,00	48,47	184	121	1
10,50	75,39	184	121	1
11,00	56,75	195	128	1
11,50	105,35	195	128	1
12,00	78,28	195	128	1
13,00	97,53	195	128	1

**BROCAS CON MANGO CILÍNDRICO LARGAS**  
**FORETS À QUEUE CYLINDRIQUE LONGUES / LONG STRAIGHT SHANK DRILL-BITS /**  
**LANGER ZYLINDERSCHAFT-BOHRER**

**1164 HSSCO DIN 340 S**



P				M		K			N				S		H		
<800	<1.000	<1.200	<1.400	<950	<1.200	<500	<800	<1.400	Al	Cu	Mg/Zn	Plastic	Ni	Ti	50 HRC	55 HRC	60 HRC
●	●	●		○					●		●						
25-45	18-30	10-25		12-20					45-100		70-90						

Vc (m/min). ● Optima / Optimun ○ Alternativo / Alternative



Ø mm	€	L mm	l mm	📦
2,00	12,44	85	56	1
2,10	11,54	85	56	1
2,30	11,99	90	59	1
2,50	12,44	95	62	1
2,70	12,65	100	66	1
3,00	12,87	100	66	1
3,10	14,80	106	69	1
3,20	14,80	106	69	1
3,30	14,80	106	69	1
3,50	14,34	112	73	1
3,60	15,62	112	73	1
3,70	16,00	112	73	1
4,00	14,21	119	78	1
4,10	18,41	119	78	1
4,20	18,41	119	78	1
4,30	20,67	126	82	1
4,50	16,47	126	82	1
4,70	20,46	126	82	1
4,80	21,40	132	87	1
5,00	17,69	132	87	1
5,10	22,23	132	87	1
5,20	22,20	132	87	1
5,50	20,51	139	91	1

Ø mm	€	L mm	l mm	📦
5,60	26,35	139	91	1
5,80	26,96	139	91	1
6,00	21,84	139	91	1
6,20	33,37	148	97	1
6,50	27,07	148	97	1
6,80	42,47	156	102	1
7,00	33,42	156	102	1
7,20	41,86	156	102	1
7,50	38,45	156	102	1
8,00	38,45	165	109	1
8,20	45,51	165	109	1
8,50	44,75	165	109	1
8,80	48,55	175	115	1
9,00	46,65	175	115	1
9,50	61,11	175	115	1
9,80	83,72	184	121	1
10,00	62,43	184	121	1
10,50	97,10	184	121	1
11,00	73,10	195	128	1
11,50	135,71	195	128	1
12,00	100,83	195	128	1
13,00	125,62	195	128	1

**BROCAS CON MANGO CILÍNDRICO EXTRA LARGAS**  
**FORETS À QUEUE CYLINDRIQUE EXTRA LONGUES / EXTRA-LONG STRAIGHT**  
**SHANK DRILL-BITS / BOHRER MIT EXTRA LANGEM ZYLINDERSCHAFT**

**1115**

**HSS DIN 1869 N**

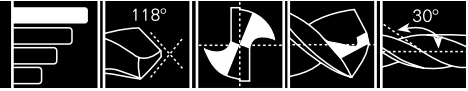

P				M		K			N				S		H		
<800	<1.000	<1.200	<1.400	<950	<1.200	<500	<800	<1.400	Al	Cu	Mg/Zn	Plastic	Ni	Ti	50 HRC	55 HRC	60 HRC
●						●	●		○	●		○					
15-35						25-30	12-16		50-60	30-60		20-25					

Vc (m/min). ● Optima / Optimun ○ Alternativo / Alternative

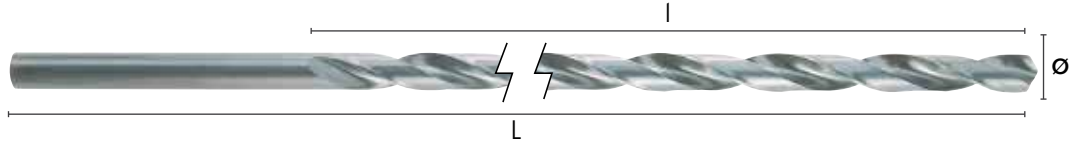

Ø mm	€	L mm	l mm	
2,00	12,74	125	85	1
2,50	13,31	140	95	1
3,00	13,76	150	100	1
3,00	14,71	190	130	1
3,50	15,53	165	115	1
3,50	17,89	210	145	1
3,50	25,62	265	180	1
4,00	15,53	175	120	1
4,00	18,33	220	150	1
4,00	26,11	280	190	1
4,50	17,20	185	125	1
4,50	21,51	235	160	1
4,50	30,76	295	200	1
5,00	18,20	195	135	1
5,00	23,11	245	170	1
5,00	28,43	315	210	1
5,50	21,56	205	140	1
5,50	30,76	260	180	1
5,50	35,54	330	235	1
6,00	21,56	205	140	1
6,00	30,76	260	180	1
6,00	35,54	330	225	1
6,50	25,62	215	150	1
6,50	33,10	275	190	1
6,50	41,26	350	235	1
7,00	27,16	225	155	1
7,00	37,81	290	210	1
7,00	51,09	370	250	1
7,50	30,58	225	155	1
7,50	40,73	290	200	1
7,50	59,36	370	250	1
8,00	33,79	240	165	1

Ø mm	€	L mm	l mm	
8,00	46,78	305	210	1
8,00	60,92	390	265	1
8,50	45,97	240	165	1
8,50	62,65	305	210	1
8,50	86,16	390	265	1
9,00	43,84	250	175	1
9,00	57,89	320	220	1
9,00	84,98	410	280	1
9,50	51,61	250	175	1
9,50	70,95	320	220	1
9,50	95,57	410	280	1
10,00	50,94	265	185	1
10,00	66,63	340	235	1
10,00	92,59	430	295	1
10,50	97,09	265	145	1
10,50	105,22	340	250	1
10,50	111,90	430	295	1
11,00	64,50	280	195	1
11,00	94,47	365	250	1
11,00	110,60	455	310	1
11,50	90,41	280	195	1
11,50	121,37	365	250	1
11,50	125,40	455	310	1
12,00	85,17	295	205	1
12,00	106,58	375	260	1
12,00	130,20	480	315	1
12,50	105,22	295	205	1
12,50	117,82	375	260	1
12,50	143,03	480	315	1
13,00	105,22	295	205	1
13,00	121,39	375	260	1
13,00	144,38	480	315	1



**BROCAS CON MANGO CILÍNDRICO EXTRA LARGAS**  
**FORETS À QUEUE CYLINDRIQUE EXTRA LONGUES / EXTRA-LONG STRAIGHT**  
**SHANK DRILL-BITS / BOHRER MIT EXTRA LANGEM ZYLINDERSCHAFT**

**1165 HSSCO DIN 1869 S**

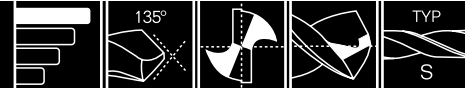

P				M		K			N				S		H		
<800	<1.000	<1.200	<1.400	<950	<1.200	<500	<800	<1.400	Al	Cu	Mg/Zn	Plastic	Ni	Ti	50 HRC	55 HRC	60 HRC
●	●			○					●		●						
15-30	12-20			8-14					30-80		50-70						

Vc (m/min). ● Optima / Optimun ○ Alternativo / Alternative

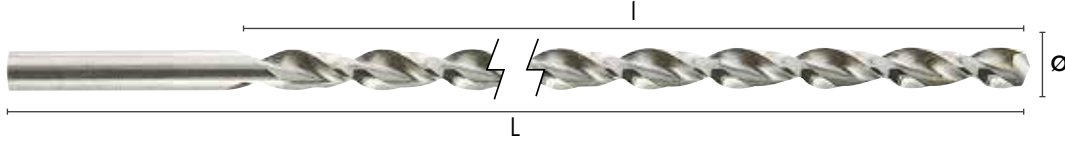

Ø mm	€	L mm	l mm	
2,00	19,15	125	85	1
2,50	20,89	140	95	1
3,00	20,89	150	100	1
3,00	24,39	190	130	1
3,00	38,32	240	160	1
3,50	22,64	165	115	1
3,50	26,12	210	145	1
3,50	34,84	265	180	1
4,00	24,39	175	120	1
4,00	29,62	220	150	1
4,00	34,84	280	190	1
4,50	26,12	185	125	1
4,50	33,10	235	160	1
4,50	38,32	295	200	1
5,00	27,87	195	135	1
5,00	34,84	245	170	1
5,00	41,81	315	210	1
5,50	31,35	205	140	1
5,50	40,05	260	180	1
5,50	47,03	330	225	1
6,00	29,62	205	140	1
6,00	36,58	260	180	1
6,00	45,30	330	225	1
6,50	33,10	215	150	1
6,50	41,81	275	190	1
6,50	55,72	350	235	1
7,00	38,32	225	155	1
7,00	45,30	290	200	1
7,00	60,97	370	250	1
7,50	41,81	225	155	1

Ø mm	€	L mm	l mm	
7,50	50,51	290	200	1
7,50	66,19	370	250	1
8,00	47,03	240	165	1
8,00	55,72	305	210	1
8,00	80,14	390	265	1
8,50	48,77	240	165	1
8,50	59,21	305	210	1
8,50	83,61	390	265	1
9,00	57,47	250	175	1
9,00	69,67	320	220	1
9,00	97,55	410	280	1
9,50	59,21	250	175	1
9,50	69,67	320	220	1
9,50	102,78	410	280	1
10,00	66,19	265	185	1
10,00	92,32	340	235	1
10,00	113,21	430	295	1
10,50	69,67	265	185	1
10,50	97,55	340	235	1
10,50	116,71	430	295	1
11,00	76,63	280	195	1
11,00	106,24	365	250	1
11,00	130,63	455	310	1
11,50	87,09	280	195	1
11,50	120,18	365	250	1
11,50	146,31	455	310	1
12,00	95,79	295	205	1
12,00	130,63	375	260	1
12,00	161,99	480	330	1



# BROCAS CON MANGO CILÍNDRICO EXTRA CORTAS FORETS À QUEUE CYLINDRIQUE EXTRA-COURTES EXTRA-SHORT STRAIGHT SHANK DRILL-BITS / BOHRER MIT EXTRA KURZEM ZYLINDERSCHAFT

1116

**HSS DIN 1897 N**

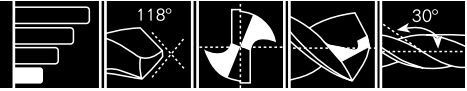

P				M		K			N				S		H		
<800	<1.000	<1.200	<1.400	<950	<1.200	<500	<800	<1.400	Al	Cu	Mg/Zn	Plastic	Ni	Ti	50 HRC	55 HRC	60 HRC
●						●	●		○	●		○					
15-35						25-30	12-16		50-60	30-60		20-25					

Vc (m/min). ● Optima / Optimun ○ Alternativo / Alternative

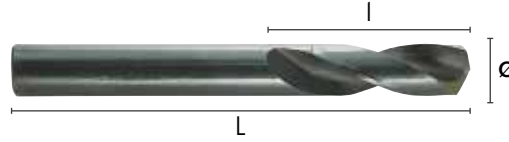

Ø mm	€	L mm	l mm	📦	Ø mm	€	L mm	l mm	📦
1,00	1,30	26	6	10	5,10	2,52	62	26	10
1,10	2,88	28	7	10	5,20	2,52	62	26	10
1,20	3,33	30	8	10	5,25	2,07	62	26	10
1,25	1,18	30	8	10	5,30	2,53	62	26	10
1,30	3,83	30	8	10	5,40	2,53	66	28	10
1,40	4,39	32	9	10	5,50	2,07	66	28	10
1,50	1,14	32	9	10	5,60	2,73	66	28	10
1,60	2,61	34	10	10	5,70	4,10	66	28	10
1,70	3,02	34	10	10	5,75	2,37	66	28	10
1,75	1,14	36	11	10	5,80	2,73	66	28	10
1,80	3,02	36	11	10	5,90	2,88	66	28	10
1,90	3,02	36	11	10	6,00	2,37	66	28	10
2,00	1,14	38	12	10	6,10	3,41	70	31	10
2,10	1,40	38	12	10	6,20	3,41	70	31	10
2,20	1,40	40	13	10	6,25	2,83	70	31	10
2,25	1,14	40	13	10	6,30	3,41	70	31	10
2,30	1,40	40	13	10	6,40	3,41	70	31	10
2,40	1,40	43	14	10	6,50	2,83	70	31	10
2,50	1,14	43	14	10	6,60	3,96	70	31	10
2,60	1,90	43	14	10	6,70	3,96	70	31	10
2,70	1,30	46	16	10	6,75	3,26	74	34	10
2,75	1,19	46	16	10	6,80	3,96	74	34	10
2,80	1,43	46	16	10	6,90	3,96	74	34	10
2,90	1,43	46	16	10	7,00	3,26	74	34	10
3,00	1,19	46	16	10	7,25	3,70	74	34	10
3,10	1,55	49	18	10	7,50	3,70	74	34	10
3,20	1,55	49	18	10	7,75	4,06	79	37	10
3,25	1,29	49	18	10	8,00	4,06	79	37	10
3,30	1,47	49	18	10	8,25	4,85	79	37	10
3,40	1,55	52	20	10	8,50	4,85	79	37	10
3,50	1,29	52	20	10	8,75	5,36	84	40	10
3,60	1,72	52	20	10	9,00	5,30	84	40	10
3,70	1,72	52	20	10	9,25	5,64	84	40	10
3,75	1,39	52	20	10	9,50	5,93	84	40	10
3,80	1,72	55	22	10	9,75	6,63	89	43	10
3,90	1,72	55	22	10	10,00	6,63	89	43	5
4,00	1,39	55	22	10	10,50	7,44	89	43	5
4,10	2,01	55	22	10	11,00	8,31	95	47	5
4,20	2,01	55	22	10	11,50	9,24	95	47	5
4,25	1,69	55	22	10	12,00	9,74	102	51	5
4,30	2,01	58	24	10	13,00	11,99	102	51	5
4,40	2,01	58	24	10	14,00	16,50	107	54	4
4,50	1,69	58	24	10	15,00	21,50	111	56	4
4,60	2,29	58	24	10	16,00	25,91	115	58	1
4,70	2,29	58	24	10	17,00	30,45	119	60	1
4,75	1,88	58	24	10	18,00	33,92	123	62	1
4,80	2,29	62	26	10	19,00	37,81	127	64	1
4,90	2,29	62	26	10	20,00	45,34	131	66	1
5,00	1,88	62	26	10					



# BROCAS CON MANGO CILÍNDRICO EXTRA CORTAS FORETS À QUEUE CYLINDRIQUE EXTRA-COURTES EXTRA-SHORT STRAIGHT SHANK DRILL-BITS / BOHRER MIT EXTRA KURZEM ZYLINDERSCHAFT

## 1117 HSS DIN 1897 N

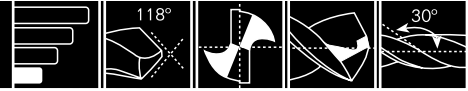

P				M		K			N				S		H		
<800	<1.000	<1.200	<1.400	<950	<1.200	<500	<800	<1.400	Al	Cu	Mg/Zn	Plastic	Ni	Ti	50 HRC	55 HRC	60 HRC
●	●	●		○		●	●		○	●		○					
15-35						25-30	12-16		50-60	30-60		20-25					

Vc (m/min). ● Optima / Optimun ○ Alternativo / Alternative



Ø mm	€	L mm	l mm	Icon
2,00	2,49	38	9	10
2,25	2,49	40	9	10
2,50	2,49	43	10	10
2,75	2,49	46	10	10
3,00	2,16	46	10	10
3,25	2,16	49	10	10
3,30	2,16	49	10	10
3,50	2,41	52	13	10
3,75	2,76	52	13	10
4,00	2,48	55	13	10
4,10	2,67	55	13	10
4,20	2,67	55	13	10

Ø mm	€	L mm	l mm	Icon
4,25	2,67	55	13	10
4,50	2,76	58	13	10
4,75	4,46	58	13	10
4,80	3,04	58	13	10
5,00	3,16	62	13	10
5,25	4,46	62	13	10
5,50	3,81	66	16	10
5,75	5,27	66	16	10
6,00	4,26	66	16	10
7,00	5,63	74	19	10
8,00	6,90	79	19	10

## 1118 HSSCO DIN 1897 N

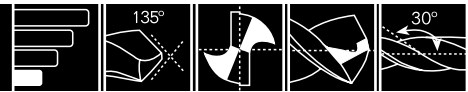

P				M		K			N				S		H		
<800	<1.000	<1.200	<1.400	<950	<1.200	<500	<800	<1.400	Al	Cu	Mg/Zn	Plastic	Ni	Ti	50 HRC	55 HRC	60 HRC
●	●	●		○		●	●		○	●		○					
15-35	12-20	6-16		8-14		25-30	12-16		50-60	30-60		20-25					

Vc (m/min). ● Optima / Optimun ○ Alternativo / Alternative



Ø mm	€	L mm	l mm	Icon
2,00	1,51	38	12	10
2,20	2,63	40	13	10
2,25	2,06	40	13	10
2,50	2,15	43	14	10
2,70	3,63	46	16	10
2,75	2,27	46	16	10
3,00	2,27	46	16	10
3,20	2,87	49	18	10
3,25	2,23	49	18	10
3,30	2,97	49	18	10
3,50	2,41	52	20	10
3,75	2,52	52	20	10
4,00	2,65	55	22	10
4,10	4,83	55	22	10
4,20	3,66	55	22	10
4,25	2,87	55	22	10
4,50	3,05	58	24	10
4,75	3,16	58	24	10
4,90	3,83	62	26	10
5,00	3,41	62	26	10
5,10	4,27	62	26	10

Ø mm	€	L mm	l mm	Icon
5,20	4,16	62	26	10
5,25	3,25	62	26	10
5,50	3,56	66	28	10
5,75	3,69	66	28	10
6,00	3,84	66	28	10
6,50	4,39	70	31	10
6,75	7,49	74	34	10
7,00	4,92	74	34	10
7,50	6,24	74	34	10
8,00	6,93	79	37	10
8,25	8,83	79	37	10
8,50	7,49	79	37	10
9,00	8,31	84	40	10
9,50	8,97	84	40	10
10,00	9,95	89	43	5
10,50	14,97	89	43	5
11,00	13,82	95	47	5
11,50	15,51	95	47	5
12,00	19,04	102	51	5
12,50	19,97	102	51	5
13,00	26,10	102	51	5

**BROCAS CON MANGO CILÍNDRICO EXTRA CORTAS**  
**FORETS À QUEUE CYLINDRIQUE EXTRA-COURTES EXTRA-SHORT STRAIGHT SHANK**  
**DRILL-BITS / BOHRER MIT EXTRA KURZEM ZYLINDERSCHAFT**

1166

**HSSCO DIN 1897 S**

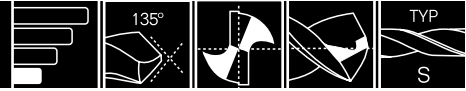

P				M		K			N				S		H		
<800	<1.000	<1.200	<1.400	<950	<1.200	<500	<800	<1.400	Al	Cu	Mg/Zn	Plastic	Ni	Ti	50 HRC	55 HRC	60 HRC
●	●	●							●		●						
15-30	12-20	6-16							30-80		50-70						

Vc (m/min). ● Optima / Optimun ○ Alternativo / Alternative

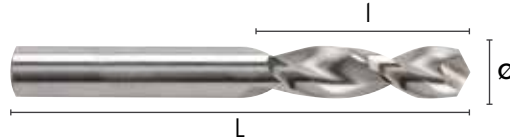

Ø mm	€	L mm	l mm	
2,00	4,40	38	12	10
2,50	3,96	43	14	10
2,80	3,99	46	16	10
3,00	3,82	46	16	10
3,10	4,24	49	18	10
3,20	4,24	49	18	10
3,30	4,24	49	18	10
3,40	4,24	52	20	10
3,50	4,24	52	20	10
3,60	5,16	52	20	10
3,70	5,16	52	20	10
3,80	5,37	55	22	10
3,90	5,16	55	22	10
4,00	4,70	55	22	10
4,10	5,59	55	22	10
4,20	5,59	55	22	10
4,30	6,43	58	24	10
4,40	6,43	58	24	10
4,50	5,59	58	24	10
4,60	6,69	58	24	10
4,70	6,71	58	24	10
4,80	6,71	62	26	10
4,90	6,69	62	26	10
5,00	6,22	62	26	10
5,10	7,61	62	26	10
5,20	7,61	62	26	10
5,30	7,61	62	26	10
5,40	7,60	66	28	10
5,50	6,94	66	28	10
5,60	8,01	66	28	10

Ø mm	€	L mm	l mm	
5,70	8,34	66	28	10
5,80	8,01	66	28	10
5,90	8,01	66	28	10
6,00	7,91	66	28	10
6,10	10,17	66	28	10
6,20	10,13	70	31	10
6,50	9,46	70	31	10
6,80	13,18	70	31	10
7,00	10,83	74	34	10
7,20	13,74	74	34	10
7,50	13,98	74	34	10
7,80	13,98	74	34	10
8,00	13,62	79	37	10
8,20	12,03	79	37	10
8,50	16,15	79	37	10
8,80	23,64	79	37	10
9,00	17,62	84	40	10
9,20	19,85	84	40	10
9,50	19,85	84	40	10
9,80	22,06	84	40	10
10,00	22,06	89	43	10
10,50	23,99	89	43	5
11,00	27,50	89	43	5
11,50	30,54	95	47	5
12,00	32,18	95	47	5
13,00	39,64	102	51	5
14,00	51,09	102	51	5
15,00	56,57	107	54	4
16,00	65,69	111	56	4



**BROCAS CON MANGO CILÍNDRICO EXTRA CORTAS**  
**FORETS À QUEUE CYLINDRIQUE EXTRA-COURTES EXTRA-SHORT STRAIGHT SHANK**  
**DRILL-BITS / BOHRER MIT EXTRA KURZEM ZYLINDERSCHAFT**

**1167**

**HSSCO DIN 1897 S**



P				M		K			N				S		H		
<800	<1.000	<1.200	<1.400	<950	<1.200	<500	<800	<1.400	Al	Cu	Mg/Zn	Plastic	Ni	Ti	50 HRC	55 HRC	60 HRC
●	●	●		○					●		●						
25-45	18-30	10-25		12-20					45-100		70-90						

Vc (m/min). ● Optima / Optimun ○ Alternativo / Alternative

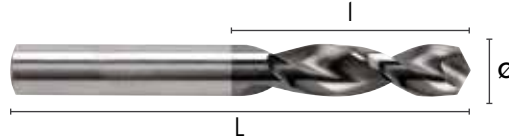

Ø mm	€	L mm	l mm	📦
2,00	6,17	38	12	1
2,50	5,58	43	14	1
2,80	5,58	46	16	1
3,00	5,34	46	16	1
3,10	5,94	49	18	1
3,20	5,94	49	18	1
3,30	5,94	49	18	1
3,40	5,94	52	20	1
3,50	5,94	52	20	1
3,60	7,24	52	20	1
3,70	7,24	52	20	1
3,80	7,53	55	22	1
3,90	7,24	55	22	1
4,00	6,59	55	22	1
4,10	7,80	55	22	1
4,20	7,80	55	22	1
4,30	9,01	58	24	1
4,40	9,01	58	24	1
4,50	7,80	58	24	1
4,60	9,39	58	24	1
4,70	9,40	58	24	1
4,80	9,40	62	26	1
4,90	9,39	62	26	1
5,00	8,73	62	26	1
5,10	10,63	62	26	1
5,20	10,63	62	26	1
5,30	10,63	62	26	1
5,40	10,63	66	28	1
5,50	9,72	66	28	1
5,60	11,23	66	28	1

Ø mm	€	L mm	l mm	📦
5,70	11,67	66	28	1
5,80	11,23	66	28	1
5,90	11,23	66	28	1
6,00	11,07	66	28	1
6,10	14,21	70	31	1
6,20	14,20	70	31	1
6,50	13,21	70	31	1
6,80	18,44	74	34	1
7,00	15,18	74	34	1
7,20	19,25	74	34	1
7,50	19,58	74	34	1
7,80	19,59	79	37	1
8,00	19,07	79	37	1
8,20	16,85	79	37	1
8,50	22,61	79	37	1
8,80	33,08	84	40	1
9,00	24,67	84	40	1
9,20	27,79	84	40	1
9,50	27,79	84	40	1
9,80	30,88	89	43	1
10,00	30,88	89	43	1
10,50	33,58	89	43	1
11,00	38,50	95	47	1
11,50	42,75	95	47	1
12,00	45,08	102	51	1
13,00	55,50	102	51	1
14,00	71,52	107	54	1
15,00	79,18	111	56	1
16,00	91,98	115	58	1

**1121**



**HSS DIN 345 N**

P				M		K			N				S		H		
<800	<1.000	<1.200	<1.400	<950	<1.200	<500	<800	<1.400	Al	Cu	Mg/Zn	Plastic	Ni	Ti	50 HRC	55 HRC	60 HRC
●				●		●	●		○	●		○					
15-35						25-30	12-16		50-60	30-60		20-25					

Vc (m/min). ● Optima / Optimun ○ Alternativo / Alternative

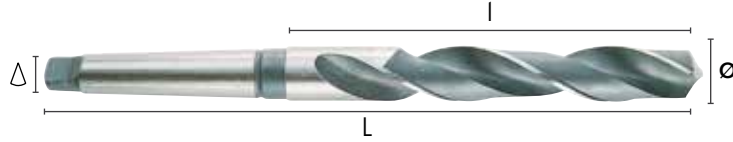



▶	△	Ø	€	L	l	📦
		mm		mm	mm	
1		5,00	19,21	133	52	1
1		5,25	22,12	133	52	1
1		5,50	19,21	138	57	1
1		5,75	22,12	138	57	1
1		6,00	19,21	138	57	1
1		6,25	25,20	144	63	1
1		6,50	21,88	144	63	1
1		6,75	25,20	150	69	1
1		7,00	21,88	150	69	1
1		7,25	27,05	150	69	1
1		7,50	23,53	150	69	1
1		7,75	27,05	156	75	1
1		8,00	23,53	156	75	1
1		8,25	31,75	156	75	1
1		8,50	21,23	156	75	1
1		8,75	31,75	162	81	1
1		9,00	21,23	162	81	1
1		9,25	32,80	162	81	1
1		9,50	20,97	162	81	1
1		9,75	32,80	168	87	1
1		10,00	20,97	168	87	1
1		10,25	33,47	168	87	1
1		10,50	22,39	168	87	1
1		10,75	33,47	175	94	1
1		11,00	22,39	175	94	1
1		11,25	35,26	175	94	1
1		11,50	23,60	175	94	1
1		11,75	35,26	175	94	1
1		12,00	23,60	182	101	1
1		12,25	39,27	182	101	1
1		12,50	26,26	182	101	1
1		12,75	39,27	182	101	1
1		13,00	26,26	182	101	1
1		13,25	43,17	189	108	1
1		13,50	28,87	189	108	1
1		13,75	43,17	189	108	1
1		14,00	28,87	189	108	1
2		14,25	46,71	212	114	1
2		14,50	31,26	212	114	1
2		14,75	46,71	212	114	1
2		15,00	31,26	212	114	1
2		15,25	48,40	218	120	1
2		15,50	32,34	218	120	1
2		15,75	48,40	218	120	1
2		16,00	32,34	218	120	1
2		16,25	54,71	223	125	1
2		16,50	36,59	223	125	1
2		16,75	54,71	223	125	1
2		17,00	36,59	223	125	1
2		17,25	60,57	228	130	1
2		17,50	40,49	228	130	1



▶	△	Ø	€	L	l	📦
		mm		mm	mm	
2		17,75	60,57	228	130	1
2		18,00	40,49	228	130	1
2		18,25	66,64	233	135	1
2		18,50	44,57	233	135	1
2		18,75	66,64	233	135	1
2		19,00	44,57	233	135	1
2		19,25	72,56	238	140	1
2		19,50	48,51	238	140	1
2		19,75	72,56	238	140	1
2		20,00	48,51	238	140	1
2		20,25	75,20	243	145	1
2		20,50	52,43	243	145	1
2		20,75	75,20	243	145	1
2		21,00	52,43	243	145	1
2		21,25	82,93	248	150	1
2		21,50	57,88	248	150	1
2		21,75	82,93	248	150	1
2		22,00	57,88	248	150	1
2		22,25	91,84	248	150	1
2		22,50	63,31	253	155	1
2		22,75	90,78	253	155	1
2		23,00	63,31	253	155	1
3		23,25	100,12	276	155	1
3		23,50	69,88	276	155	1
3		23,75	100,12	281	160	1
3		24,00	69,88	281	160	1
3		24,25	109,21	281	160	1
3		24,50	76,17	281	160	1
3		24,75	109,21	281	160	1
3		25,00	76,17	281	160	1
3		25,25	118,82	286	165	1
3		25,50	82,89	286	165	1
3		25,75	118,82	286	165	1
3		26,00	82,89	286	165	1
3		26,25	128,67	286	165	1
3		26,50	89,76	286	165	1
3		26,75	128,67	291	170	1
3		27,00	92,16	291	170	1
3		27,25	137,72	291	170	1
3		27,50	96,11	291	170	1
3		27,75	137,72	291	170	1
3		28,00	96,11	291	170	1
3		28,25	147,71	296	175	1
3		28,50	103,04	296	175	1
3		28,75	147,71	296	175	1
3		29,00	103,04	296	175	1
3		29,25	162,41	296	175	1
3		29,50	113,13	296	175	1
3		29,75	162,41	296	175	1
3		30,00	113,30	296	175	1
3		30,25	180,72	301	180	1

(continúa Ref.1121 / suite Réf.1121 / Ref.1121 cont'd)



(continúa Ref.1121 / suite Réf.1121 / Ref.1121 cont'd)

		Ø mm	€	L mm	l mm	
3		30,50	157,16	301	180	1
3		30,75	180,72	301	180	1
3		31,00	126,11	301	180	1
3		31,25	191,40	301	180	1
3		31,50	157,24	301	180	1
3		31,75	191,40	306	185	1
4		32,00	133,53	334	185	1
4		32,50	190,06	334	185	1
4		33,00	152,49	334	185	1
4		33,50	206,66	334	185	1
4		34,00	165,86	339	190	1
4		34,50	225,86	339	190	1
4		35,00	181,26	339	190	1
4		35,50	242,37	339	190	1
4		36,00	194,41	344	195	1
4		36,50	255,48	344	195	1
4		37,00	204,97	344	195	1
4		37,50	268,73	344	195	1
4		38,00	215,65	349	200	1
4		38,50	286,55	349	200	1
4		39,00	229,95	349	200	1
4		39,50	302,61	349	200	1
4		40,00	242,80	349	200	1
4		40,50	318,15	354	205	1
4		41,00	255,28	354	205	1
4		41,50	337,64	354	205	1
4		42,00	270,88	354	205	1
4		42,50	354,09	354	205	1
4		43,00	284,12	359	210	1
4		43,50	370,76	359	210	1
4		44,00	297,45	359	210	1
4		44,50	387,08	359	210	1
4		45,00	308,92	359	210	1
4		45,50	403,45	364	215	1
4		46,00	323,68	364	215	1
4		46,50	419,87	364	215	1
4		47,00	336,91	364	215	1

		Ø mm	€	L mm	l mm	
4		47,50	433,99	364	215	1
4		48,00	348,21	369	220	1
4		48,50	450,64	369	220	1
4		49,00	361,58	369	220	1
4		49,50	467,05	369	220	1
4		50,00	364,70	369	220	1
5		51,00	473,99	412	225	1
5		52,00	503,14	412	225	1
5		53,00	545,04	412	225	1
5		54,00	559,85	417	230	1
5		55,00	561,10	417	230	1
5		56,00	661,16	417	230	1
5		57,00	705,82	422	235	1
5		58,00	705,82	422	235	1
5		59,00	721,91	422	235	1
5		60,00	694,50	422	235	1
5		61,00	773,66	427	240	1
5		62,00	791,70	427	240	1
5		63,00	850,59	427	240	1
5		64,00	886,31	432	245	1
5		65,00	847,88	432	245	1
5		66,00	966,18	432	245	1
5		67,00	994,78	432	245	1
5		68,00	1.025,44	437	250	1
5		69,00	1.052,07	437	250	1
5		70,00	1.084,77	437	250	1
5		71,00	1.028,50	437	250	1
5		72,00	1.187,51	442	255	1
5		73,00	1.212,07	442	255	1
5		74,00	1.243,80	442	255	1
5		75,00	1.280,18	442	255	1
5		76,00	1.205,89	447	260	1
6		77,00	1.419,95	514	260	1
6		78,00	1.523,81	514	260	1
6		79,00	1.553,56	514	260	1
6		*80,00	1.584,85	514	260	1

\*(Hasta fin de existencias / Jusqu'à épuisement des stocks / While supplies last)

**1121/9**

**HSS DIN 345 N**



P				M		K			N				S		H		
<800	<1.000	<1.200	<1.400	<950	<1.200	<500	<800	<1.400	Al	Cu	Mg/Zn	Plastic	Ni	Ti	50 HRC	55 HRC	60 HRC
●						●	●		○	●		○					
15-35						25-30	12-16		50-60	30-60		20-25					

Vc (m/min). ● Optima / Optimun ○ Alternativo / Alternative

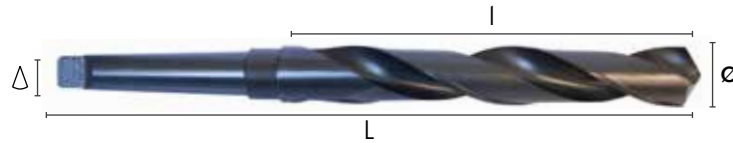

Ø mm	€	L mm	l mm	
1/2"	26,26	182	101	1
33/64"	26,26	182	101	1
17/32"	28,87	189	108	1
35/64"	28,87	189	108	1
9/16"	31,26	212	114	1
37/64"	46,71	212	114	1
19/32"	31,26	218	120	1
39/64"	32,34	218	120	1
5/8"	32,34	218	120	1
41/64"	54,71	223	125	1
21/32"	36,59	223	125	1
43/64"	36,59	223	125	1
11/16"	40,49	228	130	1
45/64"	40,49	228	130	1
23/32"	66,64	233	135	1
47/64"	44,57	233	135	1
3/4"	44,57	238	140	1
49/64"	48,51	238	140	1
25/32"	72,56	238	140	1
51/64"	48,51	243	145	1
13/16"	52,43	243	145	1
53/64"	52,43	243	145	1
27/32"	57,88	248	150	1
55/64"	82,93	248	150	1
7/8"	57,88	248	150	1
57/64"	63,31	253	155	1

Ø mm	€	L mm	l mm	
29/32"	63,31	253	155	1
59/64"	69,88	276	155	1
15/16"	137,72	281	160	1
61/64"	69,88	281	160	1
31/32"	57,88	281	160	1
63/64"	76,17	286	160	1
1"	84,16	290	170	1
1-1/16"	92,16	291	170	1
1-1/8"	103,04	296	175	1
1-5/32"	103,04	296	175	1
1-3/16"	113,30	301	180	1
1-7/32"	126,11	301	180	1
1-1/4"	191,40	306	185	1
1-9/32"	190,06	334	185	1
1-5/16"	152,49	334	185	1
1-11/32"	165,86	339	190	1
1-3/8"	181,26	339	190	1
1-13/32"	194,41	344	195	1
1-7/16"	255,48	344	195	1
1-1/2"	215,65	349	200	1
1-9/16"	242,80	349	200	1
1-5/8"	255,28	354	205	1
1-11/16"	284,12	359	210	1
1-3/4"	297,45	359	210	1
2"	364,70	374	225	1



**1123**

**HSS DIN 345 N - WIDIA**



P				M		K			N				S		H		
<800	<1.000	<1.200	<1.400	<950	<1.200	<500	<800	<1.400	Al	Cu	Mg/Zn	Plastic	Ni	Ti	50 HRC	55 HRC	60 HRC
●	●	●	○				●	●				○					
25-45	18-30	10-25	6-9				30-40	15-20				30-35					

Vc (m/min). ● Optima / Optimun ○ Alternativo / Alternative

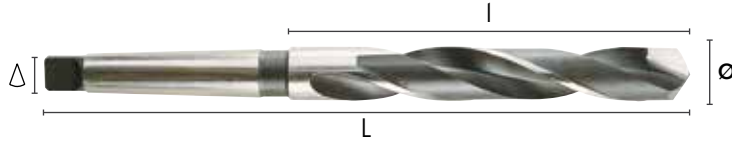

△	Ø mm	€	L mm	l mm	📦
1	10,00	85,10	168	87	1
1	11,00	92,05	175	94	1
1	12,00	96,58	182	101	1
1	13,00	109,76	182	101	1
1	14,00	119,32	189	108	1
1	14,50	134,81	212	114	1
2	15,00	134,81	212	114	1
2	15,50	144,00	218	120	1
2	16,00	144,00	218	120	1
2	16,50	152,75	223	125	1
2	17,00	152,75	223	125	1
2	17,50	164,84	228	130	1
2	18,00	164,84	228	130	1
2	18,50	192,95	233	135	1
2	19,00	192,95	233	135	1

△	Ø mm	€	L mm	l mm	📦
2	19,50	216,85	238	140	1
2	20,00	216,28	238	140	1
2	20,50	220,01	243	145	1
2	21,00	220,01	243	145	1
2	21,50	240,17	248	150	1
2	22,00	240,17	248	150	1
2	22,50	261,13	253	155	1
2	23,00	261,13	253	155	1
3	24,00	286,97	281	160	1
3	25,00	293,82	281	160	1
3	26,00	330,31	286	165	1
3	27,00	352,21	291	170	1
3	28,00	390,03	291	170	1
3	29,00	415,19	296	175	1
3	30,00	441,77	296	175	1



**1122**

**HSSCO DIN 345 N**



P				M		K			N				S		H		
<800	<1.000	<1.200	<1.400	<950	<1.200	<500	<800	<1.400	Al	Cu	Mg/Zn	Plastic	Ni	Ti	50 HRC	55 HRC	60 HRC
●	●	●		○		●	●		○	●		●					
15-35	12-20	6-16		8-14		25-30	12-16		50-60	30-60		15-25					

Vc (m/min). ● Optima / Optimun ○ Alternativo / Alternative



▶	△	Ø mm	€	L mm	l mm	📦
1		10,00	70,73	168	87	1
1		10,50	73,71	168	87	1
1		11,00	70,68	175	94	1
1		11,50	73,71	175	94	1
1		12,00	75,60	182	101	1
1		12,50	80,00	182	101	1
1		13,00	77,63	182	101	1
1		13,50	101,46	189	108	1
1		14,00	99,52	189	108	1
2		14,50	110,45	212	114	1
2		15,00	101,46	212	114	1
2		15,50	112,41	218	120	1
2		16,00	108,47	218	120	1
2		16,50	113,40	223	125	1
2		17,00	112,41	223	125	1
2		17,50	119,44	228	130	1
2		18,00	117,44	228	130	1
2		18,50	128,36	233	135	1
2		19,00	125,40	233	135	1
2		19,50	144,33	238	140	1
2		20,00	140,30	238	140	1
2		20,50	161,22	243	145	1
2		21,00	163,19	243	145	1
2		21,50	184,15	248	150	1
2		22,00	166,08	248	150	1
2		22,50	204,99	253	155	1

▶	△	Ø mm	€	L mm	l mm	📦
2		23,00	193,15	253	155	1
3		23,50	204,99	276	155	1
3		24,00	206,98	281	160	1
3		24,50	220,96	281	160	1
3		25,00	218,63	281	160	1
3		25,50	270,78	286	165	1
3		26,00	256,59	286	165	1
3		26,50	284,61	286	165	1
3		27,00	284,61	291	170	1
3		27,50	340,33	291	170	1
3		28,00	314,87	291	170	1
3		28,50	348,33	296	175	1
3		29,00	321,88	296	175	1
3		29,50	356,31	296	175	1
3		30,00	328,71	296	175	1
3		31,00	328,70	301	180	1
4		32,00	376,66	334	185	1
4		33,00	430,20	334	185	1
4		34,00	511,19	339	190	1
4		35,00	511,19	339	190	1
4		36,00	548,50	344	195	1
4		37,00	566,90	344	195	1
4		38,00	631,44	349	200	1
4		39,00	648,55	349	200	1
4		40,00	684,93	349	200	1



**1181**

**HSSCO (8%)**



P				M		K			N				S		H		
<800	<1.000	<1.200	<1.400	<950	<1.200	<500	<800	<1.400	Al	Cu	Mg/Zn	Plastic	Ni	Ti	50 HRC	55 HRC	60 HRC
		● 8-10	● 6-8										● 4-7		● 4-6		

Vc (m/min). ● Optima / Optimun ○ Alternativo / Alternative



△	Ø mm	€	L mm	l mm	📦
2	10	59,30	190	90	1
2	11	59,30	190	90	1
2	12	64,95	190	90	1
2	13	64,95	190	90	1
2	14	69,14	190	90	1
2	15	70,50	190	90	1
2	16	83,88	190	90	1
2	17	89,42	190	90	1
2	18	90,77	190	90	1
3	19	103,13	225	105	1
3	20	109,65	225	105	1
3	21	119,40	225	105	1
3	22	137,27	225	105	1

△	Ø mm	€	L mm	l mm	📦
3	24	147,87	225	105	1
3	25	175,23	225	105	1
3	26	207,64	225	105	1
4	27	223,30	265	120	1
4	28	231,88	265	120	1
4	30	257,92	265	120	1
4	32	300,18	265	120	1
4	35	375,06	265	120	1
4	36	394,47	265	120	1
4	40	495,91	265	120	1
4	45	674,45	265	120	1
5	50	792,32	340	150	1

**1125**

**HSS DIN 341 N**

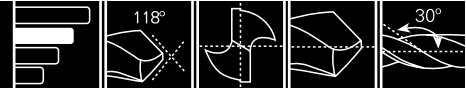

P				M		K			N				S		H		
<800	<1.000	<1.200	<1.400	<950	<1.200	<500	<800	<1.400	Al	Cu	Mg/Zn	Plastic	Ni	Ti	50 HRC	55 HRC	60 HRC
●						●	●		○	●		○					
15-35						25-30	12-16		50-60	30-60		20-25					

Vc (m/min). ● Optima / Optimun ○ Alternativo / Alternative

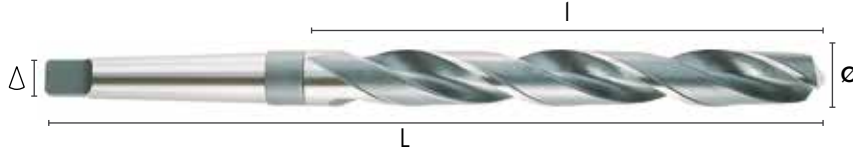

▶	△	Ø mm	€	L mm	l mm	📦
1		*5,00	26,77	155	74	1
1		*5,50	36,19	161	80	1
1		*6,00	28,56	161	80	1
1		*6,50	30,10	167	86	1
1		*7,00	31,82	174	93	1
1		*7,50	33,21	174	93	1
1		8,00	33,52	181	100	1
1		8,50	33,52	181	100	1
1		9,00	36,70	188	107	1
1		9,50	40,93	188	107	1
1		10,00	39,74	197	116	1
1		10,50	39,97	197	116	1
1		11,00	39,04	206	125	1
1		11,50	39,04	206	125	1
1		12,00	41,56	215	134	1
1		12,50	43,17	215	134	1
1		13,00	43,17	215	134	1
1		13,50	45,15	223	142	1
1		14,00	49,03	223	142	1
1		14,50	61,69	245	147	1
2		15,00	61,69	245	147	1
2		15,50	63,09	251	153	1
2		16,00	64,12	251	153	1
2		16,50	67,76	257	159	1
2		17,00	68,12	257	159	1
2		17,50	66,48	263	165	1
2		18,00	73,88	263	165	1
2		18,50	75,91	269	171	1
2		19,00	78,31	269	171	1
2		19,50	82,21	275	177	1
2		20,00	83,22	275	177	1

▶	△	Ø mm	€	L mm	l mm	📦
2		20,50	95,40	282	184	1
2		21,00	92,47	282	184	1
2		21,50	112,57	289	191	1
2		22,00	107,44	289	191	1
2		22,50	117,10	296	198	1
2		23,00	111,61	296	198	1
3		23,50	138,86	319	198	1
3		24,00	136,76	327	206	1
3		24,50	145,23	327	206	1
3		25,00	139,19	327	206	1
3		25,50	165,04	335	214	1
3		26,00	155,76	335	214	1
3		26,50	170,24	335	214	1
3		27,00	165,74	343	222	1
3		27,50	200,53	343	222	1
3		28,00	182,08	343	222	1
3		28,50	238,20	351	230	1
3		29,00	194,48	351	230	1
3		29,50	238,20	351	230	1
3		30,00	219,17	351	230	1
3		31,00	251,27	360	239	1
4		32,00	260,52	397	248	1
4		33,00	291,44	397	248	1
4		34,00	339,30	406	257	1
4		35,00	335,95	406	257	1
4		36,00	389,14	416	267	1
4		37,00	404,31	416	267	1
4		38,00	433,04	426	277	1
4		39,00	439,78	426	277	1
4		40,00	475,64	426	277	1

\*(Hasta fin de existencias / Jusqu'à épuisement des stocks / While supplies last)

**1126**

**HSS DIN 1870 N**

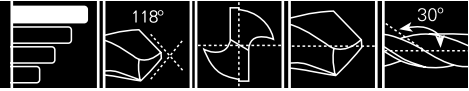

P				M		K			N				S		H		
<800	<1.000	<1.200	<1.400	<950	<1.200	<500	<800	<1.400	Al	Cu	Mg/Zn	Plastic	Ni	Ti	50 HRC	55 HRC	60 HRC
●						●	●		○	●		○					
15-35						25-30	12-16		50-60	30-60		20-25					

Vc (m/min). ● Optima / Optimun ○ Alternativo / Alternative

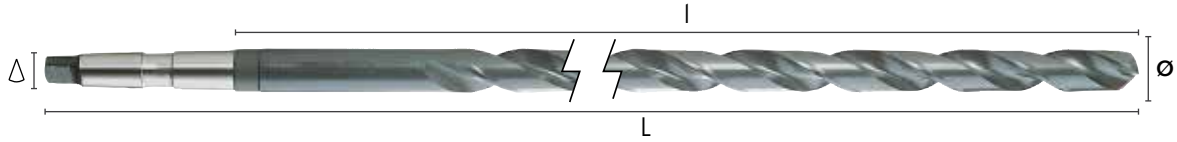

△	Ø mm	€	L mm	l mm	📦	△	Ø mm	€	L mm	l mm	📦
1	8,00	84,11	265	165	1	2	20,00	255,09	385	260	1
1	8,00	104,84	330	210	1	2	20,00	310,06	490	325	1
1	8,50	92,33	265	165	1	2	20,50	288,91	385	260	1
1	8,50	107,14	330	210	1	2	20,50	346,94	490	325	1
1	9,00	95,06	275	175	1	2	21,00	288,91	385	260	1
1	9,00	120,87	345	220	1	2	21,00	346,94	490	325	1
1	9,50	101,76	275	175	1	2	21,50	308,09	405	270	1
1	9,50	122,13	345	220	1	2	21,50	372,36	515	345	1
1	10,00	104,55	285	185	1	2	22,00	308,09	405	270	1
1	10,00	128,91	360	235	1	2	22,00	372,36	515	345	1
1	10,50	111,01	285	185	1	2	22,50	351,13	405	270	1
1	10,50	132,88	360	235	1	2	22,50	420,30	515	345	1
1	11,00	115,88	300	195	1	2	23,00	351,13	405	270	1
1	11,00	158,46	375	250	1	2	23,00	420,30	515	345	1
1	11,50	126,89	300	195	1	3	23,50	385,79	425	270	1
1	11,50	158,46	375	250	1	3	23,50	467,77	535	345	1
1	12,00	129,85	310	205	1	3	24,00	385,79	440	290	1
1	12,00	161,81	395	260	1	3	24,00	467,77	555	365	1
1	12,50	138,20	310	205	1	3	24,50	399,81	440	290	1
1	12,50	180,61	395	260	1	3	24,50	493,00	555	365	1
1	13,00	138,20	310	205	1	3	25,00	399,81	440	290	1
1	13,00	180,61	395	260	1	3	25,00	493,00	555	365	1
1	13,50	151,33	325	220	1	3	25,50	413,24	440	290	1
1	13,50	185,48	410	275	1	3	25,50	544,58	555	365	1
1	14,00	151,33	325	220	1	3	26,00	413,24	440	290	1
1	14,00	185,48	410	275	1	3	26,00	544,58	555	365	1
2	14,50	165,75	340	220	1	3	26,50	423,17	440	290	1
2	14,50	202,01	425	275	1	3	26,50	561,90	555	365	1
2	15,00	165,75	340	220	1	3	27,00	423,17	460	305	1
2	15,00	202,01	425	275	1	3	27,00	561,90	580	385	1
2	15,50	185,82	355	230	1	3	27,50	451,45	460	305	1
2	15,50	222,83	445	295	1	3	27,50	607,87	580	385	1
2	16,00	185,82	355	230	1	3	28,00	451,45	460	305	1
2	16,00	222,83	445	295	1	3	28,00	607,87	580	385	1
2	16,50	200,24	355	230	1	3	28,50	467,77	460	305	1
2	16,50	240,77	445	295	1	3	28,50	670,70	580	385	1
2	17,00	200,24	355	230	1	3	29,00	467,77	460	305	1
2	17,00	240,77	445	295	1	3	29,00	670,70	580	385	1
2	17,50	220,33	370	245	1	3	29,50	484,30	460	305	1
2	17,50	265,13	465	310	1	3	29,50	676,23	580	385	1
2	18,00	220,33	370	245	1	3	30,00	484,30	460	305	1
2	18,00	265,13	465	310	1	3	30,00	676,23	580	385	1
2	18,50	238,86	370	245	1	3	31,00	542,88	480	320	1
2	18,50	286,50	465	310	1	3	31,00	720,98	610	410	1
2	19,00	238,86	370	245	1	4	32,00	567,63	505	320	1
2	19,00	286,50	465	310	1	4	32,00	756,44	635	410	1
2	19,50	255,09	385	260	1	4	33,00	618,52	505	320	1
2	19,50	310,06	490	325	1	4	33,00	837,44	635	410	1

(continúa Ref.1126 / suite Réf.1126 / Ref.1126 cont'd)

# BROCAS CON MANGO CÓNICO FORETS À QUEUE CONIQUE / TAPER SHANK DRILL-BITS / KONISCHER SCHAFTBOHRER

(continúa Ref.1126 / suite Réf.1126 / Ref.1126 cont'd)

▶	△	∅ mm	€	L mm	l mm	📦
4		34,00	670,67	530	340	1
4		34,00	869,68	665	430	1
4		35,00	690,77	530	340	1
4		35,00	944,27	665	430	1
4		36,00	745,25	530	340	1
4		36,00	991,56	665	430	1
4		37,00	764,06	530	340	1
4		37,00	1.101,74	665	430	1
4		38,00	833,50	555	360	1
4		38,00	1.166,67	695	460	1
4		39,00	868,68	555	360	1
4		39,00	1.222,33	695	460	1

▶	△	∅ mm	€	L mm	l mm	📦
4		40,00	915,74	555	360	1
4		40,00	1.165,93	695	460	1
4		41,00	1.325,22	695	460	1
4		42,00	1.414,93	695	460	1
4		43,00	1.443,75	735	490	1
4		44,00	1.494,49	735	490	1
4		45,00	1.564,10	735	490	1
4		46,00	1.634,02	735	490	1
4		47,00	1.714,23	735	490	1
4		48,00	1.813,93	765	510	1
4		49,00	1.882,99	765	510	1
4		50,00	1.932,18	765	510	1

1139

HSS DIN 343



P				M		K			N				S		H		
<800	<1.000	<1.200	<1.400	<950	<1.200	<500	<800	<1.400	Al	Cu	Mg/Zn	Plastic	Ni	Ti	50 HRC	55 HRC	60 HRC
●				○		●	●		○	●	○						
15-35				8-14		25-30	12-16		50-60	30-60		20-25					

Vc (m/min). ● Optima / Optimun ○ Alternativa / Alternative



▶	△	∅ mm	d mm	€	L mm	l mm	📦	▶	△	∅ mm	d mm	€	L mm	l mm	📦
1		10,00	7,00	76,08	168	87	1	2		23,00	16,00	185,77	253	155	1
1		11,00	7,70	78,79	175	94	1	3		24,00	17,00	199,92	281	160	1
1		12,00	8,40	81,54	182	101	1	3		25,00	17,50	214,06	281	160	1
1		13,00	9,10	85,21	182	101	1	3		26,00	18,00	236,35	286	165	1
1		14,00	9,80	90,17	189	108	1	3		27,00	19,00	254,70	291	170	1
2		15,00	10,50	96,98	212	114	1	3		28,00	19,50	276,11	291	170	1
2		16,00	11,20	103,24	218	120	1	3		30,00	21,00	320,29	296	175	1
2		17,00	11,90	112,90	223	125	1	4		32,00	22,00	361,08	334	185	1
2		18,00	12,60	122,35	228	130	1	4		34,00	24,00	400,35	339	190	1
2		19,00	13,30	146,10	233	135	1	4		35,00	25,00	434,27	339	190	1
2		20,00	14,00	147,59	238	140	1	4		36,00	25,50	442,33	344	195	1
2		21,00	15,00	158,45	243	145	1	4		38,00	26,50	505,10	349	200	1
2		22,00	15,50	173,38	248	150	1	4		40,00	28,00	555,65	349	210	1

**1127 HSS DIN 8376**



P				M		K			N				S		H		
<800	<1.000	<1.200	<1.400	<950	<1.200	<500	<800	<1.400	Al	Cu	Mg/Zn	Plastic	Ni	Ti	50 HRC	55 HRC	60 HRC
●	●					●	●	○	●	●		○					
15-25	8-10					30-35	25-30	14-18	20-25	30-35		15-20					

Vc (m/min). ● Optima / Optimun ○ Alternativo / Alternative

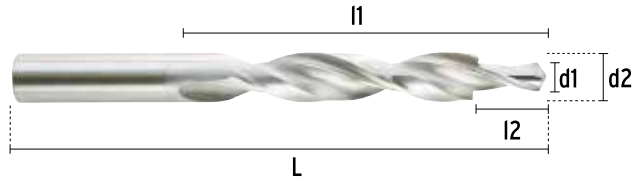

M	d1 mm	d2 mm	€	L mm	l1 mm	l2 mm	
M-3	3,40	6,00	66,45	93	57	9	1
M-4	4,50	8,00	69,67	117	75	11	1
M-5	5,50	10,00	82,83	133	87	13	1

M	d1 mm	d2 mm	€	L mm	l1 mm	l2 mm	
M-6	6,60	11,00	93,59	142	94	15	1
M-8	9,00	15,00	114,99	169	114	19	1
M-10	11,00	18,00	228,54	191	130	23	1

**1128 HSS DIN 8374**



P				M		K			N				S		H		
<800	<1.000	<1.200	<1.400	<950	<1.200	<500	<800	<1.400	Al	Cu	Mg/Zn	Plastic	Ni	Ti	50 HRC	55 HRC	60 HRC
●	●					●	●	○	●	●		○					
15-25	8-10					30-35	25-30	14-18	20-25	30-35		15-20					

Vc (m/min). ● Optima / Optimun ○ Alternativo / Alternative

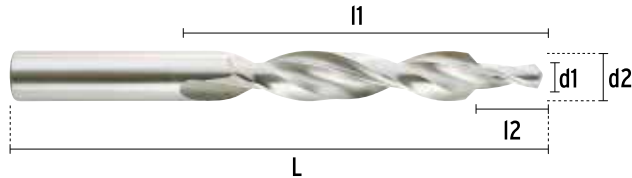

M	d1 mm	d2 mm	€	L mm	l1 mm	l2 mm	
M-3	3,20	6,00	77,54	93	57	9	1
M-4	4,30	8,00	81,30	117	75	11	1
M-5	5,30	10,00	96,65	133	87	13	1

M	d1 mm	d2 mm	€	L mm	l1 mm	l2 mm	
M-6	6,40	11,50	110,38	142	94	15	1
M-8	8,40	15,00	151,00	169	114	19	1
M-10	10,50	19,00	233,19	198	130	23	1

**1129 HSS DIN 8377**



P				M		K			N				S		H		
<800	<1.000	<1.200	<1.400	<950	<1.200	<500	<800	<1.400	Al	Cu	Mg/Zn	Plastic	Ni	Ti	50 HRC	55 HRC	60 HRC
●	●					●	●	○	●	●		○					
15-25	8-10					30-35	25-30	14-18	20-25	30-35		15-20					

Vc (m/min). ● Optima / Optimun ○ Alternativo / Alternative

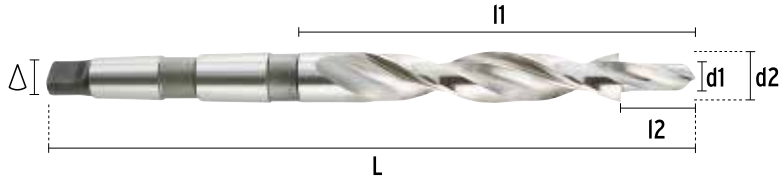

△	M	d1 mm	d2 mm	€	L mm	l1 mm	l2 mm	📦
2	M-8	9,00	15,00	172,00	212	114	19	1
2	M-10	11,00	18,00	193,86	228	130	23	1
2	M-12	14,00	20,00	216,88	238	140	27	1
3	M-14	16,00	24,00	307,56	281	160	31	1

△	M	d1 mm	d2 mm	€	L mm	l1 mm	l2 mm	📦
3	M-16	18,00	26,00	438,53	286	165	35	1
3	M-18	20,00	30,00	490,39	296	175	39	1
4	M-20	22,00	33,00	553,07	334	185	43	1

**1130 HSS DIN 8375**



P				M		K			N				S		H		
<800	<1.000	<1.200	<1.400	<950	<1.200	<500	<800	<1.400	Al	Cu	Mg/Zn	Plastic	Ni	Ti	50 HRC	55 HRC	60 HRC
●	●					●	●	○	●	●		○					
15-25	8-10					30-35	25-30	14-18	20-25	30-35		15-20					

Vc (m/min). ● Optima / Optimun ○ Alternativo / Alternative

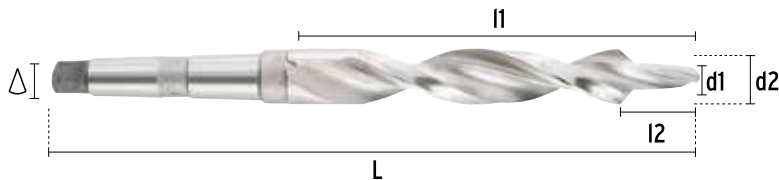

△	M	d1 mm	d2 mm	€	L mm	l1 mm	l2 mm	📦
1	M-5	5,50	11,00	166,35	175	94	13	1
1	M-6	6,60	13,00	169,74	182	101	15	1

△	M	d1 mm	d2 mm	€	L mm	l1 mm	l2 mm	📦
2	M-8	9,00	17,20	202,27	228	130	19	1
2	M-10	11,00	21,50	239,48	248	150	23	1

**1152 HSS DIN 8378**



P				M		K			N				S		H		
<800	<1.000	<1.200	<1.400	<950	<1.200	<500	<800	<1.400	Al	Cu	Mg/Zn	Plastic	Ni	Ti	50 HRC	55 HRC	60 HRC
●	●					●	●	○	●	●		○					
15-25	8-10					30-35	25-30	14-18	20-25	30-35		15-20					

Vc (m/min). ● Optima / Optimun ○ Alternativo / Alternative

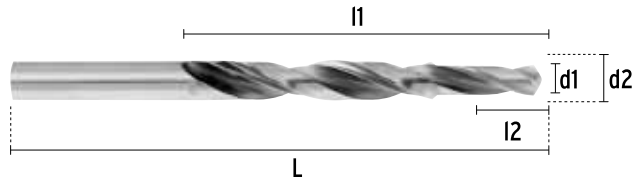

M	d1 mm	d2 mm	€	L mm	l1 mm	l2 mm	
M-3	2,50	3,40	59,56	70	39	8,80	1
M-4	3,30	4,50	64,07	80	47	11,40	1
M-5	4,20	5,50	69,01	93	57	13,60	1
M-6	5,00	6,60	78,50	101	63	16,50	1

M	d1 mm	d2 mm	€	L mm	l1 mm	l2 mm	
M-8	6,80	9,00	93,52	125	81	21,00	1
M-10	8,50	11,00	109,11	142	94	25,50	1
M-12	10,20	13,50	135,85	160	108	30,00	1

**1153 HSS DIN 8379**



P				M		K			N				S		H		
<800	<1.000	<1.200	<1.400	<950	<1.200	<500	<800	<1.400	Al	Cu	Mg/Zn	Plastic	Ni	Ti	50 HRC	55 HRC	60 HRC
●	●					●	●	○	●	●		○					
15-25	8-10					30-35	25-30	14-18	20-25	30-35		15-20					

Vc (m/min). ● Optima / Optimun ○ Alternativo / Alternative

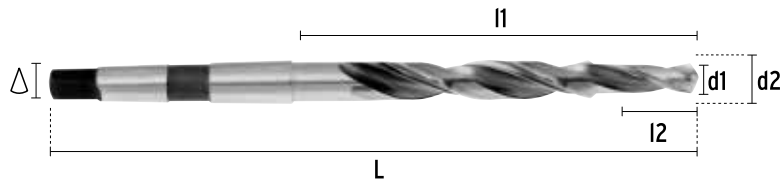

	M	d1 mm	d2 mm	€	L mm	l1 mm	l2 mm	
1	M-8	6,80	9,00	152,45	162	81	21,00	1
1	M-10	8,50	11,00	166,11	175	94	25,50	1
1	M-12	10,20	13,50	196,23	189	108	30,00	1
2	M-14	12,00	15,50	209,38	218	120	34,50	1

	M	d1 mm	d2 mm	€	L mm	l1 mm	l2 mm	
2	M-16	14,00	17,50	225,97	228	130	38,50	1
2	M-18	15,50	20,00	252,70	238	140	43,50	1
2	M-20	17,50	22,00	305,59	248	150	47,50	1



**1191 HSSCO**



P				M		K			N				S		H		
<800	<1.000	<1.200	<1.400	<950	<1.200	<500	<800	<1.400	Al	Cu	Mg/Zn	Plastic	Ni	Ti	50 HRC	55 HRC	60 HRC
●	●	○		●		●	○		●	●	●	●	○	●			
20-30	12-18	4-8		4-10		20-25	10-15		15-80	25-60	60-90	12-70	2-6	2-10			

Vc (m/min). ● Optima / Optimun ○ Alternativo / Alternative

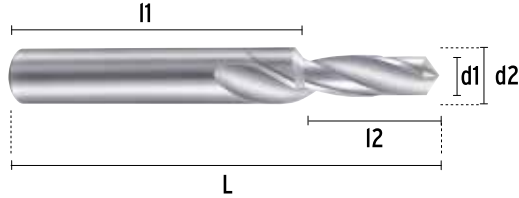

M	d1 mm	d2 mm	€	L mm	l1 mm	l2 mm	
M-3	2,50	3,40	39,70	52	20	8	1
M-4	3,30	4,50	42,00	58	24	11	1
M-5	4,20	5,50	43,85	66	28	13	1
M-6	5,00	6,60	48,00	70	31	16	1

M	d1 mm	d2 mm	€	L mm	l1 mm	l2 mm	
M-8	6,80	9,00	64,61	84	40	20	1
M-10	8,50	11,00	86,76	95	47	24	1
M-12	10,20	14,00	118,16	107	54	29	1

**1192 HSSCO**



P				M		K			N				S		H		
<800	<1.000	<1.200	<1.400	<950	<1.200	<500	<800	<1.400	Al	Cu	Mg/Zn	Plastic	Ni	Ti	50 HRC	55 HRC	60 HRC
●	●	○		●		●	○		●	●	●	●	○	●			
20-30	12-18	4-8		4-10		20-25	10-15		15-80	25-60	60-90	12-70	2-6	2-10			

Vc (m/min). ● Optima / Optimun ○ Alternativo / Alternative

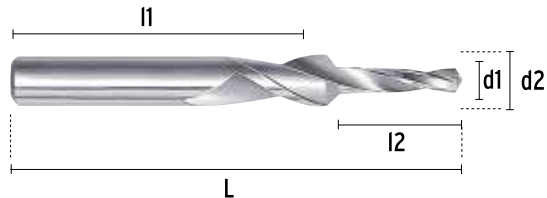

M	d1 mm	d2 mm	€	L mm	l2 mm	
M-4	4,30	8,60	105,23	110	30	1
M-5	5,30	10,40	110,77	110	30	1
M-6	6,40	12,40	118,16	110	30	1

M	d1 mm	d2 mm	€	L mm	l2 mm	
M-8	8,40	16,40	156,91	110	30	1
M-10	10,50	20,40	190,14	110	30	1

**1132 HSS DIN 333 A**

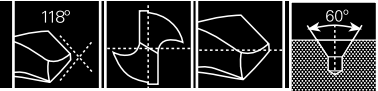

P				M		K			N				S		H		
<800	<1.000	<1.200	<1.400	<950	<1.200	<500	<800	<1.400	Al	Cu	Mg/Zn	Plastic	Ni	Ti	50 HRC	55 HRC	60 HRC
●	●					●	○		●	●		○					
20-30	8-12					20-25	15-20		15-20	25-30		10-15					

Vc (m/min). ● Optima / Optimun ○ Alternativo / Alternative



d1 mm	d2 mm	€	L mm	l mm	
1,00	3,15	6,43	31,50	1,60	1
1,25	3,15	6,43	33,50	1,90	1
1,25	4,00	7,10	35,50	1,90	1
1,60	4,00	6,43	37,50	2,40	1
1,60	5,00	7,57	40,00	2,40	1
2,00	5,00	6,93	42,00	2,90	1
2,00	6,30	8,05	45,00	2,90	1
2,50	6,30	7,70	47,00	3,60	1
2,50	8,00	9,00	50,00	3,60	1
3,15	8,00	8,48	52,00	4,40	1

d1 mm	d2 mm	€	L mm	l mm	
3,15	10,00	9,96	56,00	4,40	1
4,00	10,00	11,56	59,00	5,60	1
4,00	12,50	13,65	63,00	5,60	1
5,00	12,50	19,38	66,00	6,90	1
5,00	16,00	32,99	71,00	6,90	1
6,30	16,00	27,68	74,00	8,60	1
6,30	20,00	42,58	80,00	8,60	1
10,00	25,00	83,45	100,00	31,50	1
12,50	31,50	199,14	125,00	33,50	1

**1188 HSS DIN 333 A**

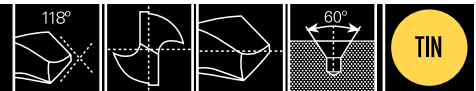

P				M		K			N				S		H		
<800	<1.000	<1.200	<1.400	<950	<1.200	<500	<800	<1.400	Al	Cu	Mg/Zn	Plastic	Ni	Ti	50 HRC	55 HRC	60 HRC
●	●					●	○		●	●		○					
30-40	12-16					30-35	20-30		20-30	35-40		10-15					

Vc (m/min). ● Optima / Optimun ○ Alternativo / Alternative

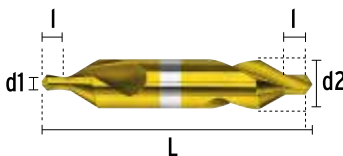

d1 mm	d2 mm	€	L mm	l mm	
1,00	3,15	12,26	31,50	1,60	1
1,25	3,15	12,26	33,50	1,90	1
1,60	4,00	12,83	37,50	2,40	1
2,00	5,00	14,05	42,00	2,90	1
2,50	6,30	15,29	47,00	3,60	1
3,15	8,00	16,01	52,00	4,40	1

d1 mm	d2 mm	€	L mm	l mm	
4,00	10,00	22,26	59,00	5,60	1
5,00	12,50	28,49	66,00	6,90	1
6,30	16,00	30,45	74,00	8,60	1
10,00	25,00	91,97	100,00	31,50	1
12,00	31,50	219,06	125,00	33,50	1

**1193** **HM-MD DIN 333 A**

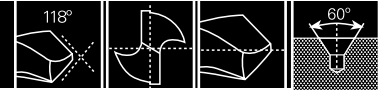

P				M		K			N				S		H		
<800	<1.000	<1.200	<1.400	<950	<1.200	<500	<800	<1.400	Al	Cu	Mg/Zn	Plastic	Ni	Ti	50 HRC	55 HRC	60 HRC
○	●	●	●	●	●	●	○	●	●	●	●	●	●	●	●	●	○
45-65	40-55	25-30	20-25	40-55	25-30	40-55	35-45	20-25	80-130	25-65	100-110	70-200	20-30	15-30	15-20	10-15	4-6

Vc (m/min). ● Optima / Optimun ○ Alternativo / Alternative



d1 mm	d2 mm	€	L mm	l mm	
1,00	3,15	59,76	31,50	1,60	1
1,25	3,15	59,76	33,50	1,90	1
1,60	4,00	61,48	37,50	2,40	1
2,00	5,00	76,84	42,00	2,90	1
2,50	6,30	91,36	47,00	3,60	1

d1 mm	d2 mm	€	L mm	l mm	
3,15	8,00	110,99	52,00	4,40	1
4,00	10,00	147,71	59,00	5,60	1
5,00	12,50	249,32	66,00	6,90	1
6,30	16,00	394,47	74,00	8,60	1

**1133** **HSS DIN 333 A**

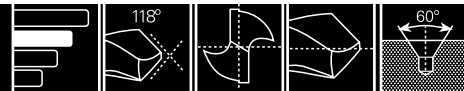

P				M		K			N				S		H		
<800	<1.000	<1.200	<1.400	<950	<1.200	<500	<800	<1.400	Al	Cu	Mg/Zn	Plastic	Ni	Ti	50 HRC	55 HRC	60 HRC
●	●					●	○		●	●		○					
20-30	8-12					20-25	15-20		15-20	25-30		10-15					

Vc (m/min). ● Optima / Optimun ○ Alternativo / Alternative



d1 mm	d2 mm	€	L mm	l mm	
1,00	4,00	20,06	60,00	1,30	1
1,50	5,00	20,42	60,00	2,00	1
2,00	6,00	21,28	80,00	2,50	1
2,50	8,00	25,85	80,00	3,10	1
3,00	8,00	25,85	80,00	3,90	1
1,00	4,00	50,05	120,00	1,30	1
1,50	5,00	47,57	120,00	2,00	1

d1 mm	d2 mm	€	L mm	l mm	
2,00	6,00	47,57	120,00	2,50	1
2,50	8,00	55,08	120,00	3,10	1
3,00	8,00	55,08	120,00	3,90	1
3,00	10,00	62,55	120,00	3,90	1
4,00	10,00	62,55	120,00	5,00	1
4,00	12,00	74,65	120,00	5,00	1
5,00	14,00	89,65	120,00	6,30	1



**1135 HSS DIN 333 R**

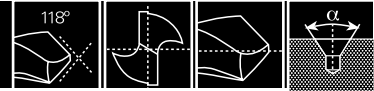

P				M		K			N				S		H		
<800	<1.000	<1.200	<1.400	<950	<1.200	<500	<800	<1.400	Al	Cu	Mg/Zn	Plastic	Ni	Ti	50 HRC	55 HRC	60 HRC
●	●					●	○		●	●		○					
20-30	8-12					20-25	15-20		15-20	25-30		10-15					

Vc (m/min). ● Optima / Optimun ○ Alternativo / Alternative



d1 mm	d2 mm	€	L mm	l mm	
1,00	3,15	7,07	31,50	3,00	1
1,25	3,15	7,07	33,50	3,35	1
1,25	4,00	7,07	35,50	3,75	1
1,60	4,00	7,07	35,50	4,25	1
1,60	5,00	7,65	40,00	4,75	1
2,00	5,00	7,65	40,00	5,30	1
2,00	6,30	8,50	45,00	6,00	1
2,50	6,30	8,48	45,00	6,70	1
2,50	8,00	9,36	50,00	7,50	1
3,15	8,00	9,36	50,00	8,50	1

d1 mm	d2 mm	€	L mm	l mm	
3,15	10,00	12,19	56,00	9,50	1
4,00	10,00	12,19	56,00	10,60	1
4,00	12,50	20,35	63,00	11,80	1
5,00	12,50	20,38	63,00	13,20	1
5,00	16,00	28,96	71,00	15,00	1
6,30	16,00	29,16	71,00	17,00	1
6,30	20,00	51,95	80,00	19,00	1
8,00	20,00	54,62	80,00	21,20	1
10,00	25,00	87,78	100,00	31,50	1
12,50	31,50	209,43	125,00	33,50	1

**1137 HSS DIN 333 B**

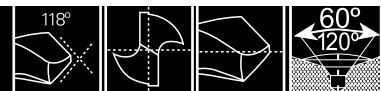

P				M		K			N				S		H		
<800	<1.000	<1.200	<1.400	<950	<1.200	<500	<800	<1.400	Al	Cu	Mg/Zn	Plastic	Ni	Ti	50 HRC	55 HRC	60 HRC
●	●					●	●		●	●		○					
20-30	8-12					20-25	15-20		15-20	25-30		10-15					

Vc (m/min). ● Optima / Optimun ○ Alternativo / Alternative



d1 mm	d2 mm	€	L mm	l mm	
1,00	4,00	11,67	35,50	1,60	1
1,25	5,00	11,67	40,00	1,90	1
1,60	6,30	11,67	45,00	2,40	1
2,00	8,00	11,67	50,00	2,90	1
2,50	10,00	13,40	56,00	3,60	1

d1 mm	d2 mm	€	L mm	l mm	
3,15	11,20	15,36	60,00	4,40	1
4,00	14,00	23,61	67,00	5,60	1
5,00	18,00	32,91	75,00	6,90	1
6,30	20,00	48,04	80,00	8,60	1

**1138 HSSCO**

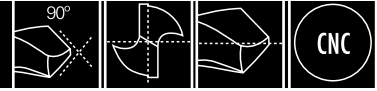

P				M		K			N				S		H		
<800	<1.000	<1.200	<1.400	<950	<1.200	<500	<800	<1.400	Al	Cu	Mg/Zn	Plastic	Ni	Ti	50 HRC	55 HRC	60 HRC
●	●	●		●		●	●		●	●		●		●			
20-30	8-12	6-10		6-12		20-25	15-20		15-20	25-30		25-30		10-12			

Vc (m/min). ● Optima / Optimun ○ Alternativo / Alternative



Ø mm	€	L mm	l mm	
3,00	23,65	50,00	10,00	1
4,00	23,65	52,00	12,00	1
5,00	26,66	60,00	15,00	1
6,00	26,66	66,00	20,00	1
8,00	30,13	79,00	25,00	1

Ø mm	€	L mm	l mm	
10,00	30,13	89,00	25,00	1
12,00	41,66	102,00	30,00	1
16,00	57,45	115,00	35,00	1
20,00	113,04	131,00	40,00	1

**1155 HSSCO**

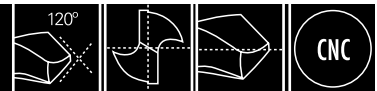

P				M		K			N				S		H		
<800	<1.000	<1.200	<1.400	<950	<1.200	<500	<800	<1.400	Al	Cu	Mg/Zn	Plastic	Ni	Ti	50 HRC	55 HRC	60 HRC
●	●	●		●		●	●		●	●		●		●			
20-30	8-12	6-10		6-12		20-25	15-20		15-20	25-30		25-30		10-12			

Vc (m/min). ● Optima / Optimun ○ Alternativo / Alternative



Ø mm	€	L mm	l mm	
3,00	23,65	46	12	1
4,00	23,65	55	12	1
5,00	26,66	62	14	1
6,00	26,66	66	16	1
8,00	30,13	79	21	1

Ø mm	€	L mm	l mm	
10,00	30,13	89	25	1
12,00	41,66	102	30	1
16,00	57,45	115	38	1
20,00	113,04	131	45	1

**1189**

**HSSCO**

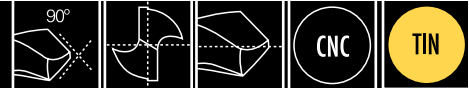

P				M		K			N				S		H		
<800	<1.000	<1.200	<1.400	<950	<1.200	<500	<800	<1.400	Al	Cu	Mg/Zn	Plastic	Ni	Ti	50 HRC	55 HRC	60 HRC
●	●	●		●		●	●		●	●		●		●			
20-30	12-16	10-14		6-12		30-35	20-25		20-25	35-40		35-40		12-16			

Vc (m/min). ● Optima / Optimun ○ Alternativo / Alternative

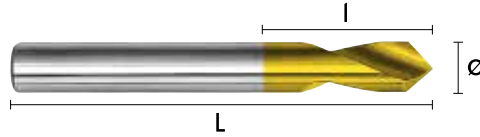

Ø mm	€	L mm	l mm	
3,00	30,74	50	10	1
4,00	30,74	52	12	1
5,00	34,66	60	15	1
6,00	34,66	66	20	1
8,00	39,17	79	25	1

Ø mm	€	L mm	l mm	
10,00	39,17	89	25	1
12,00	54,16	102	30	1
16,00	74,69	115	35	1
20,00	146,95	131	40	1

**1190**

**HSSCO**



P				M		K			N				S		H		
<800	<1.000	<1.200	<1.400	<950	<1.200	<500	<800	<1.400	Al	Cu	Mg/Zn	Plastic	Ni	Ti	50 HRC	55 HRC	60 HRC
●	●	●		●		●	●		●	●		●		●			
20-30	12-16	10-14		6-12		30-35	20-25		20-25	35-40		35-40		12-16			

Vc (m/min). ● Optima / Optimun ○ Alternativo / Alternative

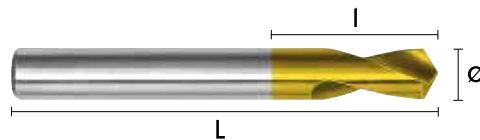

Ø mm	€	L mm	l mm	
3,00	30,74	46	12	1
4,00	30,74	55	12	1
5,00	34,66	62	14	1
6,00	34,66	66	16	1
8,00	39,17	79	21	1

Ø mm	€	L mm	l mm	
10,00	39,17	89	25	1
12,00	54,16	102	30	1
16,00	74,69	115	38	1
20,00	146,95	131	45	1

1179

**HM-MD**

1XD



P				M		K			N				S		H		
<800	<1.000	<1.200	<1.400	<950	<1.200	<500	<800	<1.400	Al	Cu	Mg/Zn	Plastic	Ni	Ti	50 HRC	55 HRC	60 HRC
●	●	●		●		●	●		●	●		○	○	●			
55-80	40-55	35-45		15-30		60-80	40-60		70-160	60-120		50-70	8-20	20-30			

Vc (m/min). ● Optima / Optimun ○ Alternativo / Alternative



∅ mm	d mm	€	L mm	l mm	
6,00	6	26,11	65	15	1
8,00	8	44,97	80	20	1

∅ mm	d mm	€	L mm	l mm	
10,00	10	64,84	90	25	1
12,00	12	90,98	100	30	1

1180

**HM-MD**

1XD



P				M		K			N				S		H		
<800	<1.000	<1.200	<1.400	<950	<1.200	<500	<800	<1.400	Al	Cu	Mg/Zn	Plastic	Ni	Ti	50 HRC	55 HRC	60 HRC
●	●	●		●		●	●		●	●		○	○	●			
55-80	40-55	35-45		15-30		60-80	40-60		70-160	60-120		50-70	8-20	20-30			

Vc (m/min). ● Optima / Optimun ○ Alternativo / Alternative



∅ mm	d mm	€	L mm	l mm	
6,00	6	26,11	65	15	1
8,00	8	44,97	80	20	1

∅ mm	d mm	€	L mm	l mm	
10,00	10	64,84	90	25	1
12,00	12	90,98	100	30	1

**1185**

**HM-MD**

**1XD**



P				M		K			N				S		H		
<800	<1.000	<1.200	<1.400	<950	<1.200	<500	<800	<1.400	Al	Cu	Mg/Zn	Plastic	Ni	Ti	50 HRC	55 HRC	60 HRC
●	●	●		●		●	●		●	●		○	○	●			
70-100	55-75	50-60		20-35		80-100	55-80		100-200	80-160		50-70	12-20	25-35			

Vc (m/min). ● Optima / Optimun ○ Alternativo / Alternative

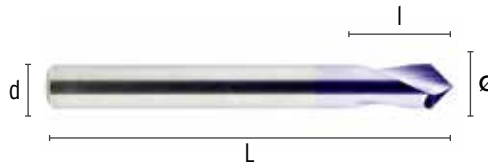

∅ mm	d mm	€	L mm	l mm	
6,00	6	33,94	65	15	1
8,00	8	58,46	80	20	1

∅ mm	d mm	€	L mm	l mm	
10,00	10	84,29	90	25	1
12,00	12	118,27	100	30	1

**1186**

**HM-MD**

**1XD**



P				M		K			N				S		H		
<800	<1.000	<1.200	<1.400	<950	<1.200	<500	<800	<1.400	Al	Cu	Mg/Zn	Plastic	Ni	Ti	50 HRC	55 HRC	60 HRC
●	●	●		●		●	●		●	●		○	○	●			
70-100	55-75	50-60		20-35		80-100	55-80		100-200	80-160		50-70	12-20	25-35			

Vc (m/min). ● Optima / Optimun ○ Alternativo / Alternative

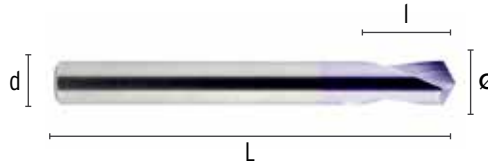

∅ mm	d mm	€	L mm	l mm	
6,00	6	33,94	65	15	1
8,00	8	58,46	80	20	1

∅ mm	d mm	€	L mm	l mm	
10,00	10	84,29	90	25	1
12,00	12	118,27	100	30	1



**1119**

**HSSCO DIN 1897 N Soldadura / Soudure / Welding**



P				M		K			N				S		H		
<800	<1.000	<1.200	<1.400	<950	<1.200	<500	<800	<1.400	Al	Cu	Mg/Zn	Plastic	Ni	Ti	50 HRC	55 HRC	60 HRC
○ 20-30	● 12-18	● 6-10															

Vc (m/min). ● Optima / Optimun ○ Alternativo / Alternative

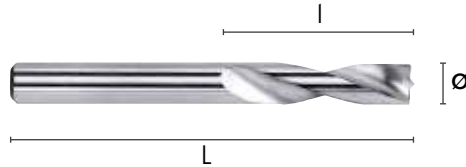

Ø mm	€	L mm	l mm	
6,00	13,62	66	28	1
7,00	15,01	74	34	1

Ø mm	€	L mm	l mm	
8,00	16,45	79	37	1
10,00	18,61	89	43	1

**1194**

**HSSCO DIN 1897N Soldadura / Soudure / Welding**



P				M		K			N				S		H		
<800	<1.000	<1.200	<1.400	<950	<1.200	<500	<800	<1.400	Al	Cu	Mg/Zn	Plastic	Ni	Ti	50 HRC	55 HRC	60 HRC
○ 30-40	● 16-20	● 8-14															

Vc (m/min). ● Optima / Optimun ○ Alternativo / Alternative

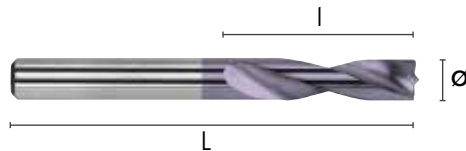

Ø mm	€	L mm	l mm	
6,00	23,84	66	28	1
7,00	26,28	74	34	1

Ø mm	€	L mm	l mm	
8,00	28,79	79	37	1
10,00	32,56	89	43	1



**5114 HSS**

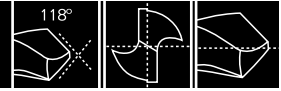

P				M		K			N				S		H		
<800	<1.000	<1.200	<1.400	<950	<1.200	<500	<800	<1.400	Al	Cu	Mg/Zn	Plastic	Ni	Ti	50 HRC	55 HRC	60 HRC
●									●	●		●					
10-25									15-20	25-30		25-30					

Vc (m/min). ● Optima / Optimun ○ Alternativo / Alternative

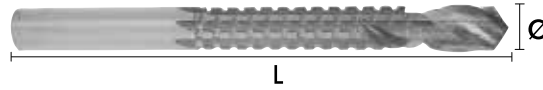

Ø mm	€	L mm	Z	
6,00	17,71	90	5	1
8,00	24,21	90	7	1

**5115 HSS**



P				M		K			N				S		H		
<800	<1.000	<1.200	<1.400	<950	<1.200	<500	<800	<1.400	Al	Cu	Mg/Zn	Plastic	Ni	Ti	50 HRC	55 HRC	60 HRC
●									●	●		●					
15-35									20-25	35-40		35-40					

Vc (m/min). ● Optima / Optimun ○ Alternativo / Alternative

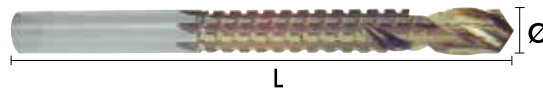

Ø mm	€	L mm	Z	
6,00	32,14	90	5	1
8,00	42,02	90	7	1

**6110** Espiga / Queue à tenon / Bit shank / Stift



»	△	DIN 228	€	L mm	gr	☐
	1	B-12	10,48	89	65	1
	1	B-16	10,48	99	80	1
	1	B-18	10,48	107	110	1
	>2	B-12	12,70	106	140	1
	2	B-16	12,70	112	160	1
	2	B-18	12,70	119	185	1

»	△	DIN 228	€	L mm	gr	☐
	>3	B-16	15,50	134	305	1
	3	B-18	15,50	140	330	1
	>4	B-16	22,20	156	120	1
	4	B-18	23,93	165	640	1
	>5	B-16	94,51	221	1.570	1
	5	B-18	94,51	221	1.590	1

**6111** Casquillo DIN 2185 / Douille de réduction / Drill sleeve / Bohrerhülse DIN 2185



»	△	€	L mm	gr	☐
	2 x 1	25,56	92	90	1
	3 x 1	31,56	99	200	1
	3 x 2	31,56	112	180	1
	4 x 1	44,14	124	510	1
	4 x 2	41,49	124	420	1
	4 x 3	41,49	140	370	1
	5 x 1	73,20	180	1.550	1

»	△	€	L mm	gr	☐
	5 x 2	69,38	156	1.200	1
	5 x 3	69,38	156	1.150	1
	5 x 4	80,97	171	1.023	1
	6 x 3	134,75	230	3.800	1
	6 x 4	152,88	230	3.390	1
	6 x 5	152,88	230	2.700	1

**6114** Contrapunto / Contrepointe / Fixed centre / Reitstock



»	△	HSS €	HM €	☐
	1	15,84	-	1
	2	21,09	-	1
	3	32,76	79,16	1

»	△	HSS €	HM €	☐
	4	51,21	96,52	1
	5	72,32	188,70	1
	6	278,89	-	1

**6112** **Alargadera / Adaptateur / Extension piece / Verlängerungsstück**



Ext.	Int.	€	L mm	Box
1	1	32,21	145	1
1	2	49,88	160	1
2	1	32,21	160	1
2	2	46,82	175	1
2	3	67,81	196	1
3	1	46,82	175	1
3	2	48,35	194	1
3	3	70,90	215	1
3	4	114,36	240	1
4	1	67,81	200	1

Ext.	Int.	€	L mm	Box
4	2	66,27	215	1
4	3	69,36	240	1
4	4	114,36	265	1
4	5	191,94	300	1
5	1	130,73	232	1
5	2	121,55	247	1
5	3	128,36	268	1
5	4	145,09	300	1
5	5	240,05	335	1

**6113** **Expulsor / Éjecteur / Ejector / Auswerfer**



Ext.	€	gr	Box
1 - 2	13,65	50	1
2 - 3	16,15	80	1
3 - 4	21,31	160	1

Ext.	€	gr	Box
4 - 5	28,95	350	1
5 - 6	47,05	690	1

**6115** **Punto giratorio / Pointe tournante / Revolving lathe centre / Mitlaufende Drehbankspitze**

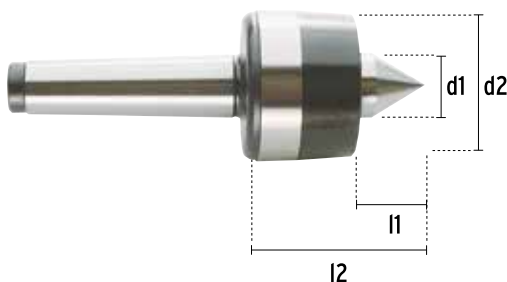

Ext.	d1 mm	d2 mm	l1 mm	l2 mm	Kg	€	Box
1	12	32	18	42	180	151,85	1
2	16	40	23	46	400	169,38	1
3	24	45	27	53	600	227,70	1
4	24	59	36	65	1200	269,85	1
5	38	79	41	77	1500	390,02	1

**6101 HP1**

- > **Componentes totalmente templados y rectificados.**  
Composants entièrement trempés et rectifiés.  
Fully tempered and rectified components.
- > **Uso en taladros de precisión estacionarios, fresadoras.**  
Pour perçages de précision stationnaires, fraiseuses.  
For use with stationary precision drills, milling machines.
- > **Excentricidad máxima 0,04 mm.**  
Excentricité maximum de 0,04 mm.  
Maximum eccentricity 0.04 mm.

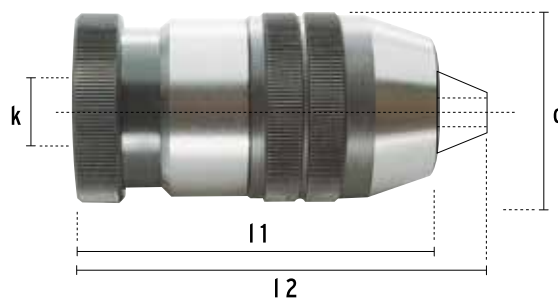

Ø mm	d mm		k Int.	€	l1 mm	l2 mm		Husillo Arbre Spindle €	Juego de garras Jeux de griffes Set of claws €
0,00 - 10,00	41	B16	1/2" - 20H*	182,04	81	89	1	31,14	42,24
1,00 - 13,00	46	B16	1/2" - 20H*	199,87	88	89	1	33,44	45,33

\*(Hasta fin de existencias / Jusqu'à épuisement des stocks / While supplies last)

**6120 HP1-CM**

- > **Portabrocas automático alta precisión con espiga integrada (Cono Morse)**  
Mandrin automatique de haute précision avec queue à tenon intégrée (Cone Morse)  
High precision automatic drill chuck with bit shank (Taper Shank)

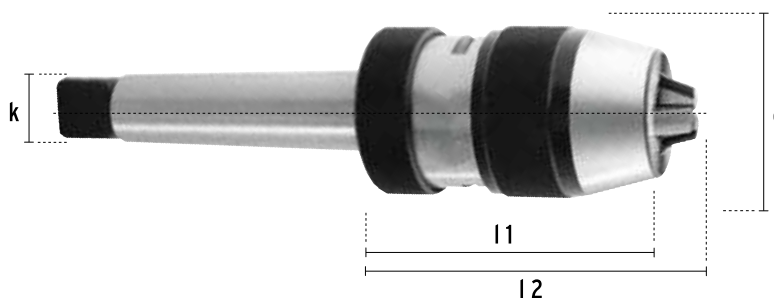

Ø mm	d mm	k 	€	l1 mm	l2 mm		Husillo Arbre Spindle €	Juego de garras Jeux de griffes Set of claws €
0,00 - 10,00	43	CM2	394,53	73	82	1	31,14	42,24
1,00 - 13,00	48	CM2, CM3, CM4	428,35	80	92	1	33,44	45,33
3,00 - 16,00	54	CM2, CM3, CM4	511,72	85	96	1	33,44	46,84



**6102** > **HP2**

- > **Componentes parcialmente templados y rectificados.**  
Composants partiellement trempés et rectifiés.  
Partially tempered and rectified components.
- > **Uso industrial para taladros fijos y portátiles.**  
Usage industriel pour perceuses fixes et portables.  
For industrial use with fixed and portable drills.
- > **Excentricidad máxima 0,20 mm.**  
Excentricité maximum de 0,20 mm.  
Maximum eccentricity 0.20 mm.

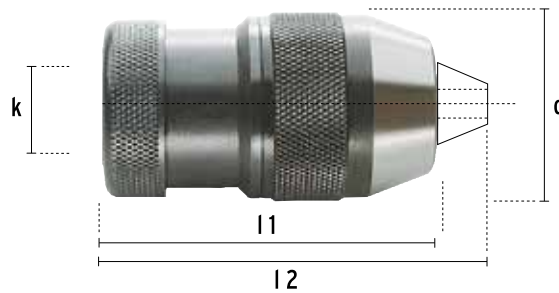

∅ mm	d mm		k Int.	€	l1 mm	l2 mm		Husillo Arbre Spindle €	Juego de garras Jeu de griffes Set of claws €
0,00 - 10,00	39	B12	1/2" - 20H 3/8" - 24H	99,70	73	80	1	21,04	42,04
2,00 - 13,00	46	B16	1/2" - 20H 3/8" - 24H	125,31	87	95	1	24,27	45,43
3,00 - 16,00	51	B16,B18	5/8" - 16H 1/2" - 20H	166,46	102	115	1	24,27	45,43
5,00 - 20,00	56	B18	-	219,45	95	110	1	29,72	53,43

**6103** > **HP3**

- > **Uso industrial para taladros fijos y portátiles.**  
Usage industriel pour perceuses fixes et portables.  
For industrial use with fixed and portable drills.
- > **Excentricidad no garantizada.**  
Excentricité non garantie.  
Maximum not guaranteed.



∅ mm	d mm		k Int.	€	l1 mm	l2 mm	
1,00 - 10,00	35	B12*	1/2" - 20H, 3/8" - 24H*	67,07	65	72	1
1,50 - 13,00	40	B16	1/2" - 20H	76,96	83	91	1
3,00 - 16,00	53	B16,B18	1/2" - 20H, 5/8" - 24H*	101,64	96	109	1

\* (Hasta fin de existencias / Jusqu'à épuisement des stocks / While supplies last)

**6122** > **Afilador de Brocas / Affûteuses forets / Twist Drill Sharpener / Bohrschärfer**

- > **Para Brocas HSS, HSSE, HSS+TIN, HM**  
 Pour Forets HSS, HSSE, HSS+TIN, HM  
 For Drill-bits HSS, HSSE, HS+TIN, HM
- > **Para ángulo normal afilado en cruz**  
 Pour angle normal et affûtage en croix  
 For normal angle and Splint point
- > **Ángulo de punta de 118°**  
 Angle de la point e 118°  
 Point angle of 118°



∅ mm	€	
3 a 13	168,90	1

**6123** > **Porta / Mandrins / Chuck / Bohrfutter**

€	
10,23	1



**6124** > **Muela / Meule / Wheel / Schleifscheibe**

€	
21,71	1



**1171** **Ø 1 a 10 X 0,5 mm**

Ø mm 1 a 10	X mm 0,50	 19	DIN <b>338</b>
-------------------	-----------------	---	-------------------

>HSS  
(1101)



>SPEED PLUS  
(1158)



>HSS CO  
(1105)



>HSS CO INOX  
(1106)



>HSS TIN  
(1108)



REF.	€
HSS	49,64
SPEED PLUS	54,43
HSS CO	81,79
HSS CO INOX	167,88
HSS TIN	101,45
VACÍO/VIDE/EMPTY	13,14

**1172** **Ø 1 a 13 X 0,5 mm**

Ø mm 1 a 13	X mm 0,50	 25	DIN <b>338</b>
-------------------	-----------------	---	-------------------

>HSS  
(1101)



>SPEED PLUS  
(1158)



>HSS CO  
(1105)



>HSS CO INOX  
(1106)



>HSS TIN  
(1108)



REF.	€
HSS	97,12
SPEED PLUS	106,85
HSS CO	187,28
HSS CO INOX	337,54
HSS TIN	211,05
VACÍO/VIDE/EMPTY	17,53

**1143** **Ø 1 a 10 X 0,25 mm**

Ø mm 1 a 10	X mm 0,25	 37	DIN <b>338</b>
-------------------	-----------------	---	-------------------

>HSS  
(1101)



>HSS CO  
(1105)



REF.	€
HSS	136,48
HSS CO	201,45
VACÍO/VIDE/EMPTY	44,42



**1144** **Ø 6 a 10 X 0,10 mm**

Ø mm 6 a 10	X mm 0,10	 41	DIN <b>338</b>
-------------------	-----------------	---	-------------------

>HSS  
(1101)



>HSS CO  
(1105)



REF.	€
HSS	256,50
HSS CO	367,25
VACÍO/VIDE/EMPTY	76,88

**1145** **Ø 1 a 13 X 0,25 mm**

Ø mm 1 a 13	X mm 0,25	 49	DIN <b>338</b>
-------------------	-----------------	---	-------------------

>HSS  
(1101)



>HSS CO  
(1105)



REF.	€
HSS	237,51
HSS CO	440,55
VACÍO/VIDE/EMPTY	46,13

**1146** **Ø 1 a 6 X 0,10 mm**

Ø mm 1 a 6	X mm 0,10	 51	DIN <b>338</b>
------------------	-----------------	---	-------------------

>HSS  
(1101)



>HSS CO  
(1105)



REF.	€
HSS	104,26
HSS CO	148,04
VACÍO/VIDE/EMPTY	30,75

**1173** **1/16" a 3/8" X 1/64"**  **DIN 338**

>HSS  
 (1158/9)



>HSS CO  
 (1105/9)



REF.	€
SPEED PLUS	79,45
HSS CO	109,31

**1174** **1/16" a 1/2" X 1/64"**  **DIN 338**

>SPEED PLUS  
 (1158/9)



>HSS CO  
 (1105/9)



REF.	€
SPEED PLUS	144,34
HSS CO	241,03

**JUEGO DE BROCAS**  
**COFFRETS DE FORETS / DRILL SETS / BOHRSATZ**

**1150** **Ø 1 a 10 X 0,5 mm**

Ø  
mm  
1 a 10

X  
mm  
0,50

DIN  
**338**

>HSS  
(1101)

>HSS NSP  
(1158)

>HSS CO  
(1105)

>HSS TIN  
(1108)



REF.	€
HSS	574,66
HSS NSP	616,68
HSS CO	502,31
HSS TIN	641,25
VACÍO/VIDE/EMPTY	76,88

Ø mm	HSS	HSS NSP	HSS CO	HSS TIN
1,00	20	20	10	10
1,50	10	10	5	5
2,00	20	20	10	10
2,50	10	10	5	5
3,00	20	20	10	10
3,50	10	10	5	5
4,00	20	20	10	10
4,50	10	10	5	5
5,00	20	20	10	10
5,50	10	10	5	5

Ø mm	HSS	HSS NSP	HSS CO	HSS TIN
6,00	20	20	10	10
6,50	10	10	5	5
7,00	10	10	5	5
7,50	10	10	5	5
8,00	10	10	5	5
8,50	10	10	5	5
9,00	10	10	5	5
9,50	10	10	5	5
10,00	10	10	5	5
TOTAL	250	250	125	125

**1183** **Ø 1 a 13 X 0,5 mm**

Ø  
mm  
1 a 10

X  
mm  
0,50

DIN  
**338**

>HSS  
(1101)

>HSS NSP  
(1158)

>HSS CO  
(1105)

>HSS TIN  
(1108)



REF.	€
HSS	888,30
HSS NSP	955,05
HSS CO	1.105,97
HSS TIN	1.265,46
VACÍO/VIDE/EMPTY	153,77

Ø mm	HSS	HSS NSP	HSS CO	HSS TIN
1,00	20	20	10	10
1,50	10	10	5	5
2,00	20	20	10	10
2,50	10	10	5	5
3,00	20	20	10	10
3,50	10	10	5	5
4,00	20	20	10	10
4,50	10	10	5	5
5,00	20	20	10	10
5,50	10	10	5	5
6,00	20	20	10	10
6,50	10	10	5	5
7,00	10	10	5	5

Ø mm	HSS	HSS NSP	HSS CO	HSS TIN
7,50	10	10	5	5
8,00	10	10	5	5
8,50	10	10	5	5
9,00	10	10	5	5
9,50	10	10	5	5
10,00	10	10	5	5
10,50	5	5	5	5
11,00	5	5	5	5
11,50	5	5	5	5
12,00	5	5	5	5
12,50	5	5	5	5
13,00	5	5	5	5
TOTAL	280	280	155	155



**8201** > Ø 1 a 13 mm

>HSS DIN 338 N  
(1101)





>HSS DIN 338 NSP  
(1158)

>HSSCO DIN 338 N  
(1105)

>HSSCO DIN 338 W  
(1106)

>HSSTIN DIN 338 N  
(1108)



Ø mm	 HSS DIN 338 N					 HSS DIN 338 NSP					 HSSCO DIN 338 N					 HSSCO DIN 338 W					 HSSTIN DIN 338 N				
	HSS DIN 338 N	HSS DIN 338 NSP	HSSCO DIN 338 N	HSSCO DIN 338 W	HSSTIN DIN 338 N	HSS DIN 338 N	HSS DIN 338 NSP	HSSCO DIN 338 N	HSSCO DIN 338 W	HSSTIN DIN 338 N	HSS DIN 338 N	HSS DIN 338 NSP	HSSCO DIN 338 N	HSSCO DIN 338 W	HSSTIN DIN 338 N										
1,00	20	20	20	-	20	20	20	10	-	10	20	20	10	10	10										
1,50	20	20	10	-	10	20	20	10	-	10	20	20	10	10	10										
2,00	50	50	20	-	20	10	10	10	-	10	20	20	10	10	10										
2,25	20	20	20	-	10	20	20	20	-	10	20	20	10	10	10										
2,50	40	40	20	-	10	20	20	10	-	10	20	20	10	10	10										
3,00	50	50	20	-	20	20	20	10	-	20	20	20	10	10	10										
3,25	30	30	20	10	10	20	20	10	10	10	20	20	10	10	10										
3,50	40	40	20	10	20	20	20	10	10	20	20	20	10	10	10										
4,00	50	50	30	10	30	20	20	10	10	30	20	20	10	10	10										
4,25	30	30	20	10	10	20	20	10	10	10	20	20	10	10	10										
4,50	40	40	20	10	10	20	20	10	10	10	20	20	10	10	10										
5,00	50	50	30	10	30	20	20	10	10	30	20	20	10	10	10										
5,25	20	20	10	10	10	20	20	10	10	10	20	20	10	10	10										
5,50	30	30	20	10	20	20	20	10	10	20	20	20	10	10	10										
6,00	50	50	30	10	20	20	20	10	10	20	20	20	10	10	10										
<b>TOTAL</b>						<b>735</b>	<b>735</b>	<b>430</b>	<b>200</b>	<b>360</b>															
<b>€</b>						<b>1.518,25</b>	<b>1.659,54</b>	<b>1.804,40</b>	<b>2.359,90</b>	<b>1.903,28</b>															

**8201/9** **1/16" a 1/2" x 1/64"**

>HSS DIN 338 NSP  
 (1158/9)



>HSSCO DIN 338 N  
 (1105/9)

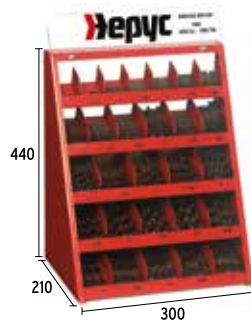

Ø mm	HSS DIN 338 NSP	HSSCO DIN 338 N
1/16"	20	20
5/64"	20	10
3/32"	50	20
7/64"	20	20
1/8"	40	20
9/64"	50	20
5/32"	30	20
11/64"	40	20
3/16"	50	30
13/64"	30	20
7/32"	40	20
15/64"	50	30
1/4"	20	10
17/64"	30	20
9/32"	50	30

Ø mm	HSS DIN 338 NSP	HSSCO DIN 338 N
19/64"	20	10
5/16"	20	10
21/64"	10	10
11/32"	40	20
23/64"	20	10
3/8"	20	10
25/64"	10	10
13/32"	20	10
27/64"	5	5
7/16"	5	5
29/64"	5	5
15/32"	10	5
31/64"	5	5
1/2"	5	5
TOTAL	735	430
€	1.966,95	2.111,26



**8203** > Ø 14 a 30 mm (Ref. 1121)

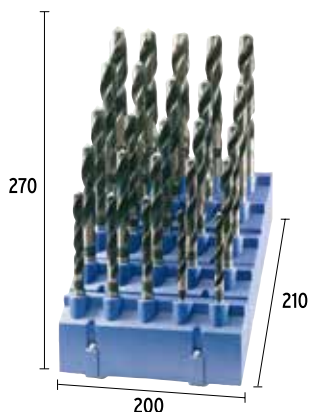

Ø mm	Icon	Ø mm	Icon	Ø mm	Icon
14,00	1	18,50	1	23,00	1
14,50	1	19,00	1	24,00	1
15,00	1	19,50	1	25,00	1
15,50	1	20,00	1	26,00	1
16,00	1	20,50	1	27,00	1
16,50	1	21,00	1	28,00	1
17,00	1	21,50	1	30,00	1
17,50	1	22,00	1		
18,00	1	22,50	1		
				<b>TOTAL</b>	<b>25</b>
				€	1374,16

**8207** > Ø 1 a 16 mm

>HSS DIN 338 N  
(1101)

>HSS DIN 338 NSP  
(1158)

>HSSCO DIN 338 N  
(1105)

>HSSCO DIN 338 W  
(1187)

>HSSTIN DIN 338 N  
(1108)

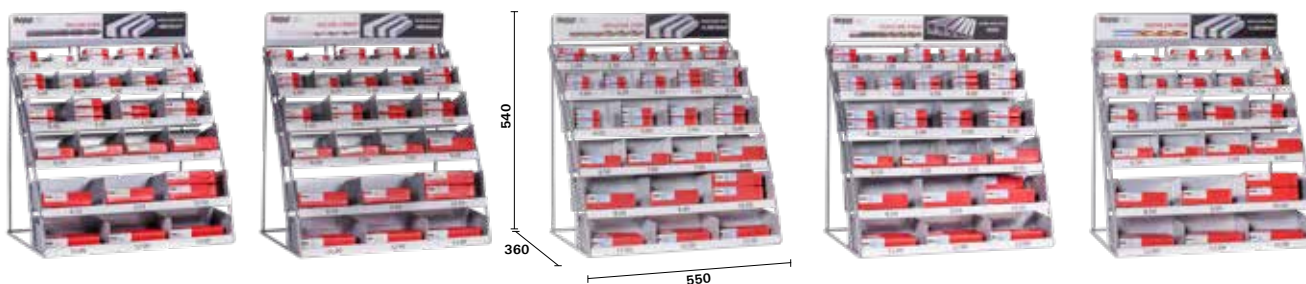

Ø mm	HSS DIN 338 N	HSS DIN 338 NSP	HSSCO DIN 338 N	HSSCO DIN 338 W	HSSTIN DIN 338 N
1,00	40	40	40	40	40
1,50	20	20	20	20	20
2,00	40	40	40	40	40
2,25	40	40	40	40	40
2,50	40	40	40	40	40
3,00	60	60	60	60	60
3,25	40	40	40	40	40
3,50	40	40	40	40	40
4,00	60	60	60	60	60
4,25	40	40	40	40	40
4,50	40	40	40	40	40
5,00	60	60	60	60	60
5,50	40	40	40	40	40
6,00	60	60	60	60	60

Ø mm	HSS DIN 338 N	HSS DIN 338 NSP	HSSCO DIN 338 N	HSSCO DIN 338 W	HSSTIN DIN 338 N
6,50	20	20	20	20	20
7,00	20	20	20	20	20
7,50	20	20	20	20	20
8,00	30	30	30	30	30
8,50	20	20	20	20	20
9,00	20	20	20	20	20
10,00	20	20	20	20	20
11,00	10	10	10	10	10
12,00	10	10	10	10	10
13,00	5	5	5	5	5
<b>TOTAL</b>	<b>795</b>	<b>795</b>	<b>795</b>	<b>795</b>	<b>795</b>
€	1.469,27	1.619,36	2.704,59	4.153,98	3.334,23